

# SECTION **DAS**

## DRIVER ASSISTANCE SYSTEM

A  
B  
C

### CONTENTS

D

E

<b>ADAS CONTROL UNIT</b>		
<b>PRECAUTION</b> .....	7	
<b>PRECAUTIONS</b> .....	7	
Precaution for Supplemental Restraint System (SRS) "AIR BAG" and "SEAT BELT PRE-TENSIONER" .....	7	
Precaution for Work .....	7	
Precautions For Harness Repair .....	7	
<b>SYSTEM DESCRIPTION</b> .....	9	
<b>COMPONENT PARTS</b> .....	9	
Component Parts Location .....	9	
ADAS Control Unit .....	9	
<b>SYSTEM</b> .....	10	
System Description .....	10	
Fail-safe (ADAS Control Unit) .....	12	
<b>DIAGNOSIS SYSTEM (ADAS CONTROL UNIT)</b> .....	14	
CONSULT Function (ICC/ADAS) .....	14	
<b>ECU DIAGNOSIS INFORMATION</b> .....	20	
<b>ADAS CONTROL UNIT</b> .....	20	
Reference Value .....	20	
Fail-safe (ADAS Control Unit) .....	24	
DTC Inspection Priority Chart .....	24	
DTC Index .....	25	
<b>WIRING DIAGRAM</b> .....	27	
<b>DRIVER ASSISTANCE SYSTEMS</b> .....	27	
Wiring Diagram .....	27	
<b>BASIC INSPECTION</b> .....	36	
<b>ADDITIONAL SERVICE WHEN REPLACING ADAS CONTROL UNIT</b> .....	36	
Description .....	36	
Work Procedure .....	36	
<b>CONFIGURATION (ADAS CONTROL UNIT)</b> ...	37	
Description .....	37	
Work Procedure .....	37	
<b>DTC/CIRCUIT DIAGNOSIS</b> .....	39	
<b>C1A00 CONTROL UNIT</b> .....	39	
DTC Description .....	39	
Diagnosis Procedure .....	39	
<b>C1A01 POWER SUPPLY CIRCUIT 1, C1A02 POWER SUPPLY CIRCUIT 2</b> .....	40	
DTC Description .....	40	
Diagnosis Procedure .....	40	
<b>C1A03 VEHICLE SPEED SENSOR</b> .....	41	
DTC Description .....	41	
Diagnosis Procedure .....	41	
<b>C1A13 STOP LAMP RELAY</b> .....	43	
DTC Description .....	43	
Diagnosis Procedure .....	44	
Component Inspection .....	48	
<b>C1A14 ECM</b> .....	49	
DTC Description .....	49	
Diagnosis Procedure .....	49	
<b>C1A17 ICC SENSOR</b> .....	51	
DTC Description .....	51	
Diagnosis Procedure .....	51	
<b>C1A34 COMMAND ERROR</b> .....	52	
DTC Description .....	52	
Diagnosis Procedure .....	52	
<b>C1B53 SIDE RADAR RIGHT MALFUNCTION</b> ...	53	
DTC Description .....	53	
Diagnosis Procedure .....	53	
<b>C1B54 SIDE RADAR LEFT MALFUNCTION</b> ...	54	

F

G

H

I

J

K

L

M

N



P

DTC Description .....	54	<b>REMOVAL AND INSTALLATION .....</b>	<b>80</b>
Diagnosis Procedure .....	54	<b>ADAS CONTROL UNIT .....</b>	<b>80</b>
<b>U0121 VDC CAN 2 .....</b>	<b>55</b>	Removal and Installation .....	80
DTC Description .....	55	<b>DRIVER ASSISTANCE SYSTEM</b>	
Diagnosis Procedure .....	55	<b>PRECAUTION .....</b>	<b>81</b>
<b>U0235 ICC SENSOR CAN 1 .....</b>	<b>57</b>	<b>PRECAUTIONS .....</b>	<b>81</b>
DTC Description .....	57	Precaution for Supplemental Restraint System (SRS) "AIR BAG" and "SEAT BELT PRE-TENSIONER" .....	81
Diagnosis Procedure .....	57	Precaution for Work .....	81
<b>U0401 ECM CAN 1 .....</b>	<b>58</b>	Precautions For Harness Repair .....	81
DTC Description .....	58	ICC System Service .....	82
Diagnosis Procedure .....	58	FEB System Service .....	82
<b>U0402 TCM CAN 1 .....</b>	<b>60</b>	Blind Spot Warning System Service .....	82
DTC Description .....	60	<b>PREPARATION .....</b>	<b>83</b>
Diagnosis Procedure .....	60	<b>PREPARATION .....</b>	<b>83</b>
<b>U0415 VDC CAN 1 .....</b>	<b>62</b>	Special Service Tools .....	83
DTC Description .....	62	<b>SYSTEM DESCRIPTION .....</b>	<b>84</b>
Diagnosis Procedure .....	62	<b>COMPONENT PARTS .....</b>	<b>84</b>
<b>U0433 DIST SEN CAN CIRC 2 .....</b>	<b>64</b>	Component Parts Location .....	84
DTC Description .....	64	ICC Sensor .....	85
Diagnosis Procedure .....	64	ICC Steering Switch .....	85
<b>U1000 CAN COMM CIRCUIT .....</b>	<b>65</b>	Brake Pedal Position Switch / Stop Lamp Switch ...	86
Description .....	65	ICC Brake Hold Relay .....	86
DTC Description .....	65	Combination Meter .....	86
Diagnosis Procedure .....	66	Side Radar LH/RH .....	87
<b>U1321 CONFIGURATION .....</b>	<b>67</b>	Blind Spot Warning Indicator LH/RH .....	87
DTC Description .....	67	<b>SYSTEM .....</b>	<b>88</b>
Diagnosis Procedure .....	67	<b>PFCW .....</b>	<b>88</b>
<b>U1503 SIDE RDR L CAN 2 .....</b>	<b>68</b>	PFCW : System Description .....	88
DTC Description .....	68	<b>BSW .....</b>	<b>89</b>
Diagnosis Procedure .....	68	BSW : System Description .....	90
<b>U1504 SIDE RDR L CAN 1 .....</b>	<b>70</b>	<b>RCTA .....</b>	<b>92</b>
DTC Description .....	70	RCTA : System Description .....	92
Diagnosis Procedure .....	70	Fail-safe (ADAS Control Unit) .....	93
<b>U1505 SIDE RDR R CAN 2 .....</b>	<b>72</b>	Fail-safe .....	94
DTC Description .....	72	Fail-safe (Side Radar) .....	94
Diagnosis Procedure .....	72	<b>OPERATION .....</b>	<b>95</b>
<b>U1506 SIDE RDR R CAN 1 .....</b>	<b>74</b>	<b>PFCW/FEB, BSW/RCTA .....</b>	<b>95</b>
DTC Description .....	74	PFCW/FEB, BSW/RCTA : Switch Name and Function .....	95
Diagnosis Procedure .....	74	<b>HANDLING PRECAUTION .....</b>	<b>96</b>
<b>U1507 LOST COMM(SIDE RDR R) .....</b>	<b>76</b>	Precautions for Predictive Forward Collision Warning .....	96
DTC Description .....	76	Precautions for Blind Spot Warning .....	96
Diagnosis Procedure .....	76	Precautions for Rear Cross Traffic Alert .....	97
<b>U1508 LOST COMM(SIDE RDR L) .....</b>	<b>77</b>		
DTC Description .....	77		
Diagnosis Procedure .....	77		
<b>POWER SUPPLY AND GROUND CIRCUIT ....</b>	<b>79</b>		
Diagnosis Procedure .....	79		

<b>DIAGNOSIS SYSTEM (ADAS CONTROL UNIT)</b> .....	<b>98</b>	RCTA : Work Procedure .....	144	
CONSULT Function (ICC/ADAS) .....	98	<b>DTC/CIRCUIT DIAGNOSIS</b> .....	<b>145</b>	A
<b>DIAGNOSIS SYSTEM (ICC SENSOR)</b> .....	<b>104</b>	<b>C1B50 SIDE RADAR MALFUNCTION</b> .....	<b>145</b>	B
CONSULT Function (LASER/RADAR) .....	104	DTC Description .....	145	
<b>DIAGNOSIS SYSTEM (SIDE RADAR LH)</b> .....	<b>108</b>	Diagnosis Procedure .....	145	
CONSULT Function (SIDE RADAR LEFT) .....	108	<b>C1B51 BLIND SPOT WARNING INDICATOR SHORT CIRCUIT</b> .....	<b>146</b>	C
<b>DIAGNOSIS SYSTEM (SIDE RADAR RH)</b> .....	<b>110</b>	DTC Description .....	146	
CONSULT Function (SIDE RADAR RIGHT) .....	110	Diagnosis Procedure .....	146	D
<b>ECU DIAGNOSIS INFORMATION</b> .....	<b>112</b>	<b>C1B52 BLIND SPOT WARNING INDICATOR OPEN CIRCUIT</b> .....	<b>148</b>	E
<b>ADAS CONTROL UNIT</b> .....	<b>112</b>	DTC Description .....	148	
Reference Value .....	112	Diagnosis Procedure .....	148	
Fail-safe (ADAS Control Unit) .....	116	<b>C1B55 RADAR BLOCKAGE</b> .....	<b>150</b>	F
DTC Inspection Priority Chart .....	116	DTC Description .....	150	
DTC Index .....	117	Diagnosis Procedure .....	150	
<b>ICC SENSOR</b> .....	<b>119</b>	<b>U0104 ADAS CAN 1</b> .....	<b>152</b>	G
Reference Value .....	119	DTC Description .....	152	
Fail-safe .....	122	Diagnosis Procedure .....	152	
DTC Inspection Priority Chart .....	122	<b>U0405 ADAS CAN 2</b> .....	<b>154</b>	H
DTC Index .....	123	DTC Description .....	154	
<b>SIDE RADAR LH</b> .....	<b>126</b>	Diagnosis Procedure .....	154	I
Reference Value .....	126	<b>U1000 CAN COMM CIRCUIT</b> .....	<b>156</b>	
Fail-safe (Side Radar) .....	127	<b>SIDE RADAR LH</b> .....	<b>156</b>	J
DTC Inspection Priority Chart .....	127	SIDE RADAR LH : Description .....	156	
DTC Index .....	127	SIDE RADAR LH : DTC Description .....	156	
<b>SIDE RADAR RH</b> .....	<b>128</b>	SIDE RADAR LH : Diagnosis Procedure .....	156	K
Reference Value .....	128	<b>SIDE RADAR RH</b> .....	<b>157</b>	
Fail-safe (Side Radar) .....	129	SIDE RADAR RH : Description .....	157	
DTC Inspection Priority Chart .....	129	SIDE RADAR RH : DTC Description .....	157	
DTC Index .....	129	SIDE RADAR RH : Diagnosis Procedure .....	158	L
<b>WIRING DIAGRAM</b> .....	<b>130</b>	<b>U1010 CONTROL UNIT (CAN)</b> .....	<b>159</b>	
<b>DRIVER ASSISTANCE SYSTEMS</b> .....	<b>130</b>	<b>SIDE RADAR LH</b> .....	<b>159</b>	M
Wiring Diagram .....	130	SIDE RADAR LH : Description .....	159	
<b>BASIC INSPECTION</b> .....	<b>139</b>	SIDE RADAR LH : DTC Description .....	159	
<b>DIAGNOSIS AND REPAIR WORK FLOW</b> .....	<b>139</b>	SIDE RADAR LH : Diagnosis Procedure .....	159	N
Work Flow .....	139	<b>SIDE RADAR RH</b> .....	<b>159</b>	
<b>ADDITIONAL SERVICE WHEN REPLACING ICC SENSOR</b> .....	<b>142</b>	SIDE RADAR RH : Description .....	159	
Description .....	142	SIDE RADAR RH : DTC Description .....	160	
Work Procedure .....	142	SIDE RADAR RH : Diagnosis Procedure .....	160	DAS
<b>ACTION TEST</b> .....	<b>143</b>	<b>POWER SUPPLY AND GROUND CIRCUIT</b> ..	<b>161</b>	P
<b>BLIND SPOT WARNING</b> .....	<b>143</b>	<b>SIDE RADAR LH</b> .....	<b>161</b>	
BLIND SPOT WARNING : Description .....	143	SIDE RADAR LH : Diagnosis Procedure .....	161	
BLIND SPOT WARNING : Work Procedure .....	143	<b>SIDE RADAR RH</b> .....	<b>161</b>	
<b>RCTA</b> .....	<b>143</b>	SIDE RADAR RH : Diagnosis Procedure .....	161	
RCTA : Description .....	144	<b>RIGHT/LEFT SWITCHING SIGNAL CIRCUIT</b>		

Diagnosis Procedure .....	163	<b>PREPARATION .....</b>	<b>181</b>
<b>SYMPTOM DIAGNOSIS .....</b>	<b>164</b>	<b>PREPARATION .....</b>	<b>181</b>
<b>DRIVER ASSISTANCE SYSTEM SYMPTOMS .....</b>	<b>164</b>	Special Service Tool .....	181
Symptom Table .....	164	<b>SYSTEM DESCRIPTION .....</b>	<b>182</b>
<b>SYSTEM SETTINGS CANNOT BE TURNED ON/OFF ON THE INTEGRAL SWITCH .....</b>	<b>165</b>	<b>COMPONENT PARTS .....</b>	<b>182</b>
Description .....	165	Component Parts Location .....	182
Diagnosis Procedure .....	165	Chassis Control Module .....	182
<b>CHIME DOES NOT SOUND .....</b>	<b>166</b>	<b>SYSTEM .....</b>	<b>183</b>
Description .....	166	System Description .....	183
Diagnosis Procedure .....	166	Fail-Safe (Chassis Control Module) .....	184
<b>FREQUENTLY CANNOT DETECT THE VEHICLE AHEAD / DETECTION ZONE IS SHORT. ....</b>	<b>167</b>	<b>ACTIVE TRACE CONTROL (DYNAMIC CORNERING ENHANCEMENT) FUNCTION .....</b>	<b>186</b>
Description .....	167	ACTIVE TRACE CONTROL (DYNAMIC CORNERING ENHANCEMENT) FUNCTION : System Description .....	186
Diagnosis Procedure .....	167	<b>ACTIVE ENGINE BRAKE FUNCTION .....</b>	<b>192</b>
<b>THE SYSTEM DOES NOT DETECT THE VEHICLE AHEAD AT ALL .....</b>	<b>169</b>	ACTIVE ENGINE BRAKE FUNCTION : System Description .....	192
Description .....	169	<b>ACTIVE RIDE CONTROL FUNCTION .....</b>	<b>194</b>
Diagnosis Procedure .....	169	ACTIVE RIDE CONTROL FUNCTION : System Description .....	195
<b>NORMAL OPERATING CONDITION .....</b>	<b>170</b>	<b>HANDLING PRECAUTION .....</b>	<b>200</b>
Description .....	170	Precautions for Chassis Control (Engine Brake, Active Ride, and Active Trace) .....	200
<b>REMOVAL AND INSTALLATION .....</b>	<b>172</b>	<b>DIAGNOSIS SYSTEM (CHASSIS CONTROL MODULE) .....</b>	<b>201</b>
<b>ICC SENSOR .....</b>	<b>172</b>	CONSULT Function .....	201
Exploded View .....	172	<b>ECU DIAGNOSIS INFORMATION .....</b>	<b>205</b>
Removal and Installation .....	172	<b>CHASSIS CONTROL MODULE .....</b>	<b>205</b>
<b>ICC STEERING SWITCH .....</b>	<b>174</b>	Reference Value .....	205
Exploded View .....	174	Fail-Safe (Chassis Control Module) .....	208
Removal and Installation .....	174	DTC Inspection Priority Chart .....	209
<b>WARNING BUZZER .....</b>	<b>176</b>	DTC Index .....	210
Exploded View .....	176	<b>WIRING DIAGRAM .....</b>	<b>212</b>
Removal and Installation .....	176	<b>CHASSIS CONTROL .....</b>	<b>212</b>
<b>SIDE RADAR .....</b>	<b>177</b>	Wiring Diagram .....	212
Exploded View .....	177	<b>BASIC INSPECTION .....</b>	<b>214</b>
Removal and Installation .....	177	<b>DIAGNOSIS AND REPAIR WORK FLOW .....</b>	<b>214</b>
<b>BLIND SPOT WARNING INDICATOR .....</b>	<b>178</b>	Work Flow .....	214
Exploded View .....	178	Diagnostic Work Sheet .....	215
Removal and Installation .....	178	<b>ADDITIONAL SERVICE WHEN REPLACING CHASSIS CONTROL MODULE .....</b>	<b>217</b>
<b>CHASSIS CONTROL</b>		Description .....	217
<b>PRECAUTION .....</b>	<b>179</b>	<b>CONFIGURATION (CHASSIS CONTROL MODULE) .....</b>	<b>218</b>
<b>PRECAUTIONS .....</b>	<b>179</b>		
Precaution for Supplemental Restraint System (SRS) "AIR BAG" and "SEAT BELT PRE-TENSIONER" .....	179		
Precaution for Work .....	179		
Precautions for Harness Repair .....	180		
Precautions for Chassis control .....	180		



Work Procedure .....	218	<b>C1BB7-00 CONTROL MODULE .....</b>	<b>243</b>	
<b>DTC/CIRCUIT DIAGNOSIS .....</b>	<b>220</b>	DTC Description .....	243	A
<b>C1B92-00 BRAKE CONTROL SYSTEM .....</b>	<b>220</b>	Diagnosis Procedure .....	243	
DTC Description .....	220	<b>C1BB8-00 CONTROL MODULE .....</b>	<b>244</b>	B
Diagnosis Procedure .....	220	DTC Description .....	244	
<b>C1B93-00 ENGINE SYSTEM .....</b>	<b>222</b>	Diagnosis Procedure .....	244	
DTC Description .....	222	<b>C1BB9-00 CONTROL MODULE .....</b>	<b>245</b>	C
Diagnosis Procedure .....	222	DTC Description .....	245	
<b>C1B94-00 TRANSMISSION SYSTEM .....</b>	<b>224</b>	Diagnosis Procedure .....	245	
DTC Description .....	224	<b>C1BBA-00 CONTROL MODULE .....</b>	<b>246</b>	D
Diagnosis Procedure .....	224	DTC Description .....	246	
<b>C1B95-00 CONTROL MODULE .....</b>	<b>226</b>	Diagnosis Procedure .....	246	E
DTC Description .....	226	<b>C1BBB-00 CONTROL MODULE .....</b>	<b>247</b>	
Diagnosis Procedure .....	226	DTC Description .....	247	F
<b>C1B99-00 CONTROL MODULE .....</b>	<b>227</b>	Diagnosis Procedure .....	247	
DTC Description .....	227	<b>C1BBC-00 CONTROL MODULE .....</b>	<b>248</b>	G
Diagnosis Procedure .....	227	DTC Description .....	248	
<b>C1BA0-00 ADAS/CHASSIS CONTROL BRAKE SYSTEM .....</b>	<b>228</b>	Diagnosis Procedure .....	248	
DTC Description .....	228	<b>C1BBD-00 VARIANT CODING .....</b>	<b>249</b>	H
Diagnosis Procedure .....	228	DTC Description .....	249	
<b>C1BA2-00 STEERING ANGLE SENSOR .....</b>	<b>230</b>	Diagnosis Procedure .....	249	
DTC Description .....	230	<b>C1BC0-00 FRONT RIGHT WHEEL SENSOR ..</b>	<b>250</b>	I
Diagnosis Procedure .....	230	DTC Description .....	250	
<b>C1BA5-00 ADAS/CHASSIS CONTROL EN- GINE SYSTEM .....</b>	<b>232</b>	Diagnosis Procedure .....	250	
DTC Description .....	232	<b>C1BC1-00 FRONT LEFT WHEEL SENSOR ..</b>	<b>252</b>	J
Diagnosis Procedure .....	232	DTC Description .....	252	
<b>C1BAB-00 STOP LAMP SWITCH .....</b>	<b>234</b>	Diagnosis Procedure .....	252	
DTC Description .....	234	<b>C1BC2-00 REAR RIGHT WHEEL SENSOR ..</b>	<b>254</b>	K
Diagnosis Procedure .....	234	DTC Description .....	254	
<b>C1BB2-00 CONTROL MODULE .....</b>	<b>236</b>	Diagnosis Procedure .....	254	
DTC Description .....	236	<b>C1BC3-00 REAR LEFT WHEEL SENSOR ....</b>	<b>256</b>	L
Diagnosis Procedure .....	236	DTC Description .....	256	
<b>C1BB3-00 CONTROL MODULE .....</b>	<b>237</b>	Diagnosis Procedure .....	256	
DTC Description .....	237	<b>C1BC4-00 DECEL G SENSOR .....</b>	<b>258</b>	M
Diagnosis Procedure .....	237	DTC Description .....	258	
<b>C1BB4-00 CONTROL MODULE .....</b>	<b>238</b>	Diagnosis Procedure .....	258	N
DTC Description .....	238	<b>C1BC5-00 SIDE G SENSOR .....</b>	<b>260</b>	
Diagnosis Procedure .....	238	DTC Description .....	260	
<b>C1BB5-00 IGNITION POWER SUPPLY .....</b>	<b>239</b>	Diagnosis Procedure .....	260	DAS
DTC Description .....	239	<b>C1BC6-00 PRESSURE SENSOR .....</b>	<b>262</b>	
Diagnosis Procedure .....	239	DTC Description .....	262	
<b>C1BB6-00 IGNITION POWER SUPPLY .....</b>	<b>241</b>	Diagnosis Procedure .....	262	P
DTC Description .....	241	<b>U1000-00 CAN COMM CIRCUIT .....</b>	<b>264</b>	
Diagnosis Procedure .....	241	DTC Logic .....	264	
		Diagnosis Procedure .....	264	
		<b>U1A34-00 BRAKE CONTROL COMMUNICA- TION .....</b>	<b>265</b>	

DTC Description .....	265	Diagnosis Procedure .....	279
Diagnosis Procedure .....	265		
<b>U1A35-00 BRAKE CONTROL COMMUNICA-</b>		<b>U1A4A-00 CONTROL MODULE (CAN) .....</b>	<b>281</b>
<b>TION .....</b>	<b>267</b>	DTC Description .....	281
DTC Description .....	267	Diagnosis Procedure .....	281
Diagnosis Procedure .....	267	<b>U1A4B-00 CONTROL MODULE (CAN) .....</b>	<b>282</b>
<b>U1A36-00 BCM/IPDM COMMUNICATION ....</b>	<b>269</b>	DTC Description .....	282
DTC Description .....	269	Diagnosis Procedure .....	282
Diagnosis Procedure .....	269	<b>U1A4E-00 ECM COMMUNICATION .....</b>	<b>283</b>
<b>U1A39-00 COMBINATION METER COMMU-</b>		DTC Description .....	283
<b>NICATION .....</b>	<b>271</b>	Diagnosis Procedure .....	283
DTC Description .....	271	<b>POWER SUPPLY AND GROUND CIRCUIT ...</b>	<b>285</b>
Diagnosis Procedure .....	271	Diagnosis Procedure .....	285
<b>U1A3B-00 TCM COMMUNICATION .....</b>	<b>273</b>	<b>SYMPTOM DIAGNOSIS .....</b>	<b>286</b>
DTC Description .....	273	<b>CHASSIS CONTROL .....</b>	<b>286</b>
Diagnosis Procedure .....	273	Active Engine Brake .....	286
<b>U1A42-00 STEERING ANGLE SENSOR</b>		Active Ride Control .....	286
<b>COMMUNICATION .....</b>	<b>275</b>	Active Trace Control .....	287
DTC Description .....	275	<b>NORMAL OPERATING CONDITION .....</b>	<b>289</b>
Diagnosis Procedure .....	275	Description .....	289
<b>U1A43-00 STEERING ANGLE SENSOR</b>		<b>REMOVAL AND INSTALLATION .....</b>	<b>290</b>
<b>COMMUNICATION .....</b>	<b>277</b>	<b>CHASSIS CONTROL MODULE .....</b>	<b>290</b>
DTC Description .....	277	Exploded View .....	290
Diagnosis Procedure .....	277	Removal and Installation .....	290
<b>U1A48-00 ECM COMMUNICATION .....</b>	<b>279</b>		
DTC Description .....	279		

PRECAUTION

PRECAUTIONS

Precaution for Supplemental Restraint System (SRS) "AIR BAG" and "SEAT BELT PRE-TENSIONER"

INFOID:000000011953057

The Supplemental Restraint System such as "AIR BAG" and "SEAT BELT PRE-TENSIONER", used along with a front seat belt, helps to reduce the risk or severity of injury to the driver and front passenger for certain types of collision. Information necessary to service the system safely is included in the SR and SB section of this Service Manual.

**WARNING:**

- To avoid rendering the SRS inoperative, which could increase the risk of personal injury or death in the event of a collision which would result in air bag inflation, all maintenance must be performed by an authorized NISSAN/INFINITI dealer.
- Improper maintenance, including incorrect removal and installation of the SRS, can lead to personal injury caused by unintentional activation of the system. For removal of Spiral Cable and Air Bag Module, see the SR section.
- Do not use electrical test equipment on any circuit related to the SRS unless instructed to in this Service Manual. SRS wiring harnesses can be identified by yellow and/or orange harnesses or harness connectors.

PRECAUTIONS WHEN USING POWER TOOLS (AIR OR ELECTRIC) AND HAMMERS

**WARNING:**

- When working near the Airbag Diagnosis Sensor Unit or other Airbag System sensors with the Ignition ON or engine running, DO NOT use air or electric power tools or strike near the sensor(s) with a hammer. Heavy vibration could activate the sensor(s) and deploy the air bag(s), possibly causing serious injury.
- When using air or electric power tools or hammers, always switch the Ignition OFF, disconnect the battery and wait at least three minutes before performing any service.

Precaution for Work

INFOID:000000012461156

- When removing or disassembling each component, be careful not to damage or deform it. If a component may be subject to interference, be sure to protect it with a shop cloth.
- When removing (disengaging) components with a screwdriver or similar tool, be sure to wrap the component with a shop cloth or vinyl tape to protect it.
- Protect the removed parts with a shop cloth and prevent them from being dropped.
- Replace a deformed or damaged clip.
- If a part is specified as a non-reusable part, always replace it with a new one.
- Be sure to tighten bolts and nuts securely to the specified torque.
- After installation is complete, be sure to check that each part works properly.
- Follow the steps below to clean components:
  - Water soluble dirt:
    - Dip a soft cloth into lukewarm water, wring the water out of the cloth and wipe the dirty area.
    - Then rub with a soft, dry cloth.
  - Oily dirt:
    - Dip a soft cloth into lukewarm water with mild detergent (concentration: within 2 to 3%) and wipe the dirty area.
    - Then dip a cloth into fresh water, wring the water out of the cloth and wipe the detergent off.
    - Then rub with a soft, dry cloth.
  - Do not use organic solvent such as thinner, benzene, alcohol or gasoline.
  - For genuine leather seats, use a genuine leather seat cleaner.

Precautions For Harness Repair

INFOID:000000011953058

ITS communication uses a twisted pair line. Be careful when repairing it.

A  
B  
C  
D  
E  
F  
G  
H  
I  
J  
K  
L  
M  
N  
P



## PRECAUTIONS

[ADAS CONTROL UNIT]

### < PRECAUTION >

- Solder the repaired area and wrap tape around the soldered area.

**NOTE:**

A fray of twisted lines must be within 110 mm (4.33 in).

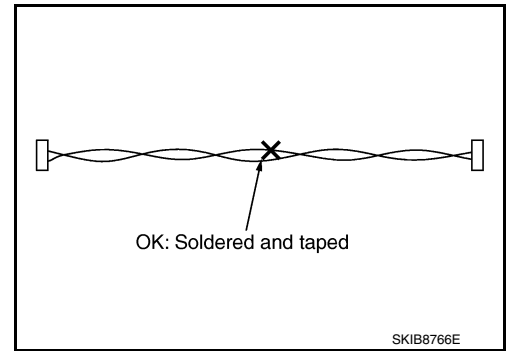

- Bypass connection is never allowed at the repaired area.

**NOTE:**

Bypass connection may cause ITS communication error. The spliced wire becomes separated and the characteristics of twisted line are lost.

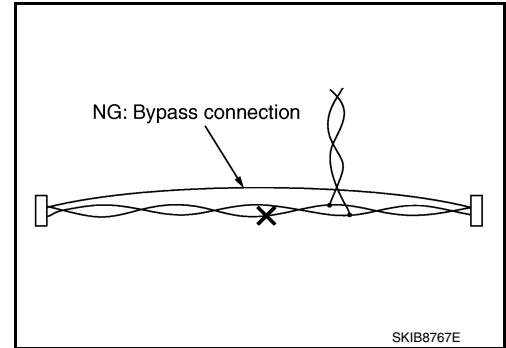

SYSTEM DESCRIPTION

COMPONENT PARTS

Component Parts Location

INFOID:000000011953059

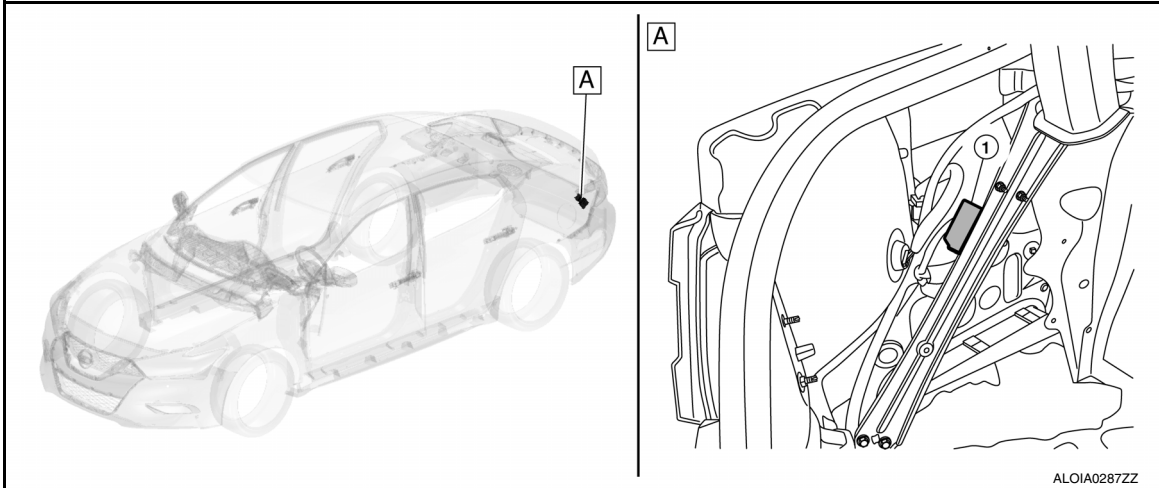

A. View with trunk side finisher LH removed.

No.	Component	Description
1.	ADAS control unit	<ul style="list-style-type: none"> <li>Controls each system, based on CAN communication and ITS communication signals received from each control unit.</li> <li>Transmits signals necessary for control between CAN communication and ITS communication.</li> </ul>

ADAS Control Unit

INFOID:000000011953060

- ADAS control unit is installed in the trunk LH side.
- Communicates with each control unit via CAN communication and ITS communication.
- ADAS control unit with gateway function is for system control signals that are transmitted to each control unit between CAN communication and ITS communication by the ADAS control unit.
- ADAS control unit controls each system, based on ITS communication signals and CAN communication signals from each control unit.

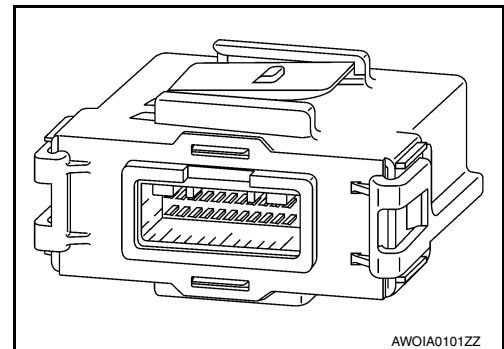

DAS

# SYSTEM

< SYSTEM DESCRIPTION >

[ADAS CONTROL UNIT]

## SYSTEM

### System Description

INFOID:000000011953061

### SYSTEM DIAGRAM

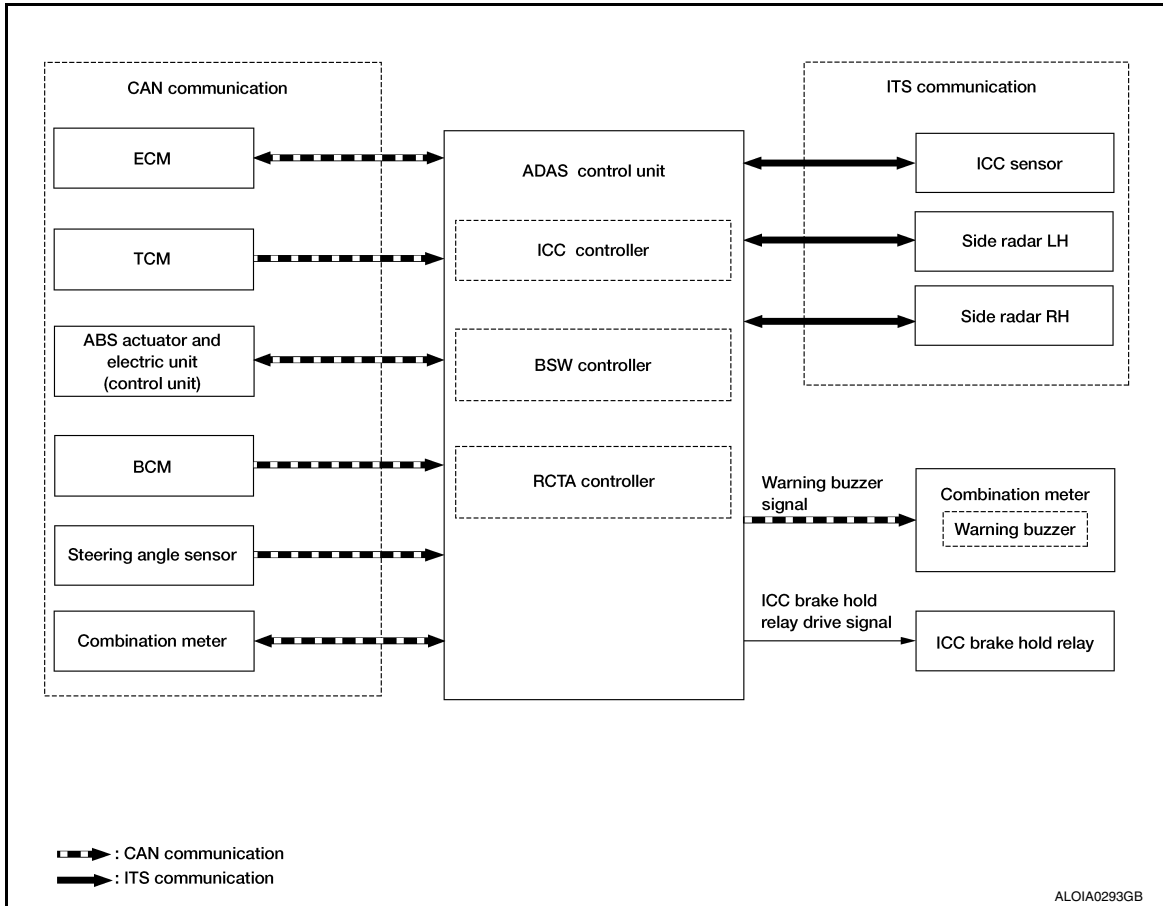

### ADAS CONTROL UNIT INPUT/OUTPUT SIGNAL ITEM

#### Input Signal Item

Transmit unit	Signal name		Description	
ECM	CAN communication	Closed throttle position signal	Receives idle position state (ON/OFF).	
		Accelerator pedal position signal	Receives accelerator pedal position (angle).	
		ICC prohibition signal	Receives an operable/inoperable state of the ICC system.	
		Engine speed signal	Receives engine speed.	
		ICC steering switch signal	MAIN switch signal	Receives the operational state of the ICC steering switch.
			SET/ - switch signal	
			CANCEL switch signal	
			RES/ + switch signal	
DISTANCE switch signal				
Stop lamp switch signal	Receives an operational state of the brake pedal.			
Brake pedal position switch signal	Receives an operational state of the brake pedal.			

# SYSTEM

< SYSTEM DESCRIPTION >

[ADAS CONTROL UNIT]

Transmit unit	Signal name		Description
TCM	CAN communication	Input speed signal	Receives the number of revolutions of input shaft.
		Current gear position signal	Receives a current gear position.
		Shift selector position signal	Receives a shift selector position.
		Output shaft revolution signal	Receives the number of revolutions of output shaft.
ABS actuator and electric unit (control unit)	CAN communication	Vehicle speed signal (ABS)	Receives wheel speeds of four wheels.
		Yaw rate signal	Receives yaw rate acting on the vehicle.
		Stop lamp switch signal	Receives an operational state of the brake pedal.
Combination meter	CAN communication	Parking brake switch signal	Receives an operational state of the parking brake.
		System selection signal	Receives a selection state of each item in "Driving Aids" selected with the integral switch of the information display.
BCM	CAN communication	Turn indicator signal	Receives an operational state of the turn signal lamp and the hazard lamp.
		Dimmer signal	Receives ON/OFF state of dimmer signal.
Steering angle sensor	CAN communication	Steering angle sensor malfunction signal	Receives a malfunction state of steering angle sensor
		Steering angle sensor signal	Receives the number of revolutions and turning direction of the steering wheel.
		Steering angle speed signal	Receives the turning angle speed of the steering wheel.
ICC sensor	ITS communication	ICC sensor signal	Receives detection results, such as the presence or absence of a leading vehicle and distance from the vehicle.
Side radar LH, RH	ITS communication	Vehicle detection signal	Receives vehicle detection condition of detection zone.

## Output Signal Item

Reception unit	Signal name		Description
ECM	CAN communication	ICC operation signal	Transmits an ICC operation signal necessary for Intelligent Cruise Control.
ABS actuator and electric unit (control unit)	CAN communication	Brake fluid pressure control signal	Transmits a brake fluid pressure control signal to activate the brake.

A  
B  
C  
D  
E  
F  
G  
H  
I  
J  
K  
L  
M  
N  
P

DAS

# SYSTEM

< SYSTEM DESCRIPTION >

[ADAS CONTROL UNIT]

Reception unit	Signal name		Description
Combination meter	CAN communication	Meter display signal	Transmits a signal to display a state of the system on the information display.
		Vehicle ahead detection indicator signal	
		Set vehicle speed indicator signal	
		Set distance indicator signal	
		SET switch indicator signal	
		ON/OFF switch indicator signal	
		FEB system display signal	
		PFCW system display signal	
		BSW system display signal	
		FEB warning lamp signal	<ul style="list-style-type: none"> <li>• Transmits a signal to turn ON the lamp.</li> <li>• Transmits an ON/OFF state of the Forward Emergency Brake.</li> </ul>
ICC sensor	ITS communication	ADAS control status	Transmits ADAS status.
Side radar LH, RH	ITS communication	Vehicle speed signal	Transmits a vehicle speed calculated by the ADAS control unit.
		Blind Spot Warning indicator signal	Transmits a Blind Spot Warning indicator signal to turn ON the Blind Spot Warning indicator.
		Blind Spot Warning indicator dimmer signal	Transmits a Blind Spot Warning indicator dimmer signal to dim Blind Spot Warning indicator.
ICC brake hold relay	ICC brake hold relay drive signal		Activates the brake hold relay and turns ON the stop lamp.

## DESCRIPTION

- ADAS\* control unit controls the following systems based on ITS communication signal and CAN communication signal from each control unit.

**NOTE:**

\*: Advanced Driver Assistance Systems

- Intelligent Cruise Control (ICC)
- Blind Spot Warning (BSW)
- Rear Cross Traffic Alert (RCTA)

System	Reference
Intelligent Cruise Control (ICC)	<a href="#">CCS-11. "System Description"</a>
Forward Emergency Braking (FEB)	<a href="#">BRC-203. "BRAKE ASSIST (WITH PREVIEW FUNCTION) : System Description-Forward Emergency Braking"</a>
Predictive Forward Collision Warning (PFCW)	<a href="#">DAS-88. "PFCW : System Description"</a>
Blind Spot Warning (BSW)	<a href="#">DAS-90. "BSW : System Description"</a>
Rear Cross Traffic Alert (RCTA)	<a href="#">DAS-92. "RCTA : System Description"</a>

## Fail-safe (ADAS Control Unit)

INFOID:000000011953062

If a malfunction occurs in each system, ADAS control unit cancels each control, sounds a beep, and turns ON the warning or indicator lamp.



# SYSTEM

< SYSTEM DESCRIPTION >

[ADAS CONTROL UNIT]

System	Buzzer	Warning lamp/Warning display	Description
Intelligent Cruise Control (ICC)	High-pitched tone	ICC system warning	Cancel
Forward Emergency Braking (FEB)	High-pitched tone	FEB warning lamp (Yellow)	Cancel
Predictive Forward Collision Warning (PFCW)	High-pitched tone	FEB warning lamp (Yellow)	Cancel
Blind Spot Warning (BSW)	Low-pitched tone	BSW system warning	Cancel
Rear Cross Traffic Alert (RCTA)	—	BSW system warning	Cancel

A  
B  
C  
D  
E  
F  
G  
H  
I  
J  
K  
L  
M  
N  
P

DAS

# DIAGNOSIS SYSTEM (ADAS CONTROL UNIT)

< SYSTEM DESCRIPTION >

[ADAS CONTROL UNIT]

## DIAGNOSIS SYSTEM (ADAS CONTROL UNIT)

### CONSULT Function (ICC/ADAS)

INFOID:000000011953063

#### APPLICATION ITEMS

CONSULT performs the following functions via CAN communication using ADAS control unit:

Diagnosis mode	Description
Configuration	<ul style="list-style-type: none"> <li>The vehicle specification that is written in ADAS control unit can be displayed or stored.</li> <li>The vehicle specification can be written when ADAS control unit is replaced.</li> </ul>
Work support	Displays causes of automatic system cancellation that occurred during system control.
Self Diagnostic Result	Displays the name of a malfunctioning system stored in the ADAS control unit.
Data Monitor	Displays ADAS control unit input/output data in real time.
Active Test	Enables an operational check of a load by transmitting a driving signal from the ADAS control unit to the load.
ECU Identification	Displays ADAS control unit part number.
CAN Diag Support Monitor	Displays a reception/transmission state of CAN communication and ITS communication.

#### CONFIGURATION

Configuration includes functions as follows:

Function	Description
Read/Write Configuration	Before Replace ECU Allows the reading of vehicle specification written in ADAS control unit to store the specification in CONSULT.
	After Replace ECU Allows the writing of the vehicle information stored in CONSULT into the ADAS control unit.
Manual Configuration	Allows the writing of the vehicle specification into the ADAS control unit by hand.

#### WORK SUPPORT

Work support items	Description
CAUSE OF AUTO-CANCEL 5	Displays causes of automatic system cancellation that occurred during control of the Intelligent Cruise Control (ICC).

#### NOTE:

- Causes of the maximum five cancellations (system cancel) are displayed.
- The displayed cancellation causes display the number of the ignition switch ON/OFF up to 254. It is fixed to 254 if it is over 254. It returns to 0 when the same cancellation cause is detected again.

Display Items for the Cause of Automatic Cancellation 1

Cause of cancellation	Intelligent Cruise Control (ICC)	Description
CAN COMM ERROR	×	ADAS control unit received an abnormal signal with CAN communication.
NO RECORD	×	—

#### SELF DIAGNOSTIC RESULT

Refer to [DAS-25. "DTC Index"](#).

# DIAGNOSIS SYSTEM (ADAS CONTROL UNIT)

[ADAS CONTROL UNIT]

## < SYSTEM DESCRIPTION >

### NOTE:

- The details of time display are as per the following:
- CRNT: A malfunction is detected now.
- PAST: A malfunction was detected in the past.
- ODO/TRIP METER (Mileage) and VOLTAGE (IGN voltage) are displayed on FFD (Freeze Frame Data).

### DATA MONITOR

#### NOTE:

The following table includes information (items) inapplicable to this vehicle. For information (items) applicable to this vehicle, refer to CONSULT display items.

Monitored item [Unit]	ALL SIG (ICC)	MAIN SIG (ICC)	MAIN SIG (BSW)	Description
MAIN SW [On/Off]	×	×	×	Indicates [ON/OFF] status as judged from ICC steering switch.
SET/COAST SW [On/Off]	×	×		Indicates [ON/OFF] status as judged from ICC steering switch.
CANCEL SW [On/Off]	×	×		Indicates [ON/OFF] status as judged from ICC steering switch.
RESUME/ACC SW [On/Off]	×	×		Indicates [ON/OFF] status as judged from ICC steering switch.
DISTANCE SW [On/Off]	×			Indicates [ON/OFF] status as judged from ICC steering switch.
CRUISE OPE [On/Off]	×	×		Indicates whether controlling or not (ON means "controlling").
BRAKE SW [On/Off]	×	×	×	Indicates [ON/OFF] status as judged from ICC brake switch signal (ECM transmits ICC brake switch signal through CAN communication).
STOP LAMP SW [On/Off]	×	×	×	Indicates [ON/OFF] status as judged from stop lamp switch signal (ECM transmits stop lamp switch signal through CAN communication).
IDLE SW [On/Off]	×			Indicates [ON/OFF] status of idle switch read from ADAS control unit through CAN communication (ECM transmits ON/OFF status through CAN communication).
SET DISTANCE [Short/Mid/Long]	×	×		Indicates set distance memorized in ADAS control unit.
CRUISE LAMP [On/Off]	×	×		Indicates [ON/OFF] status of MAIN switch indicator output.
OWN VHCL [On/Off]	×			<b>NOTE:</b> The item is displayed, but it is not monitored.
VHCL AHEAD [On/Off]	×			Indicates [ON/OFF] status of vehicle ahead detection indicator output.
ICC WARNING [On/Off]	×			Indicates [ON/OFF] status of ICC system warning lamp output.
VHCL SPEED SE [km/h] or [mph]	×	×	×	Indicates vehicle speed calculated from ADAS control unit through CAN communication [ABS actuator and electric unit (control unit) transmits vehicle speed signal (wheel speed) through CAN communication].
SET VHCL SPD [km/h] or [mph]	×	×		Indicates set vehicle speed memorized in ADAS control unit.
BUZZER O/P [On/Off]	×			Indicates [ON/OFF] status of ICC warning chime output.
THRTL SENSOR [deg]	×	×		<b>NOTE:</b> The item is displayed, but it is not monitored.
ENGINE RPM [rpm]	×			Indicates engine speed read from ADAS control unit through CAN communication (ECM transmits engine speed signal through CAN communication).
WIPER SW [OFF/LOW/HIGH]	×			Indicates wiper [OFF/LOW/HIGH] status (BCM transmits front wiper request signal through CAN communication).

# DIAGNOSIS SYSTEM (ADAS CONTROL UNIT)

< SYSTEM DESCRIPTION >

[ADAS CONTROL UNIT]

Monitored item [Unit]	ALL SIG (ICC)	MAIN SIG (ICC)	MAIN SIG (BSW)	Description
YAW RATE [deg/s]	×			<b>NOTE:</b> The item is displayed, but it is not monitored.
BA WARNING [On/Off]	×			Indicates [ON/OFF] status of FEB indicator lamp output.
STP LMP DRIVE [On/Off]	×	×		Indicates [ON/OFF] status of ICC brake hold relay drive output.
D POSITION SW [On/Off]	×			Indicates [ON/OFF] status of "D" or "M" positions read from ADAS control unit through CAN communication; ON when position "D" or "M" (TCM transmits shift selector position signal through CAN communication).
NP RANGE SW [On/Off]	×			Indicates shift selector position signal read from ADAS control unit through CAN communication (TCM transmits shift selector position signal through CAN communication).
PKB SW [On/Off]	×			Parking brake switch status [ON/OFF] judged from the parking brake switch signal that ADAS control unit receives via CAN communication is displayed (combination meter transmits the parking brake switch signal via CAN communication).
PWR SUP MONI [V]	×	×		Indicates ignition voltage input monitored by ADAS control unit.
VHCL SPD AT [km/h] or [mph]	×			Indicates vehicle speed calculated from CVT vehicle speed sensor read from ADAS control unit through CAN communication (TCM transmits CVT vehicle speed sensor signal through CAN communication).
THRTL OPENING [%]	×	×		Indicates throttle position read from ADAS control unit through CAN communication (ECM transmits accelerator pedal position signal through CAN communication).
GEAR [1, 2, 3, 4, 5, 6, 7]	×			Indicates CVT gear position read from ADAS control unit through CAN communication (TCM transmits current gear position signal through CAN communication).
CLUTCH SW SIG [On/Off]	×	×	×	Indicates [ON/OFF] status as judged from clutch pedal position signal (ECM transmits ICC clutch switch signal through CAN communication).
NP SW SIG [On/Off]	×			Indicates [ON/OFF] status as judged from park/neutral position switch signal (ECM transmits park/neutral position switch signal through CAN communication).
MODE SIG [OFF, ICC, ASCD]	×			Indicates the active mode from ICC or ASCD [conventional (fixed speed) cruise control mode].
SET DISP IND [On/Off]	×			Indicates [ON/OFF] status of SET switch indicator output.
DISTANCE [m]	×			Indicates the distance from the vehicle ahead.
RELATIVE SPD [m/s]	×			Indicates the relative speed of the vehicle ahead.
ON ROOT GUIDANCE [On/Off]	×			<b>NOTE:</b> The item is displayed, but it is not monitored.
DYNA ASIST SW [On/Off]	×	×	×	Indicates [ON/OFF] status as judged from ICC steering switch signal (ECM transmits ICC steering switch signal through CAN communication).
IBA SW [On/Off]	×	×		<b>NOTE:</b> The item is displayed, but it is not monitored.
NAVI ICC DISP [On/Off]				<b>NOTE:</b> The item is displayed, but it is not monitored.
Shift position [Off, P, R, N, D, M/T1 - 7]			×	Indicates shift selector position read from ADAS control unit through CAN communication (TCM transmits shift selector position signal through CAN communication).

# DIAGNOSIS SYSTEM (ADAS CONTROL UNIT)

< SYSTEM DESCRIPTION >

[ADAS CONTROL UNIT]

Monitored item [Unit]	ALL SIG (ICC)	MAIN SIG (ICC)	MAIN SIG (BSW)	Description
Turn signal [OFF/LH/RH/LH&RH]			×	Indicates turn signal operation status read from ADAS control unit through CAN communication (BCM transmits turn indicator signal through CAN communication).
SIDE G [G]			×	Indicates lateral G acting on the vehicle. This lateral G is judged from a side G sensor signal read by ADAS control unit via CAN communication. (The ABS actuator and electric unit (control unit) transmits a side G sensor signal via CAN communication).
FUNC ITEM (FCW) [On/Off]	×	×	×	Indicates system which can be set to ON/OFF by selecting "Driver Assistance" ⇒ "Emergency Brake" of the integral switch: Forward Emergency Braking.
FUNC ITEM (BSW) [On/Off]	×	×	×	Indicates system which can be set to ON/OFF by selecting "Driver Assistance" ⇒ "Blind Spot" of the integral switch: Blind Spot Warning.
FUNC ITEM (NV-ICC) [Off]	×	×	×	<b>NOTE:</b> The item is displayed, but it is not monitored.
FCW SELECT [On/Off]	×	×	×	Indicates an ON/OFF state of the PFCW system. The PFCW system can be set to ON/OFF by selecting "Driver Assistance" ⇒ "Emergency Brake" of the integral switch.
BSW SELECT [On/Off]	×	×	×	Indicates an ON/OFF state of the BSW system. The BSW system can be set to ON/OFF by selecting "Driver Assistance" ⇒ "Blind Spot" of the integral switch.
NAVI ICC SELECT [Off]	×	×	×	<b>NOTE:</b> The item is displayed, but it is not monitored.
SYS SELECTABILITY [On/Off]	×	×	×	Indicates the availability of ON/OFF switching for "Driving Aids" items received from the integral switch via CAN communication.
BSW/BSI WARN LMP [On/Off]			×	Indicates [ON/OFF] status of Blind Spot Warning malfunction.
BSW SYSTEM ON [On/Off]			×	Indicates [ON/OFF] status of BSW system.
FCW SYSTEM ON [On/Off]	×	×		Indicates [ON/OFF] status of PFCW system.
BATTERY CIRCUIT OFF [On/Off]	×			<b>NOTE:</b> The item is displayed, but it is not used.
SYSTEM CANCEL MESSAGE [NOREQ/SLIP/VDC OFF]	×	×	×	Indicates [ON/OFF] status of system cancel display output.
BSW ON INDICATOR [On/Off]			×	Indicates [ON/OFF] status of BSW system ON display output.
SIDE RADAR BLOCK COND [On/Off]			×	Indicates [ON/OFF] status of side radar with dirt or foreign materials.
BSW IND BRIGHT- NESS [Nothing/Bright/Normal/ Dark]			×	Indicates status of brightness of Blind Spot Warning indicator.
SL MAIN SW [On/Off]		×		Indicates [ON/OFF] status as judged from steering switch.
FUNC ITEM(FEB) [On/Off]	×			Indicates system which can be set to ON/OFF by selecting "Driver Assistance" ⇒ "Emergency Brake" of the integral switch: Forward Emergency Braking

A  
B  
C  
D  
E  
F  
G  
H  
I  
J  
K  
L  
M  
N  
P

DAS

# DIAGNOSIS SYSTEM (ADAS CONTROL UNIT)

< SYSTEM DESCRIPTION >

[ADAS CONTROL UNIT]

Monitored item [Unit]	ALL SIG (ICC)	MAIN SIG (ICC)	MAIN SIG (BSW)	Description
FEB SELECT [On/Off]	×			Indicates an ON/OFF state of the FEB system. The FEB system can be set to ON/OFF by selecting “Driver Assistance”→“Emergency Brake” of the integral switch.
FEB SW [On/Off]	×			Indicates [ON/OFF] status of FEB system.
SL TARGET VEHICLE SPEED [km/h] or [mph]	×			Indicates set vehicle speed memorized in ADAS control unit.
SL SET LAMP [On/Off]	×			Indicates [ON/OFF] status of speed limiter SET display output.
SL LIMIT LAMP [On/Off]	×			Indicates [ON/OFF] status of speed limiter MAIN switch display output.
ASCD CANCEL (LOW SPEED) [NON/CUT]	×			Indicates the vehicle cruise condition. <ul style="list-style-type: none"> <li>• NON: Vehicle speed is maintained at the ASCD set speed.</li> <li>• CUT: Vehicle speed decreased to excessively low, and ASCD operation is cut off.</li> </ul>
ASCD CANCEL (SPEED DIFF) [NON/CUT]	×			Indicates the vehicle cruise condition. <ul style="list-style-type: none"> <li>• NON: Vehicle speed is maintained at the ASCD set speed.</li> <li>• CUT: Vehicle speed decreased to excessively low compared with the ASCD set speed, and ASCD operation is cut off.</li> </ul>
KICK DOWN [On/Off]	×			Displays Kick down state. <ul style="list-style-type: none"> <li>• On: Accelerator pedal is depressed.</li> <li>• Off: Accelerator pedal is fully released.</li> </ul>

## ACTIVE TEST

### CAUTION:

- **Never perform “Active Test” while driving the vehicle.**
- **The “Active Test” cannot be performed when the following systems malfunction is displayed.**
- **ICC system**
- **Blind Spot Warning/RCTA**
- **PFCW/FEB**
- **The “Active Test” cannot be performed when the FEB warning lamp is illuminated.**
- **The “Active Test” cannot be performed when the ICC System is ON.**

Test item	Description
METER LAMP	The FEB warning lamp can be illuminated by ON/OFF operation as necessary.
STOP LAMP	The ICC brake hold relay can be operated by ON/OFF operation as necessary, and the stop lamp can be illuminated.
METER BUZZER	Sounds a buzzer used for BSW, RCTA, ICC, PFCW and FEB by arbitrarily operating ON/OFF.
BRAKE ACTUATOR 1	Activates the brake by an arbitrary operation.
BRAKE ACTUATOR 2	
BRAKE ACTUATOR 3	

## METER LAMP

### NOTE:

The test can be performed only when the engine is running.

Test item	Operation	Description	FEB warning lamp
METER LAMP	Off	Stops sending the FEB warning lamp signal to exit from the test.	OFF
	On	Transmits the FEB warning lamp signal to the combination meter via CAN communication.	ON

## STOP LAMP

# DIAGNOSIS SYSTEM (ADAS CONTROL UNIT)

< SYSTEM DESCRIPTION >

[ADAS CONTROL UNIT]

Test item	Operation	Description	Stop lamp
STOP LAMP	Off	Stops transmitting the ICC brake hold relay drive signal to end the test.	OFF
	On	Transmits the ICC brake hold relay drive signal.	ON

## METER BUZZER

Test item	Operation	Description	Operation sound
METER BUZZER	Off	Stops buzzer output to the combination meter via CAN communication.	—
	On	Starts buzzer output to the combination meter via CAN communication.	—

## BRAKE ACTUATOR

**NOTE:**

The test can be performed only when the engine is running.

Test item	Operation	Description	"PRESS ORDER" value
BRAKE ACTUATOR 1	Off	Stops transmitting the brake fluid pressure control signal to end the test.	—
	On	Starts transmitting the brake fluid pressure control signal to start the test.	10 bar
BRAKE ACTUATOR 2	Off	Stops transmitting the brake fluid pressure control signal to end the test.	—
	On	Starts transmitting the brake fluid pressure control signal to start the test.	20 bar
BRAKE ACTUATOR 3	Off	Stops transmitting the brake fluid pressure control signal to end the test.	—
	On	Starts transmitting the brake fluid pressure control signal to start the test.	30 bar

**NOTE:**

The test is finished 10 seconds after starting.

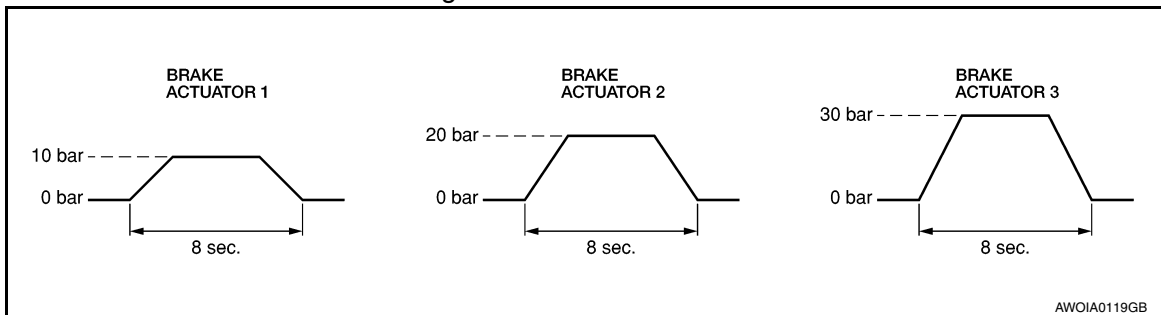

## ECU IDENTIFICATION

Displays ADAS control unit part number.

DAS

# ADAS CONTROL UNIT

< ECU DIAGNOSIS INFORMATION >

[ADAS CONTROL UNIT]

## ECU DIAGNOSIS INFORMATION

### ADAS CONTROL UNIT

#### Reference Value

INFOID:0000000011953064

#### VALUES ON THE DIAGNOSIS TOOL

**NOTE:**

The following table includes information (items) inapplicable to this vehicle. For information (items) applicable to this vehicle, refer to CONSULT display items.

Monitor item	Condition		Value/Status
MAIN SW	Ignition switch ON	When MAIN (ON/OFF) switch is pressed.	On
		When MAIN (ON/OFF) switch is not pressed.	Off
SET/COAST SW	Ignition switch ON	When SET/COAST switch is pressed.	On
		When SET/COAST switch is not pressed.	Off
CANCEL SW	Ignition switch ON	When CANCEL switch is pressed.	On
		When CANCEL switch is not pressed.	Off
RESUME/ACC SW	Ignition switch ON	When RESUME/ACCELERATE switch is pressed.	On
		When RESUME/ACCELERATE switch is not pressed.	Off
DISTANCE SW	Ignition switch ON	When DISTANCE switch is pressed.	On
		When DISTANCE switch is not pressed.	Off
CRUISE OPE	Drive the vehicle and activate the ICC system	When ICC system is controlling.	On
		When ICC system is not controlling.	Off
BRAKE SW	Ignition switch ON	When brake or clutch pedal is depressed.	Off
		When brake or clutch pedal is not depressed.	On
STOP LAMP SW	Ignition switch ON	When brake pedal is depressed.	On
		When brake pedal is not depressed.	Off
IDLE SW	Engine running	Idling	On
		Except idling (depress accelerator pedal)	Off
SET DISTANCE	<ul style="list-style-type: none"> <li>• Start the engine and turn the ICC system ON</li> <li>• Press the DISTANCE switch to change the ICC system</li> </ul>	When set to "long"	Long
		When set to "middle"	Mid
		When set to "short"	Short
CRUISE LAMP	Start the engine and press MAIN switch	ICC system ON (MAIN switch indicator ON).	On
		ICC system OFF (MAIN switch indicator OFF).	Off
OWN VHCL	<b>NOTE:</b> The item is indicated, but not monitored		Off
VHCL AHEAD	Drive the vehicle and activate the ICC system	When a vehicle ahead is detected (vehicle ahead detection indicator ON).	On
		When a vehicle ahead is not detected (vehicle ahead detection indicator OFF).	Off
ICC WARNING	Start the engine and press MAIN switch	When ICC system is malfunctioning (ICC system malfunction ON).	On
		When ICC system is normal (ICC system malfunction OFF).	Off



# ADAS CONTROL UNIT

< ECU DIAGNOSIS INFORMATION >

[ADAS CONTROL UNIT]

Monitor item	Condition	Value/Status
VHCL SPEED SE	While driving	Displays the vehicle speed calculated by ADAS control unit
SET VHCL SPD	While driving	When vehicle speed is set. Displays the set vehicle speed
BUZZER O/P	Engine running	When the buzzer of the following system operates: • ICC system • PFCW system • FEB system On
		When the buzzer of the following system does not operate: • ICC system • PFCW system • FEB system Off
THRTL SENSOR	<b>NOTE:</b> The item is indicated, but not monitored.	0.0
ENGINE RPM	Engine running	Equivalent to tachometer reading
WIPER SW	Ignition switch ON	Wiper not operating. Off
		Wiper LO operation. Low
		Wiper HI operation. High
YAW RATE	<b>NOTE:</b> The item is indicated, but not monitored.	0.0
BA WARNING	Engine running	FEB OFF indicator lamp ON. • When FEB system is malfunctioning. • When FEB system is turned to OFF. On
		FEB OFF indicator lamp OFF. • When FEB system is normal. • When FEB system is turned to ON. Off
STP LMP DRIVE	Drive the vehicle and activate the ICC system	When ICC brake hold relay is activated. On
		When ICC brake hold relay is not activated. Off
D POSITION SW	Engine running	When the shift selector is in "D" position or manual mode. On
		When the shift selector is in any position other than "D" or manual mode. Off
NP RANGE SW	Engine running	When the shift selector is in "N" or "P" position. On
		When the shift selector is in any position other than "N" or "P". Off
PKB SW	Ignition switch ON	When the parking brake is applied. On
		When the parking brake is released. Off
PWR SUP MONI	Engine running	Power supply voltage value of ADAS control unit
VHCL SPD AT	While driving	Value of CVT vehicle speed sensor signal
THRTL OPENING	Engine running	Depress accelerator pedal. Displays the throttle position
GEAR	While driving	Displays the gear position

A  
B  
C  
D  
E  
F  
G  
H  
I  
J  
K  
L  
M  
N  
P

DAS

# ADAS CONTROL UNIT

< ECU DIAGNOSIS INFORMATION >

[ADAS CONTROL UNIT]

Monitor item	Condition		Value/Status
CLUTCH SW SIG	Ignition switch ON	When clutch or brake pedal is depressed.	On
		When clutch or brake pedal is not depressed.	Off
NP SW SIG	Ignition switch ON	When the shift selector is in neutral position.	On
		When the shift selector is in any position other than neutral.	Off
MODE SIG	Start the engine and press MAIN switch	When ICC system is deactivated.	Off
		When ICC system is activated.	ICC
SET DISP IND	Press SET/COAST switch	SET switch indicator ON.	On
		SET switch indicator OFF.	Off
DISTANCE	Drive the vehicle and activate the ICC system	When a vehicle ahead is detected.	Displays the distance from the preceding vehicle
		When a vehicle ahead is not detected.	0.0
RELATIVE SPD	Drive the vehicle and activate the ICC system	When a vehicle ahead is detected.	Displays the relative speed.
		When a vehicle ahead is not detected.	0.0
ON ROOT GUIDE	<b>NOTE:</b> The item is indicated, but not monitored.		Off
FCW SYSTEM ON	Ignition switch ON	When the PFCW system is ON.	On
		When the PFCW system is OFF.	Off
Shift position	<ul style="list-style-type: none"> <li>• Engine running</li> <li>• While driving</li> </ul>		Displays the shift selector position
Turn signal	Turn signal lamps OFF.		Off
	Turn signal lamp LH blinking.		LH
	Turn signal lamp RH blinking.		RH
	Turn signal lamp LH and RH blinking.		LH&RH
SIDE G	While driving	Vehicle turning right.	Negative value
		Vehicle turning left.	Positive value
FUNC ITEM	Ignition switch ON		FUNC3
FUNC ITEM (FCW)	Engine running		On
FUNC ITEM (BSW)	Engine running		On
FUNC ITEM (NV-ICC)	<b>NOTE:</b> The item is indicated, but not monitored		Off
FCW SELECT	Ignition switch ON	"Forward Emergency Braking" set when the integral switch is ON.	On
		"Forward Emergency Braking" set when the integral switch is OFF.	Off
BSW SELECT	Ignition switch ON	"Blind Spot Warning" set when the integral switch is ON.	On
		"Blind Spot Warning" set when the integral switch is OFF.	Off
NAVI ICC SELECT	<b>NOTE:</b> The item is indicated, but not monitored.		Off
SYS SELECTABILITY	Ignition switch ON	Items set with the integral switch can be switched normally.	On
		Items set with the integral switch cannot be switched normally.	Off

# ADAS CONTROL UNIT

< ECU DIAGNOSIS INFORMATION >

[ADAS CONTROL UNIT]

Monitor item	Condition		Value/Status
BSW WARN LMP	Engine running	When the BSW system is malfunctioning.	On
		When the BSW system is normal.	Off
BSW SYSTEM ON	Ignition switch ON	When the BSW system is ON.	On
		When the BSW system is OFF.	Off
FCW SYSTEM ON	Engine running	When the FEB/PFCW system is ON.	On
		When the FEB/PFCW system is OFF.	Off
BATTERY CIRCUIT OFF	<b>NOTE:</b> The item is indicated, but not used.		Off
SYSTEM CANCEL MESSAGE	Engine running	System cancel display ON.	On
		System cancel display OFF.	Off
BSW ON INDICATOR	Engine running	BSW system display ON.	On
		BSW system display OFF.	Off
SIDE RADAR BLOCK COND	Engine running	Front bumper or side radar is dirty.	On
		Front bumper and side radar are clean.	Off
BSW IND BRIGHTNESS	Ignition switch ON	BSW system OFF.	Nothing
		Blind Spot Warning indicator brightness bright.	Bright
		Blind Spot Warning indicator brightness normal.	Normal
		Blind Spot Warning indicator brightness dark.	Dark
SL MAIN SW	Engine running	When speed limiter MAIN switch is pressed.	On
		When speed limiter MAIN switch is not pressed.	Off
FUNC ITEM (FEB)	Engine running		On
FEB SELECT	Ignition switch ON	"Forward Emergency Braking" set when the integral switch is ON.	On
		"Forward Emergency Braking" set when the integral switch is OFF.	Off
FEB SW	Engine running	FEB system ON.	On
		FEB system OFF.	Off
SL TARGET VEHICLE SPEED	While driving	When vehicle speed is set.	Displays the set vehicle speed
SL SET LAMP	<ul style="list-style-type: none"> <li>• Drive the vehicle and activate the speed limiter</li> <li>• Press speed limiter MAIN switch</li> </ul>	Speed limiter SET indicator ON.	On
		Speed limiter SET indicator OFF.	Off
SL LIMIT LAMP	<ul style="list-style-type: none"> <li>• Drive the vehicle and activate the speed limiter</li> <li>• Press speed limiter MAIN switch</li> </ul>	Speed limiter system ON.	On
		Speed limiter system OFF.	Off
ASCDCANCEL (LOW SPEED)	Drive the vehicle and activate the ASCD	ASCDCancelled by low vehicle speed.	On
		Other than above.	Off
ASCDCANCEL (SPEED DIFF)	Drive the vehicle and activate the ASCD	ASCDCancelled by difference between set speed and vehicle speed.	On
		Other than above.	Off
KICK DOWN	Drive the vehicle and activate the speed limiter	When accelerator pedal is fully depressed.	On
		Other than above.	Off

A  
B  
C  
D  
E  
F  
G  
H  
I  
J  
K  
L  
M  
N  
P

DAS

# ADAS CONTROL UNIT

< ECU DIAGNOSIS INFORMATION >

[ADAS CONTROL UNIT]

TERMINAL LAYOUT

PHYSICAL VALUES

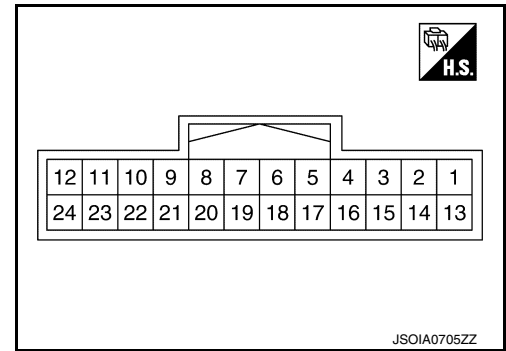

Terminal No. (Wire color)		Description		Condition		Value (Approx.)
+	-	Signal name	Input/ Output			
1 (B)	Ground	Ground	Input	—		0 V
2 (L)		ITS communication high	—	—		—
3 (BG)		Ignition power supply	Input	Ignition switch ON		Battery voltage
5 (Y)		ITS communication low	—	—		—
9 (L)		CAN high	—	—		—
10 (P)		CAN low	—	—		—
14 (W)		ICC brake hold relay drive signal	Output	Ignition switch ON	—	

## Fail-safe (ADAS Control Unit)

INFOID:0000000011953065

If a malfunction occurs in each system, ADAS control unit cancels each control, sounds a beep, and turns ON the warning or indicator lamp.

System	Buzzer	Warning lamp/Warning display	Description
Intelligent Cruise Control (ICC)	High-pitched tone	ICC system warning	Cancel
Forward Emergency Braking (FEB)	High-pitched tone	FEB warning lamp (Yellow)	Cancel
Predictive Forward Collision Warning (PFCW)	High-pitched tone	FEB warning lamp (Yellow)	Cancel
Blind Spot Warning (BSW)	Low-pitched tone	BSW system warning	Cancel
Rear Cross Traffic Alert (RCTA)	—	BSW system warning	Cancel

## DTC Inspection Priority Chart

INFOID:0000000011953066

If multiple DTCs are detected simultaneously, check them one by one depending on the following DTC inspection priority chart.

# ADAS CONTROL UNIT

< ECU DIAGNOSIS INFORMATION >

[ADAS CONTROL UNIT]

Priority	Detected items (DTC)
1	<ul style="list-style-type: none"> <li>• U1507: LOST COMM (SIDE RDR R)</li> <li>• U1508: LOST COMM (SIDE RDR L)</li> </ul>
2	<ul style="list-style-type: none"> <li>• U1000: CAN COMM CIRCUIT</li> <li>• U1321: CONFIGURATION</li> </ul>
3	<ul style="list-style-type: none"> <li>• C1A17: ICC SENSOR MALF</li> <li>• C1B53: SIDE RDR R MALF</li> <li>• C1B54: SIDE RDR L MALF</li> </ul>
4	<ul style="list-style-type: none"> <li>• C1A01: POWER SUPPLY CIR</li> <li>• C1A02: POWER SUPPLY CIR 2</li> <li>• C1A13: STOP LAMP RLY FIX</li> <li>• C1A14: ECM CIRCUIT</li> <li>• C1A34: COMMAND ERROR</li> <li>• U0121: VDC CAN CIR 2</li> <li>• U0235: ICC SENSOR CAN CIR 1</li> <li>• U0401: ECM CAN CIR 1</li> <li>• U0402: TCM CAN CIR 1</li> <li>• U0415: VDC CAN CIR 1</li> <li>• U0433: ICC SENSOR CAN CIR 2</li> <li>• U1503: SIDE RDR L CAN CIR 2</li> <li>• U1504: SIDE RDR L CAN CIR 1</li> <li>• U1505: SIDE RDR R CAN CIR 2</li> <li>• U1506: SIDE RDR R CAN CIR 1</li> </ul>
5	<ul style="list-style-type: none"> <li>• C1A03: VHCL SPEED SE CIRC</li> </ul>
6	<ul style="list-style-type: none"> <li>• C1A00: CONTROL UNIT</li> </ul>

## DTC Index

INFOID:000000011953067

### Systems for fail-safe

- A: Intelligent Cruise Control (ICC)
- B: Forward Emergency Braking (FEB)
- C: Predictive Forward Collision Warning (PFCW)
- D: Blind Spot Warning (BSW)
- E: Rear Cross Traffic Alert (RCTA)

DTC	CONSULT display	Fail-safe System	Reference
CONSULT			
NO DTC IS DETECTED. FURTHER TESTING MAY BE REQUIRED	NO DTC IS DETECTED. FURTHER TESTING MAY BE REQUIRED	—	—
U1507	LOST COMM (SIDE RDR R)	D, E	<a href="#">DAS-76</a>
U1508	LOST COMM (SIDE RDR L)	D, E	<a href="#">DAS-77</a>
U1000 <sup>NOTE</sup>	CAN COMM CIRCUIT	A, B, C, D, E	<a href="#">DAS-65</a>
U1321	CONFIGURATION	A, B, C, D, E	<a href="#">DAS-67</a>
C1A17	ICC SENSOR MALF	A, B, C	<a href="#">DAS-51</a>
C1B53	SIDE RDR R MALF	D, E	<a href="#">DAS-53</a>
C1B54	SIDE RDR L MALF	D, E	<a href="#">DAS-54</a>
C1A01	POWER SUPPLY CIR	A, B, C, D, E	<a href="#">DAS-40</a>
C1A02	POWER SUPPLY CIR 2	A, B, C, D, E	<a href="#">DAS-40</a>
C1A13	STOP LAMP RLY FIX	A, B, C	<a href="#">DAS-43</a>
C1A14	ECM CIRCUIT	A, B, C	<a href="#">DAS-49</a>
C1A34	COMMAND ERROR	A, B, C	<a href="#">DAS-52</a>
U0121	VDC CAN CIR 2	A, B, C, D, E	<a href="#">DAS-55</a>

# ADAS CONTROL UNIT

< ECU DIAGNOSIS INFORMATION >

[ADAS CONTROL UNIT]

Systems for fail-safe

- A: Intelligent Cruise Control (ICC)
- B: Forward Emergency Braking (FEB)
- C: Predictive Forward Collision Warning (PFCW)
- D: Blind Spot Warning (BSW)
- E: Rear Cross Traffic Alert (RCTA)

DTC	CONSULT display	Fail-safe System	Reference
U0235	ICC SENSOR CAN CIRC 1	A, C, D, E	<a href="#">DAS-57</a>
U0401	ECM CAN CIR 1	A, B, C, D, E	<a href="#">DAS-58</a>
U0402	TCM CAN CIR 1	A, B, C, D, E	<a href="#">DAS-60</a>
U0415	VDC CAN CIR 1	A, B, C, D, E	<a href="#">DAS-62</a>
U0433	ICC SENSOR CAN CIRC 2	A, B, C	<a href="#">DAS-64</a>
U1503	SIDE RDR L CAN CIR 2	D, E	<a href="#">DAS-68</a>
U1504	SIDE RDR L CAN CIR 1	D, E	<a href="#">DAS-70</a>
U1505	SIDE RDR R CAN CIR 2	D, E	<a href="#">DAS-72</a>
U1506	SIDE RDR R CAN CIR 1	D, E	<a href="#">DAS-74</a>
C1A03	VHCL SPEED SE CIRC	D, E	<a href="#">DAS-41</a>
C1A00	CONTROL UNIT	A, B, C, D, E	<a href="#">DAS-39</a>

**NOTE:**

With the detection of "U1000" some systems do not perform the fail-safe operation.

A system controlling based on a signal received from the control unit performs fail-safe operation when the communication with the ADAS control unit becomes inoperable.

# WIRING DIAGRAM

## DRIVER ASSISTANCE SYSTEMS

### Wiring Diagram

INFOID:000000011953068

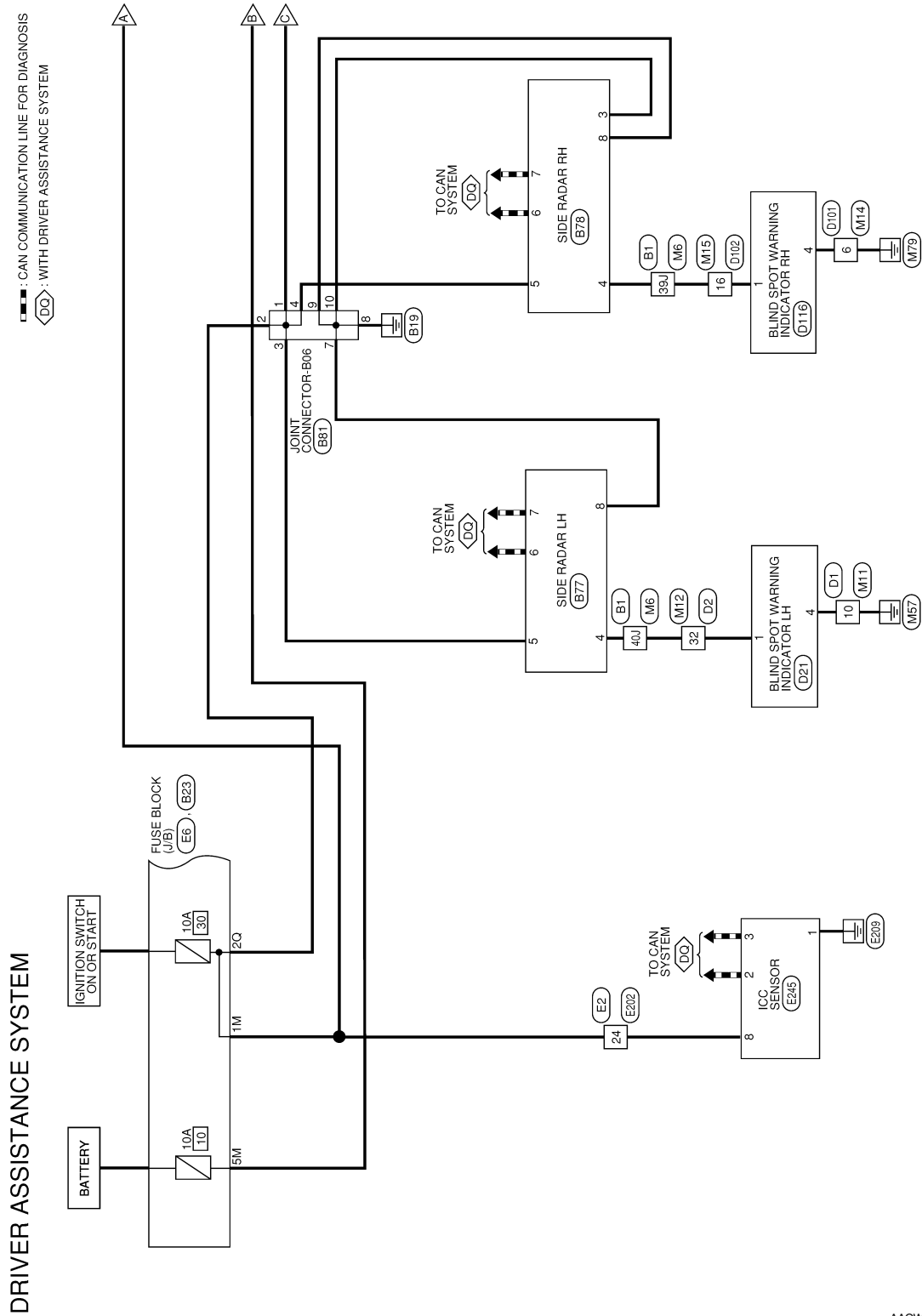

A  
B  
C  
D  
E  
F  
G  
H  
I  
J  
K  
L  
M  
N  
P

DAS

# DRIVER ASSISTANCE SYSTEMS

< WIRING DIAGRAM >

[ADAS CONTROL UNIT]

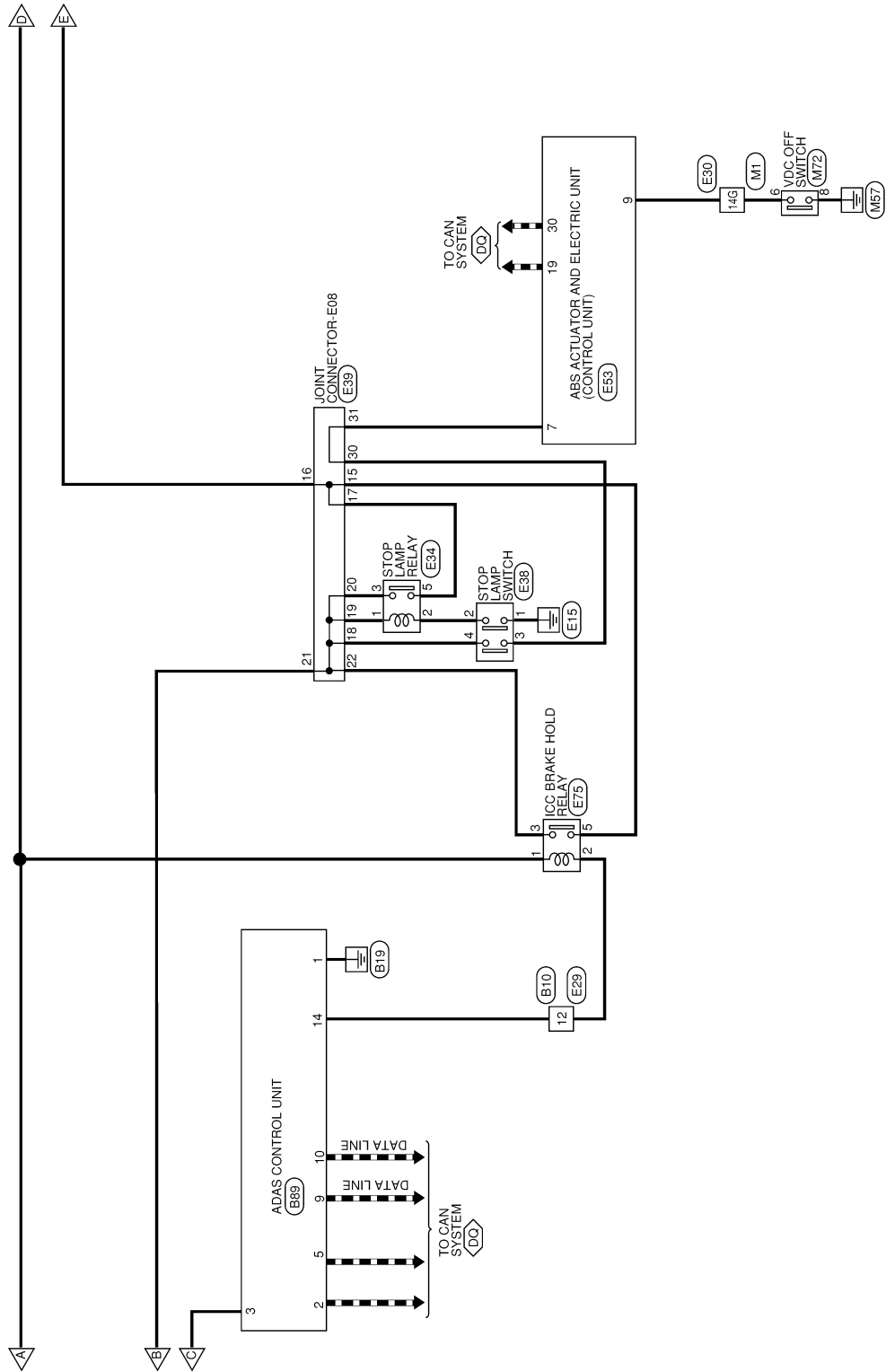

AAOWA0106GB



# DRIVER ASSISTANCE SYSTEMS

< WIRING DIAGRAM >

[ADAS CONTROL UNIT]

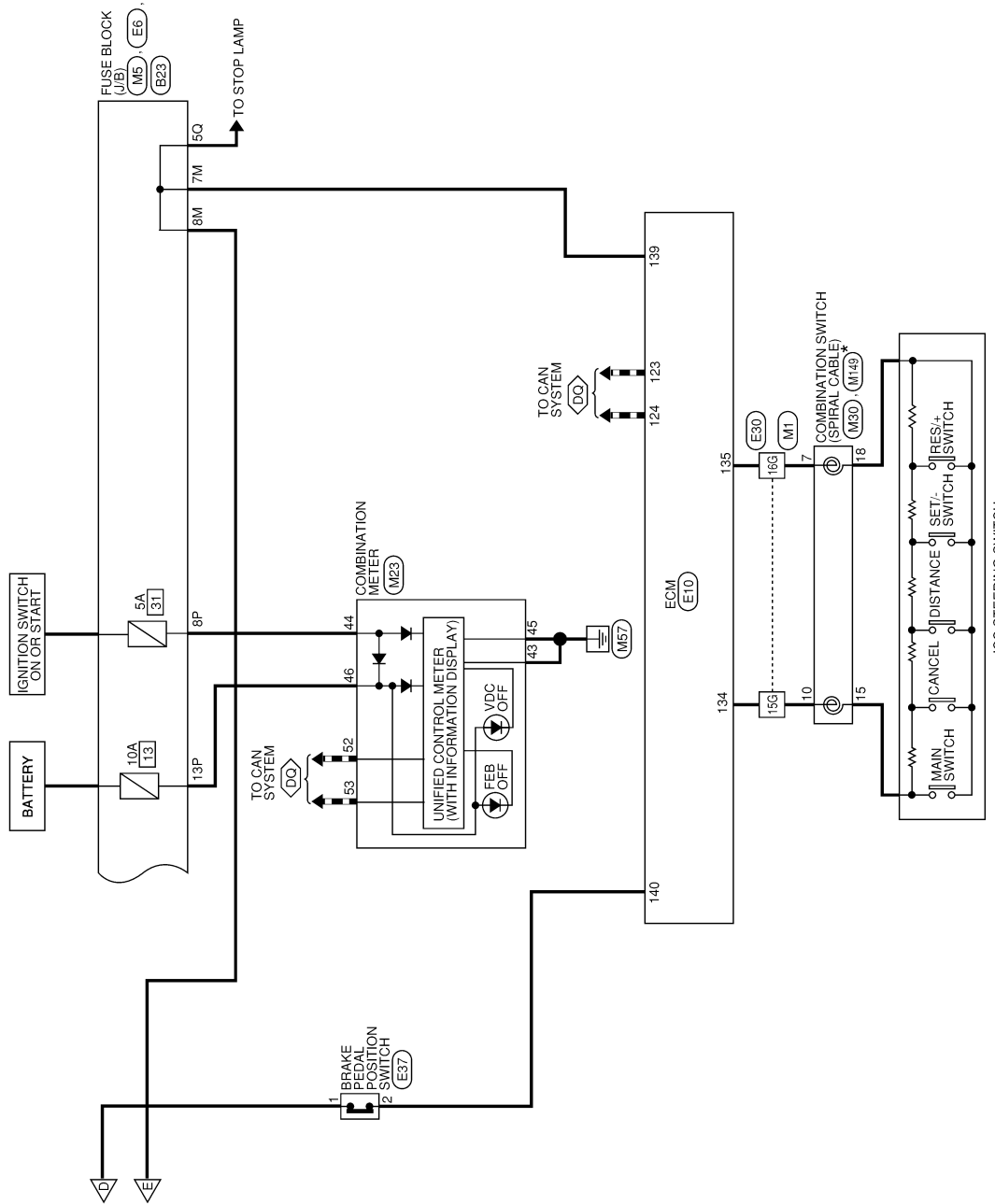

\*: This connector is not shown in "Harness Layout"

A  
B  
C  
D  
E  
F  
G  
H  
I  
J  
K  
L  
M  
N  
P

DAS

AAOWA0107GB

# DRIVER ASSISTANCE SYSTEMS

< WIRING DIAGRAM >

[ADAS CONTROL UNIT]

## DRIVER ASSISTANCE SYSTEM CONNECTORS

Connector No.	M1
Connector Name	WIRE TO WIRE
Connector Type	TH80FW-CST16-TM4
Connector Color	WHITE

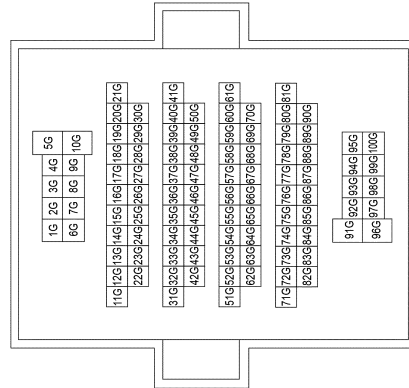

Terminal No.	Color of Wire	Signal Name
14G	LG	-
15G	BG	-
16G	R	-

Connector No.	M5
Connector Name	FUSE BLOCK (J/B)
Connector Type	NS16FW-CS
Connector Color	WHITE



Terminal No.	Color of Wire	Signal Name
8P	BR	-
13P	G	-

Connector No.	M6
Connector Name	WIRE TO WIRE
Connector Type	TH80FDGY-CST16-TM4
Connector Color	GRAY

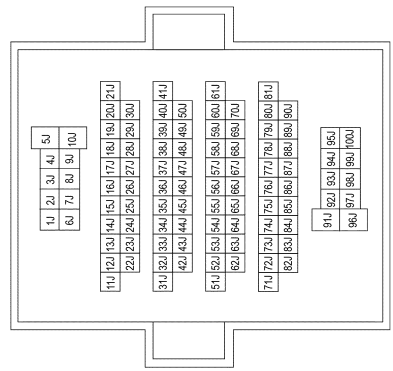

Terminal No.	Color of Wire	Signal Name
38J	P	-
40J	W	-

Connector No.	M11
Connector Name	WIRE TO WIRE
Connector Type	NS16MW-CS
Connector Color	WHITE

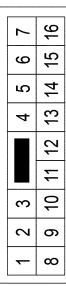

Terminal No.	Color of Wire	Signal Name
10	B	-

Connector No.	M12
Connector Name	WIRE TO WIRE
Connector Type	TH40MW-NH
Connector Color	WHITE

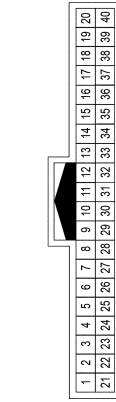

Terminal No.	Color of Wire	Signal Name
32	W	-

Connector No.	M14
Connector Name	WIRE TO WIRE
Connector Type	NS10MW-CS
Connector Color	WHITE

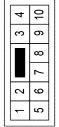

Terminal No.	Color of Wire	Signal Name
6	GR	-

Connector No.	M15
Connector Name	WIRE TO WIRE
Connector Type	TH24MW-NH
Connector Color	WHITE



Terminal No.	Color of Wire	Signal Name
16	P	-

# DRIVER ASSISTANCE SYSTEMS

< WIRING DIAGRAM >

[ADAS CONTROL UNIT]

Connector No.	E6
Connector Name	FUSE BLOCK (J/B)
Connector Type	NS10FW-CS
Connector Color	WHITE



4M	3M	2M	1M
10M	9M	8M	7M
6M	5M		

Terminal No.	Color of Wire	Signal Name
1M	BG	-
5M	P	-
7M	GR	-
8M	W	-

Connector No.	E10
Connector Name	ECM
Connector Type	RH24FB-RZ8-L-LH
Connector Color	BLACK



121	125	129	133	137	141	145	149
122	126	130	134	138	142	146	150
123	127	131	135	139	143	147	151
124	128	132	136	140	144	148	152

Terminal No.	Color of Wire	Signal Name
123	P	CAN-L
124	L	CAN-H
134	G	ASCD/CC STEERING SWITCH
135	R	ASCD/CC STEERING SWITCH GROUND
139	GR	STOP LAMP SWITCH
140	BR	BRAKE PEDAL POSITION SWITCH

Connector No.	M72
Connector Name	VDC OFF SWITCH
Connector Type	TH08FB-NH
Connector Color	BLACK



4	3	2	1
8	7	6	5

Terminal No.	Color of Wire	Signal Name
6	LG	-
8	B	-

Connector No.	M149
Connector Name	COMBINATION SWITCH (SPIRAL CABLE)
Connector Type	TK08FGY-X
Connector Color	GRAY



22	21	20	19	18	17	16	15
----	----	----	----	----	----	----	----

Terminal No.	Color of Wire	Signal Name
15	W	-
18	BR	-

Connector No.	E2
Connector Name	WIRE TO WIRE
Connector Type	TH24MW-NH
Connector Color	WHITE



1	2	3	4	5	6	7	8	9	10	11	12
13	14	15	16	17	18	19	20	21	22	23	24

Terminal No.	Color of Wire	Signal Name
24	BG	-

Connector No.	M23
Connector Name	COMBINATION METER
Connector Type	TH16FW-NH
Connector Color	WHITE



41	42	43	44	45	46	47	48
49	50	51	52	53	54	55	56

Terminal No.	Color of Wire	Signal Name
43	B	GND1
44	BR	POWER (IGN)
45	B	GND2
46	G	POWER (BAT)
52	P	CAN-L
53	L	CAN-H

Connector No.	M30
Connector Name	COMBINATION SWITCH (SPIRAL CABLE)
Connector Type	TK08FGY-1V
Connector Color	GRAY



10	9	8	7
14	13	12	11

Terminal No.	Color of Wire	Signal Name
7	R	-
10	BG	-

AAOIA0364GB

A  
B  
C  
D  
E  
F  
G  
H  
I  
J  
K  
L  
M  
N  
P

DAS

# DRIVER ASSISTANCE SYSTEMS

< WIRING DIAGRAM >

[ADAS CONTROL UNIT]

Connector No.	E39
Connector Name	JOINT CONNECTOR-E08
Connector Type	BJ30FW
Connector Color	WHITE

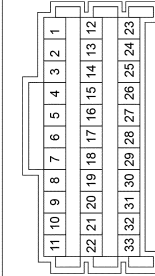

Terminal No.	Color of Wire	Signal Name
15	W	-
16	W	-
17	W	-
18	P	-
19	P	-
20	P	-
21	P	-
22	P	-
30	LG	-
31	LG	-

Connector No.	E53
Connector Name	ABS ACTUATOR AND ELECTRIC UNIT (CONTROL UNIT) (WITH INTELLIGENT CRUISE CONTROL SYSTEM)
Connector Type	SAZ34FB-HS2-SJZZ-UH
Connector Color	BLACK

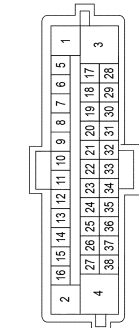

Terminal No.	Color of Wire	Signal Name
7	LG	BLS
9	V	VDC OFF
19	L	CAN-H
30	P	CAN-L

Connector No.	E34
Connector Name	STOP LAMP RELAY
Connector Type	MS02FL-M2-LC
Connector Color	BLUE

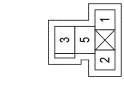

Terminal No.	Color of Wire	Signal Name
1	P	-
2	R	-
3	P	-
5	W	-

Connector No.	E37
Connector Name	BRAKE PEDAL POSITION SWITCH
Connector Type	M02FBR-LC
Connector Color	BROWN



Terminal No.	Color of Wire	Signal Name
1	BG	-
2	BR	-

Connector No.	E38
Connector Name	STOP LAMP SWITCH
Connector Type	M04FW-LC
Connector Color	WHITE

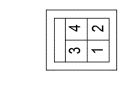

Terminal No.	Color of Wire	Signal Name
1	B	-

Connector No.	E29
Connector Name	WIRES TO WIRE
Connector Type	NS16FW-CS
Connector Color	WHITE

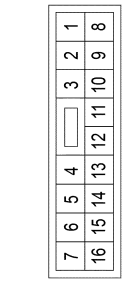

Terminal No.	Color of Wire	Signal Name
12	W	-

Connector No.	E30
Connector Name	WIRES TO WIRE
Connector Type	TH80MW-CS116-TM4
Connector Color	WHITE

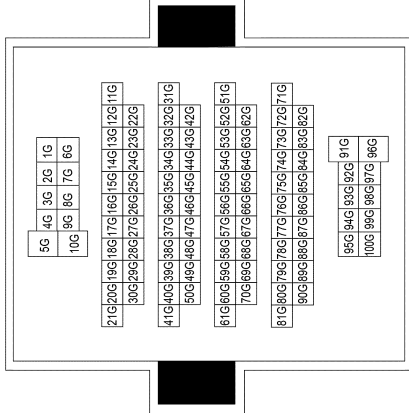

Terminal No.	Color of Wire	Signal Name
14G	V	-
15G	G	-
16G	R	-

AAOIA00365GB

# DRIVER ASSISTANCE SYSTEMS

< WIRING DIAGRAM >

[ADAS CONTROL UNIT]

Connector No.	B23
Connector Name	FUSE BLOCK (J/B)
Connector Type	NS08FW-CS
Connector Color	WHITE

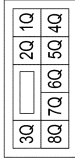

Terminal No.	Color of Wire	Signal Name
2Q	BG	-
5Q	L	-

Connector No.	B77
Connector Name	SIDE RADAR LH
Connector Type	JAD08FB-5P
Connector Color	BLACK

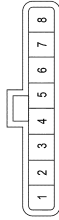

Terminal No.	Color of Wire	Signal Name
4	W	-
5	O	-
6	L	-
7	Y	-
8	B	-

3	Y	ITS CAN-L
8	BG	IGN

Connector No.	B1
Connector Name	WIRE TO WIRE
Connector Type	TH80MDGY-CS16-TM4
Connector Color	GRAY

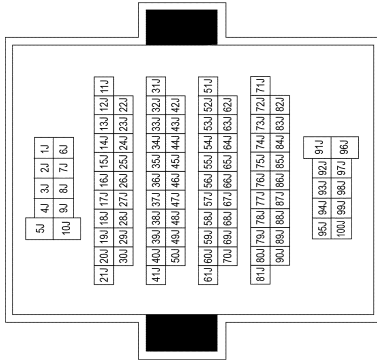

Terminal No.	Color of Wire	Signal Name
38J	P	-
40J	W	-

Connector No.	B10
Connector Name	WIRE TO WIRE
Connector Type	NS16MW-CS
Connector Color	WHITE

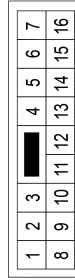

Terminal No.	Color of Wire	Signal Name
12	W	-

Connector No.	E75
Connector Name	ICC BRAKE HOLD RELAY
Connector Type	MS02FL-M2-LC
Connector Color	BLUE



Terminal No.	Color of Wire	Signal Name
1	BG	-
2	W	-
3	P	-
5	W	-

Connector No.	E202
Connector Name	WIRE TO WIRE
Connector Type	TH24FW-NH
Connector Color	WHITE

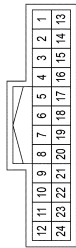

Terminal No.	Color of Wire	Signal Name
24	BG	-

Connector No.	E245
Connector Name	ICC SENSOR
Connector Type	AAZ08FB
Connector Color	BLACK

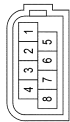

Terminal No.	Color of Wire	Signal Name
1	GR	GND
2	L	ITS CAN-H

AAOIA0366GB

A  
B  
C  
D  
E  
F  
G  
H  
I  
J  
K  
L  
M  
N  
P



# DRIVER ASSISTANCE SYSTEMS

< WIRING DIAGRAM >

[ADAS CONTROL UNIT]

Connector No.	D2
Connector Name	WIRE TO WIRE
Connector Type	TH40FW-NH
Connector Color	WHITE

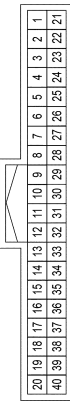
Terminal No.	Color of Wire	Signal Name
32	P	-

Connector No.	D21
Connector Name	BLIND SPOT WARNING INDICATOR LH
Connector Type	TH04MW-NH
Connector Color	WHITE

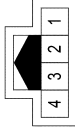

Terminal No.	Color of Wire	Signal Name
1	P	-
4	B	-

Connector No.	D101
Connector Name	WIRE TO WIRE
Connector Type	NS10FW-CS
Connector Color	WHITE

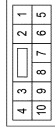
Terminal No.	Color of Wire	Signal Name
6	B	-

Connector No.	B89
Connector Name	ADAS CONTROL UNIT
Connector Type	TH24FW-NH
Connector Color	WHITE

Terminal No.	Color of Wire	Signal Name
1	B	GND
2	L	ITS CAN-H
3	BG	IGN
5	Y	ITS CAN-L
9	L	CAN-H
10	P	CAN-L
14	W	BRAKE RELAY

Connector No.	D1
Connector Name	WIRE TO WIRE
Connector Type	NS16FW-CS
Connector Color	WHITE

Terminal No.	Color of Wire	Signal Name
10	B	-

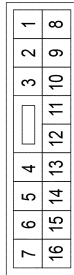
Connector No.	B78
Connector Name	SIDE RADAR RH
Connector Type	JAD08FB-6P
Connector Color	BLACK

Terminal No.	Color of Wire	Signal Name
3	B	-
4	P	-
5	O	-
6	L	-
7	Y	-
8	B	-

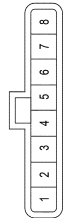
Connector No.	B81
Connector Name	JOINT CONNECTOR-B06
Connector Type	A12FL
Connector Color	BLUE

Terminal No.	Color of Wire	Signal Name
1	BG	-
2	BG	-
3	O	-
4	O	-
7	B	-
8	B	-
9	B	-
10	B	-

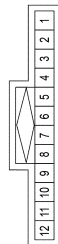
AAOIA0367GB

# DRIVER ASSISTANCE SYSTEMS

< WIRING DIAGRAM >

[ADAS CONTROL UNIT]

A  
B  
C  
D  
E  
F  
G  
H  
I  
J  
K  
L  
M  
N  
P

Connector No.	D102
Connector Name	WIRE TO WIRE
Connector Type	TH24FW-NH
Connector Color	WHITE

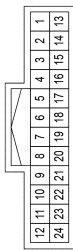

Terminal No.	16	Color of Wire	R	Signal Name	-
--------------	----	---------------	---	-------------	---

Connector No.	D116
Connector Name	BLIND SPOT WARNING INDICATOR RH
Connector Type	TH04MW-NH
Connector Color	WHITE

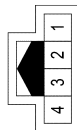

Terminal No.	1	Color of Wire	R	Signal Name	-
	4		B		-

DAS

AAOIA0368GB

## ADDITIONAL SERVICE WHEN REPLACING ADAS CONTROL UNIT

< BASIC INSPECTION >

[ADAS CONTROL UNIT]

### BASIC INSPECTION

#### ADDITIONAL SERVICE WHEN REPLACING ADAS CONTROL UNIT

##### Description

INFOID:0000000011953069

Always perform the ADAS control unit configuration after replacing the ADAS control unit.

##### Work Procedure

INFOID:0000000011953070

#### 1. ADAS CONTROL UNIT CONFIGURATION

##### ⓅCONSULT

Perform the ADAS control unit configuration. Refer to [DAS-37, "Description"](#).

>> GO TO 2.

#### 2. PERFORM SELF-DIAGNOSIS

##### ⓅCONSULT

1. Turn ignition switch ON.
2. Select "Self Diagnostic Result" mode of "ICC/ADAS".
3. Check DTC.

##### Is DTC detected?

- YES >> Perform the trouble diagnosis for the detected DTC. Refer to [DAS-25, "DTC Index"](#).  
NO >> Inspection End.



# CONFIGURATION (ADAS CONTROL UNIT)

< BASIC INSPECTION >

[ADAS CONTROL UNIT]

## CONFIGURATION (ADAS CONTROL UNIT)

### Description

INFOID:000000011953071

- Since vehicle specifications are not included in the ADAS control unit after replacement, it is required to write vehicle specifications using CONSULT.
- Configuration has three functions as follows:

Function		Description
Read/Write Configuration	Before ECU	Allows the reading of vehicle specification written in ADAS control unit to store the specification in CONSULT.
	After ECU replacement	Allows the writing of the vehicle information stored in CONSULT into the ADAS control unit.
Manual Configuration		Allows the writing of the vehicle specification into the ADAS control unit by hand.

### Work Procedure

INFOID:000000011953072

#### CAUTION:

- Use “Manual Configuration” only when “TYPE ID” of ADAS control unit cannot be read.
- If an error occurs during configuration, start over from the beginning.

#### 1. CHECKING TYPE ID (1)

Use FAST (service parts catalogue) to search ADAS control unit of the applicable vehicle and find “Type ID”.

Is “Type ID” displayed?

YES >> Print out “Type ID” and GO TO 2.

NO >> “Configuration” is not required for ADAS control unit. Replace in the usual manner. Refer to [DAS-80. "Removal and Installation"](#).

#### 2. CHECKING TYPE ID (2)

ⓂCONSULT Configuration

1. Select “Before Replace ECU” of “Read/Write Configuration”.
2. Check that “Type ID” is displayed on the CONSULT screen.

Is “Type ID” displayed?

YES >> GO TO 3.

NO >> GO TO 7.

#### 3. VERIFYING TYPE ID (1)

ⓂCONSULT Configuration

Compare a “Type ID” displayed on the CONSULT screen with the one searched by using FAST (service parts catalogue) to check that these “Type ID” agree with each other.

#### NOTE:

For the “Type ID” searched by using FAST (service parts catalog), use the last five digits of the “Type ID”.

>> GO TO 4.

#### 4. SAVING TYPE ID

ⓂCONSULT Configuration

Save “Type ID” on CONSULT.

>> GO TO 5.

#### 5. REPLACING ADAS CONTROL UNIT (1)

Replace ADAS control unit. Refer to [DAS-80. "Removal and Installation"](#).

>> GO TO 6.

#### 6. WRITING (AUTOMATIC WRITING)

A  
B  
C  
D  
E  
F  
G  
H  
I  
J  
K  
L  
M  
N  
P

DAS

## CONFIGURATION (ADAS CONTROL UNIT)

< BASIC INSPECTION >

[ADAS CONTROL UNIT]

### ⓑ CONSULT Configuration

1. Select "After Replace ECU" of "Re/programming, Configuration" or that of "Read / Write Configuration".
2. Select the "Type ID" agreeing with the one stored on CONSULT and the one searched by using FAST (service parts catalogue) to write the "Type ID" into the ADAS control unit.

**NOTE:**

For the "Type ID" searched by using FAST (service parts catalog), use the last five digits of the "Type ID".

>> GO TO 9.

### 7. REPLACING ADAS CONTROL UNIT (2)

Replace ADAS control unit. Refer to [DAS-80, "Removal and Installation"](#).

>> GO TO 8.

### 8. WRITING (MANUAL WRITING)

#### ⓑ CONSULT Configuration

1. Select "Manual Configuration".
2. Select the "Type ID" searched by using FAST (service parts catalogue) to write the "Type ID" into the ADAS control unit.

**NOTE:**

For the "Type ID" searched by using FAST (service parts catalog), use the last five digits of the "Type ID".

>> GO TO 9.

### 9. VERIFYING TYPE ID (2)

Compare "Type ID" written into the ADAS control unit with the one searched by using FAST (service parts catalogue) to check that these "Type ID" agree with each other.

**NOTE:**

For the "Type ID" searched by using FAST (service parts catalog), use the last five digits of the "Type ID".

>> GO TO 10.

### 10. RESTART ADAS BY IGN OFF/IGN ON

1. Turn the ignition switch OFF.
2. Turn the ignition switch ON.

>> GO TO 11.

### 11. PERFORMING SUPPLEMENTARY WORK

1. Perform "Self Diagnostic Result" of all systems.
2. Erase "Self Diagnostic Result".

>> End of work.

**DTC/CIRCUIT DIAGNOSIS**

C1A00 CONTROL UNIT

DTC Description

INFOID:0000000011953073

DTC DETECTION LOGIC

DTC No.	CONSULT screen terms (Trouble diagnosis content)	DTC detection condition	
C1A00	CONTROL UNIT (Control unit)	Diagnosis condition	When ignition switch is ON.
		Signal (terminal)	-
		Threshold	ADAS control unit internal malfunction
		Diagnosis delay time	-

POSSIBLE CAUSE

ADAS control unit

FAIL-SAFE

The following systems are canceled:

- Intelligent Cruise Control (ICC)
- Forward Emergency Braking (FEB)
- Predictive Forward Collision Warning (PFCW)
- Blind Spot Warning (BSW)
- Rear Cross Traffic Alert (RCTA)

DTC CONFIRMATION PROCEDURE

**1**.PERFORM DTC CONFIRMATION PROCEDURE

CONSULT

1. Start the engine.
2. Select "All DTC Reading" mode.
3. Check DTC.
4. Check if "C1A00" is detected as the current malfunction in "Self Diagnostic Result" mode of "ICC/ADAS".

Is "C1A00" detected as the current malfunction?

- YES >> Refer to [DAS-39, "Diagnosis Procedure"](#).
- NO-1 >> To check malfunction symptom before repair: Refer to [GI-41, "Intermittent Incident"](#).
- NO-2 >> Confirmation after repair: Inspection End.

Diagnosis Procedure

INFOID:0000000011953074

**1**.CHECK SELF DIAGNOSTIC RESULT

Check if any DTC other than "C1A00" is detected in "Self Diagnostic Result" mode of "ICC/ADAS".

Is any DTC detected?

- YES >> Perform diagnosis on the detected DTC and repair or replace the malfunctioning parts. Refer to [DAS-25, "DTC Index"](#).
- NO >> Replace the ADAS control unit. Refer to [DAS-80, "Removal and Installation"](#).

DAS

# C1A01 POWER SUPPLY CIRCUIT 1, C1A02 POWER SUPPLY CIRCUIT 2

< DTC/CIRCUIT DIAGNOSIS >

[ADAS CONTROL UNIT]

## C1A01 POWER SUPPLY CIRCUIT 1, C1A02 POWER SUPPLY CIRCUIT 2

### DTC Description

INFOID:000000011953075

### DTC DETECTION LOGIC

DTC No.	CONSULT screen terms (Trouble diagnosis content)	DTC detection condition		
C1A01	POWER SUPPLY CIR (Power supply circuit)	1	Diagnosis condition	When ignition switch is ON.
			Signal (terminal)	-
			Threshold	Less than 7.9 V
			Diagnosis delay time	5 seconds or more
C1A02	POWER SUPPLY CIR 2 (Power supply circuit 2)	2	Diagnosis condition	When ignition switch is ON.
			Signal (terminal)	-
			Threshold	More than 19.3 V
			Diagnosis delay time	5 seconds or more

### POSSIBLE CAUSE

- Connector, harness or fuse
- ADAS control unit

### FAIL-SAFE

The following systems are canceled:

- Intelligent Cruise Control (ICC)
- Forward Emergency Braking (FEB)
- Predictive Forward Collision Warning (PFCW)
- Blind Spot Warning (BSW)
- Rear Cross Traffic Alert (RCTA)

### DTC CONFIRMATION PROCEDURE

#### 1.PERFORM DTC CONFIRMATION PROCEDURE

##### CONSULT

1. Start the engine.
2. Turn the MAIN switch of ICC system ON.
3. Select "All DTC Reading" mode.
4. Check if "C1A01" or "C1A02" is detected as the current malfunction in "Self Diagnostic Result" mode of "ICC/ADAS".

Is "C1A01" or "C1A02" detected as the current malfunction?

YES >> Refer to [DAS-40. "Diagnosis Procedure"](#).

NO-1 >> To check malfunction symptom before repair: Refer to [GI-41. "Intermittent Incident"](#).

NO-2 >> Confirmation after repair: Inspection End.

### Diagnosis Procedure

INFOID:000000011953076

#### 1.CHECK ADAS CONTROL UNIT POWER SUPPLY AND GROUND CIRCUIT

Check power supply and ground circuit of ADAS control unit. Refer to [DAS-79. "Diagnosis Procedure"](#).

Is the inspection result normal?

YES >> Replace the ADAS control unit. Refer to [DAS-80. "Removal and Installation"](#).

NO >> Repair or replace the malfunctioning parts.

# C1A03 VEHICLE SPEED SENSOR

< DTC/CIRCUIT DIAGNOSIS >

[ADAS CONTROL UNIT]

## C1A03 VEHICLE SPEED SENSOR

### DTC Description

INFOID:0000000011953077

### DTC DETECTION LOGIC

DTC No.	CONSULT screen terms (Trouble diagnosis content)	DTC detection condition	
C1A03	VHCL SPEED SE CIRC (Vehicle speed sensor circuit)	Diagnosis condition	When Ignition switch is ON.
		Signal (terminal)	–
		Threshold	If the vehicle speed is greater than 19 mph (30km/h) 0.3s and vehicle speed drops to less than 1.8 mph (3km/h) within 200ms and vehicle speed is less than 3km/h continues for 3s.
		Diagnosis delay time	–

### POSSIBLE CAUSE

- Wheel speed sensor
- ABS actuator and electric unit (control unit)
- ADAS control unit

### FAIL-SAFE

The following systems are canceled:

- Blind Spot Warning (BSW)
- Rear Cross Traffic Alert (RCTA)

### DTC CONFIRMATION PROCEDURE

#### 1. CHECK DTC PRIORITY

If DTC “C1A03” is displayed with DTC “U1000”, first diagnose the DTC “U1000”.

#### Is applicable DTC detected?

- YES >> Perform diagnosis of applicable.
- U1000: Refer to [DAS-65, "DTC Description"](#).
- NO >> GO TO 2.

#### 2. PERFORM DTC CONFIRMATION PROCEDURE

#### ⓂCONSULT

1. Start the engine.
2. Turn the MAIN switch of ICC system ON.
3. Drive the vehicle at 19 mph (30 km/h) or more.  
**CAUTION:**  
**Always drive safely.**
4. Stop the vehicle.
5. Select “All DTC Reading” mode.
6. Check if “C1A03” is detected as the current malfunction in “Self Diagnostic Result” mode of “ICC/ADAS”.

#### Is “C1A03” detected as the current malfunction?

- YES >> Refer to [DAS-41, "Diagnosis Procedure"](#).
- NO-1 >> To check malfunction symptom before repair: Refer to [GI-41, "Intermittent Incident"](#).
- NO-2 >> Confirmation after repair: Inspection End.

### Diagnosis Procedure

INFOID:0000000011953078

#### 1. CHECK DTC PRIORITY

If DTC “C1A03” is displayed with DTC “U1000”, first diagnose the DTC “U1000”.

#### Is applicable DTC detected?

- YES >> Perform diagnosis of applicable.
- U1000: Refer to [DAS-65, "DTC Description"](#).
- NO >> GO TO 2.

A  
B  
C  
D  
E  
F  
G  
H  
I  
J  
K  
L  
M  
N  
P

## C1A03 VEHICLE SPEED SENSOR

< DTC/CIRCUIT DIAGNOSIS >

[ADAS CONTROL UNIT]

---

### 2. CHECK DATA MONITOR

---

1. Start the engine.
2. Drive the vehicle at 19 mph (30 km/h) or more.
3. Check that the value of "VHCL SPD SE" in "Data Monitor" mode of "ICC/ADAS" is almost the same as the actual vehicle speed.

**CAUTION:**

**Be careful of the vehicle speed.**

Is the inspection result normal?

- YES >> Replace the ADAS control unit. Refer to [DAS-80, "Removal and Installation"](#).  
NO >> GO TO 3.

### 3. CHECK ABS ACTUATOR AND ELECTRIC UNIT (CONTROL UNIT) SELF DIAGNOSTIC RESULT

---

Check if any DTC is detected in "Self Diagnostic Result" mode of "ABS".

Is any DTC detected?

- YES >> Perform diagnosis on the detected DTC and repair or replace the malfunctioning parts. Refer to [BRC-227, "DTC Index"](#).  
NO >> Replace the ADAS control unit. Refer to [DAS-80, "Removal and Installation"](#).

# C1A13 STOP LAMP RELAY

< DTC/CIRCUIT DIAGNOSIS >

[ADAS CONTROL UNIT]

## C1A13 STOP LAMP RELAY

### DTC Description

INFOID:0000000011953079

### DTC DETECTION LOGIC

DTC No.	CONSULT screen terms (Trouble diagnosis content)	DTC detection condition	
C1A13	STOP LAMP RLY FIX (Stop lamp relay fix)	Diagnosis condition	When ignition switch is ON.
		Signal (terminal)	–
		Threshold	<ul style="list-style-type: none"><li>• Stop lamp inactive state continues for 0.3 seconds or more despite the outputting of an ICC sensor ICC brake hold relay drive signal.</li><li>• The stop lamp remains ON for 60 seconds or more under the following conditions:<ul style="list-style-type: none"><li>- Driving at 25 mph (40 km/h) or more</li><li>- No stop lamp drive signal output from ADAS control unit</li><li>- No brake operation</li></ul></li></ul>
		Diagnosis delay time	–

### POSSIBLE CAUSE

- Stop lamp switch circuit
- ICC brake hold relay circuit
- Stop lamp switch
- ICC brake hold relay
- Incorrect stop lamp switch installation
- ECM
- ABS actuator and electric unit (control unit)

### FAIL-SAFE

The following systems are canceled:

- Intelligent Cruise Control (ICC)
- Forward Emergency Braking (FEB)
- Predictive Forward Collision Warning (PFCW)

### DTC CONFIRMATION PROCEDURE

#### 1. CHECK DTC PRIORITY

If DTC “C1A13” is displayed with DTC “U1000”, first diagnose the DTC “U1000”.

#### Is applicable DTC detected?

- YES >> Perform diagnosis of applicable. Refer to [DAS-65. "DTC Description"](#).  
NO >> GO TO 2.

#### 2. PERFORM DTC CONFIRMATION PROCEDURE (1)

##### CONSULT

1. Start the engine.
2. Select “STOP LAMP” “Active Test” mode of “ICC/ADAS”.
3. Select “All DTC Reading” mode.
4. Check if “C1A13” is detected as the current malfunction in the “Self Diagnostic Result” mode of “ICC/ADAS”.

#### Is “C1A13” detected as the current malfunction?

- YES >> Refer to [DAS-44. "Diagnosis Procedure"](#).  
NO >> GO TO 3.

#### 3. PERFORM DTC CONFIRMATION PROCEDURE (2)

##### CONSULT

A  
B  
C  
D  
E  
F  
G  
H  
I  
J  
K  
L  
M  
N  
P

DAS

# C1A13 STOP LAMP RELAY

[ADAS CONTROL UNIT]

< DTC/CIRCUIT DIAGNOSIS >

1. Drive the vehicle at 25 mph (40 km/h) or more for approximately 60 seconds or more without the brake pedal depressed.

**CAUTION:**

**Always drive safely.**

**NOTE:**

If it is outside the above condition, repeat step 1.

2. Select "All DTC Reading" mode.
3. Check if "C1A13" is detected as the current malfunction in the "Self Diagnostic Result" mode of "ICC/ADAS".

Is "C1A13" detected as the current malfunction?

YES >> Refer to [DAS-44, "Diagnosis Procedure"](#).

NO-1 >> To check malfunction symptom before repair: Refer to [GI-41, "Intermittent Incident"](#).

NO-2 >> Confirmation after repair: Inspection End.

## Diagnosis Procedure

INFOID:000000011953080

Regarding Wiring Diagram information, refer to [DAS-27, "Wiring Diagram"](#).

### 1. CHECK DTC PRIORITY

If DTC "C1A13" is displayed with DTC "U1000", first diagnose the DTC "U1000".

Is applicable DTC detected?

YES >> Perform diagnosis of applicable. Refer to [DAS-65, "DTC Description"](#).

NO >> GO TO 2.

### 2. CHECK STOP LAMP SWITCH

#### CONSULT

1. Select "Data Monitor" mode of "ICC/ADAS".
2. Select "STOP LAMP SW".
3. Check that the function operates normally according to the following conditions:

Monitor item	Condition	Status
STOP LAMP SW	When brake pedal is applied	ON
	When brake pedal is released	OFF

Is the inspection result normal?

YES >> GO TO 6.

NO >> GO TO 3.

### 3. CHECK STOP LAMP SWITCH INSTALLATION

1. Turn ignition switch OFF.
2. Check stop lamp switch for correct installation. Refer to [BR-12, "Inspection"](#).

Is the inspection result normal?

YES >> GO TO 4.

NO >> Adjust stop lamp switch installation. Refer to [BR-12, "Adjustment"](#).

### 4. CHECK STOP LAMP SWITCH

Check stop lamp switch. Refer to [CCS-78, "Component Inspection \(Stop Lamp Switch\)"](#).

Is the inspection result normal?

YES >> GO TO 5.

NO >> Replace stop lamp switch. Refer to [BR-20, "Exploded View"](#).

### 5. CHECK STOP LAMP FOR ILLUMINATION

1. Remove ICC brake hold relay.
2. Check that the stop lamp is illuminated by depressing the brake pedal to turn the stop lamp ON.

Is the inspection result normal?

YES >> GO TO 6.



# C1A13 STOP LAMP RELAY

[ADAS CONTROL UNIT]

< DTC/CIRCUIT DIAGNOSIS >

NO >> GO TO 7.

## 6. CHECK ICC BRAKE HOLD RELAY

Check ICC brake hold relay. Refer to [DAS-48, "Component Inspection"](#).

Is the inspection result normal?

YES >> GO TO 8.

NO >> Replace ICC brake hold relay.

## 7. CHECK STOP LAMP RELAY

Check stop lamp relay. Refer to [DAS-48, "Component Inspection"](#).

Is the inspection result normal?

YES >> GO TO 7.

NO >> Replace stop lamp relay.

## 8. CHECK ICC BRAKE HOLD RELAY POWER SUPPLY CIRCUIT

1. Turn ignition switch ON.
2. Check voltage between ICC brake hold relay harness connector and ground.

Terminal		Voltage (Approx.)
(+)	(-)	
ICC brake hold relay		Ground
Connector	Terminal	
E75	1 3	
		Battery voltage

Is the inspection result normal?

YES >> GO TO 9.

NO >> Repair or replace ICC brake hold relay power supply circuit.

## 9. CHECK HARNESS BETWEEN ICC BRAKE HOLD RELAY AND ADAS CONTROL UNIT

1. Disconnect ADAS control unit connector.
2. Check continuity between ICC brake hold relay harness connector and ADAS control unit harness connector.

ICC brake hold relay		ADAS control unit		Continuity
Connector	Terminal	Connector	Terminal	
E75	2	B89	14	Yes

3. Check continuity between ICC brake hold relay harness connector and ground.

ICC brake hold relay		Ground	Continuity
Connector	Terminal		
E75	2		No

Is the inspection result normal?

YES >> GO TO 10.

NO >> Repair or replace the harness or connector.

## 10. CHECK HARNESS BETWEEN ICC BRAKE HOLD RELAY AND ECM

1. Disconnect ECM, stop lamp relay, rear combination lamp, and high-mounted stop lamp connectors and remove ICC brake hold relay.
2. Turn ignition switch ON.
3. Check voltage between ICC brake hold relay harness connector and ground.

A  
B  
C  
D  
E  
F  
G  
H  
I  
J  
K  
L  
M  
N  
P

DAS

# C1A13 STOP LAMP RELAY

< DTC/CIRCUIT DIAGNOSIS >

[ADAS CONTROL UNIT]

ICC brake hold relay		Ground	Continuity
Connector	Terminal		
E75	5		No

4. Turn ignition switch OFF.
5. Check continuity between ICC brake hold relay harness connector and ECM harness connector.

ICC brake hold relay		ECM		Continuity
Connector	Terminal	Connector	Terminal	
E75	5	E10	139	

6. Check continuity between ICC brake hold relay harness connector and ground.

ICC brake hold relay		Ground	Continuity
Connector	Terminal		
E75	5		No

Is the inspection result normal?

- YES >> GO TO 11.  
 NO >> Repair or replace the harness or connector.

## 11. CHECK ICC BRAKE HOLD RELAY CONTROL CIRCUIT

### CONSULT

1. Connect all connectors again if the connectors are disconnected.
2. Select "STOP LAMP" in "Active Test" mode of "ICC/ADAS".
3. Select "Active Test" and check the voltage between ADAS control unit harness connector and ground.

Terminal		Ground	Condition	Voltage (Approx.)
(+)	(-)			
ADAS control unit			Active Test item "STOP LAMP"	
Connector	Terminal		OFF	Battery voltage
B89	14		ON	0 V

Is the inspection result normal?

- YES >> GO TO 12.  
 NO >> Replace ADAS control unit. Refer to [DAS-80. "Removal and Installation"](#).

## 12. CHECK STOP LAMP RELAY POWER SUPPLY CIRCUIT

Check voltage between stop lamp relay harness connector and ground.

Terminal		Ground	Voltage (Approx.)
(+)	(-)		
Stop lamp relay			Ground
Connector	Terminal		Battery voltage
E34	1		
	3		

Is the inspection result normal?

- YES >> GO TO 13.  
 NO >> Repair or replace stop lamp relay power supply circuit.

## 13. CHECK HARNESS BETWEEN STOP LAMP RELAY AND ECM

1. Turn the ignition switch OFF.

# C1A13 STOP LAMP RELAY

[ADAS CONTROL UNIT]

## < DTC/CIRCUIT DIAGNOSIS >

2. Disconnect stop lamp relay, ECM, ICC brake hold relay, rear combination lamp, and high-mounted stop lamp connectors.
3. Check continuity between the stop lamp relay harness connector and the ECM harness connector.

Stop lamp relay		ECM		Continuity
Connector	Terminal	Connector	Terminal	
E34	5	E10	139	Yes

4. Check continuity between stop lamp relay harness connector and ground.

Stop lamp relay		Ground	Continuity
Connector	Terminal		
E34	2		No

### Is the inspection result normal?

YES >> GO TO 14.

NO >> Repair the harness or connector.

## 14.CHECK HARNESS BETWEEN STOP LAMP RELAY AND STOP LAMP SWITCH

1. Turn the ignition switch OFF.
2. Disconnect stop lamp switch connector.
3. Check continuity between the stop lamp relay harness connector and the stop lamp switch harness connector.

Stop lamp relay		Stop lamp switch		Continuity
Connector	Terminal	Connector	Terminal	
E34	2	E38	2	Yes

4. Check continuity between stop lamp relay harness connector and ground.

Stop lamp relay		Ground	Continuity
Connector	Terminal		
E34	2		No

### Is the inspection result normal?

YES >> GO TO 15.

NO >> Repair the harness or connector.

## 15.CHECK STOP LAMP SWITCH GROUND CIRCUIT

Check continuity between stop lamp switch harness connector and ground.

Stop lamp switch		Ground	Continuity
Connector	Terminal		
E38	1		No

### Is the inspection result normal?

YES >> GO TO 16.

NO >> Repair the harness or connector.

## 16.PERFORM SELF-DIAGNOSIS OF ECM

### CONSULT

1. Connect all connectors again if the connectors are disconnected.
2. Turn ignition switch ON.
3. Select "All DTC Reading" mode.
4. Check if any DTC is detected in "Self Diagnostic Result" mode of "ENGINE". Refer to [EC-107](#), "DTC Index".

Is any DTC detected?

A  
B  
C  
D  
E  
F  
G  
H  
I  
J  
K  
L  
M  
N  
P

DAS

# C1A13 STOP LAMP RELAY

[ADAS CONTROL UNIT]

< DTC/CIRCUIT DIAGNOSIS >

- YES >> Repair or replace the malfunctioning parts identified by the self-diagnosis result.
- NO >> GO TO 17.

## 17.PERFORM SELF-DIAGNOSIS OF ABS ACTUATOR AND ELECTRIC UNIT (CONTROL UNIT)

### CONSULT

1. Connect all connectors again if the connectors are disconnected.
2. Turn ignition switch ON.
3. Select "All DTC Reading" mode.
4. Check if any DTC is detected in "Self Diagnostic Result" mode of "ABS". Refer to [BRC-227. "DTC Index"](#).

Is any DTC detected?

- YES >> Repair or replace the malfunctioning parts identified by the self-diagnosis result.
- NO >> Replace ADAS control unit. Refer to [DAS-80. "Removal and Installation"](#).

## Component Inspection

INFOID:000000011953081

### 1.CHECK ICC BRAKE HOLD RELAY

Apply battery voltage to ICC brake hold relay terminals 1 and 2, and then check for continuity under the following conditions:

ICC brake hold relay		Condition	Continuity
Terminals			
3	5	When the battery voltage is applied	Yes
		When the battery voltage is not applied	No

Is the inspection result normal?

- YES >> Inspection End.
- NO >> Replace ICC brake hold relay.

### 2.CHECK STOP LAMP RELAY

Apply battery voltage to stop lamp relay terminals 1 and 2, and then check for continuity under the following conditions:

Stop lamp relay		Condition	Continuity
Terminals			
3	5	When the battery voltage is applied	Yes
		When the battery voltage is not applied	No

Is the inspection result normal?

- YES >> Inspection End.
- NO >> Replace stop lamp relay.

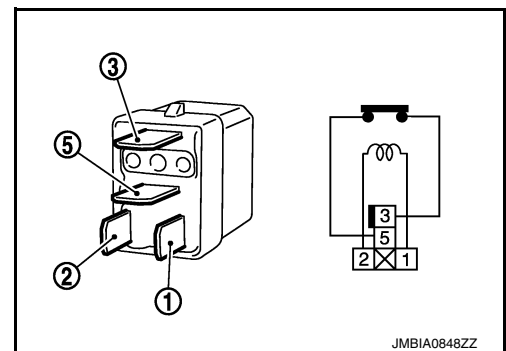
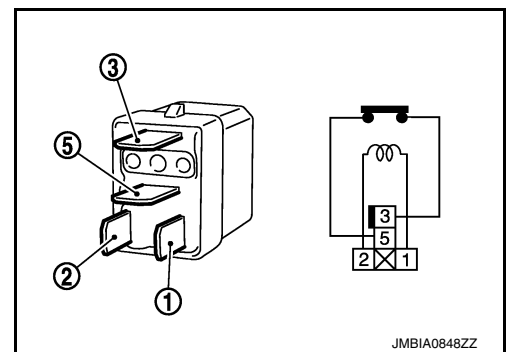

C1A14 ECM

DTC Description

INFOID:000000011953082

DTC DETECTION LOGIC

DTC No.	CONSULT screen terms (Trouble diagnosis content)	DTC detection condition	
		Diagnosis condition	When ignition switch is ON.
C1A14	ECM CIRCUIT (ECM circuit)	Signal (terminal)	-
		Threshold	If ECM is malfunctioning
		Diagnosis delay time	-

POSSIBLE CAUSE

- ECM
- ADAS control unit

FAIL-SAFE

The following systems are canceled:

- Intelligent Cruise Control (ICC)
- Forward Emergency Braking (FEB)
- Predictive Forward Collision Warning (PFCW)

DTC CONFIRMATION PROCEDURE

1.CHECK DTC PRIORITY

If DTC "C1A14" is displayed with DTC "U1000", first diagnose the DTC "U1000".

Is applicable DTC detected?

- YES >> Perform diagnosis of applicable. Refer to [DAS-65, "DTC Description"](#).
- NO >> GO TO 2.

2.PERFORM DTC CONFIRMATION PROCEDURE

CONSULT

1. Start the engine.
2. Operate the ICC system and drive.  
**CAUTION:**  
**Always drive safely.**
3. Stop the vehicle.
4. Select "All DTC Reading" mode.
5. Check if "C1A14" is detected as the current malfunction in "Self Diagnostic Result" mode of "ICC/ADAS".

Is "C1A14" detected as the current malfunction?

- YES >> Refer to [DAS-49, "Diagnosis Procedure"](#).
- NO-1 >> To check malfunction symptom before repair: Refer to [G1-41, "Intermittent Incident"](#).
- NO-2 >> Confirmation after repair: Inspection End.

Diagnosis Procedure

INFOID:000000011953083

1.CHECK DTC PRIORITY

If DTC "C1A14" is displayed with DTC "U1000", first diagnose the DTC "U1000".

Is applicable DTC detected?

- YES >> Perform diagnosis of applicable. Refer to [DAS-65, "DTC Description"](#).
- NO >> GO TO 2.

2.CHECK SELF-DIAGNOSIS RESULTS

Check if "U1000" is detected with "C1A14" in "Self Diagnostic Result" of "ICC/ADAS".

Is "U1000" detected?

A  
B  
C  
D  
E  
F  
G  
H  
I  
J  
K  
L  
M  
N



P

## C1A14 ECM

[ADAS CONTROL UNIT]

### < DTC/CIRCUIT DIAGNOSIS >

- YES >> Perform the CAN communication system inspection. Repair or replace the malfunctioning parts.  
Refer to [DAS-65, "DTC Description"](#).
- NO >> GO TO 3.

### 3.PERFORM SELF-DIAGNOSIS OF ECM

Check if any DTC is detected in "Self Diagnostic Result" mode of "ENGINE".

#### Is any DTC detected?

- YES >> Perform diagnosis on the detected DTC and repair or replace the malfunctioning parts. Refer to [EC-107, "DTC Index"](#).
- NO >> Replace the ADAS control unit. Refer to [DAS-80, "Removal and Installation"](#).

C1A17 ICC SENSOR

DTC Description

INFOID:000000011953084

DTC DETECTION LOGIC

DTC No.	CONSULT screen terms (Trouble diagnosis content)	DTC detection condition	
		Diagnosis condition	When ignition switch is ON.
C1A17	ICC SENSOR MALF (ICC sensor malfunction)	Signal (terminal)	-
		Threshold	If ICC sensor is malfunctioning
		Diagnosis delay time	-

**NOTE:**

If DTC "C1A17" is detected along with DTC "U1000", first diagnose the DTC "U1000". Refer to [DAS-65. "DTC Description"](#).

POSSIBLE CAUSE

ICC sensor

FAIL-SAFE

The following systems are canceled:

- Intelligent Cruise Control (ICC)
- Forward Emergency Braking (FEB)
- Predictive Forward Collision Warning (PFCW)

Diagnosis Procedure

INFOID:000000011953085

**1.** CHECK ADAS CONTROL UNIT SELF DIAGNOSTIC RESULT

ⓂCONSULT

1. Perform "All DTC Reading" mode.
2. Check if "U1000" is detected with "C1A17" in "Self Diagnostic Result" mode of "ICC/ADAS".

Is "U1000" detected?

- YES >> Perform diagnosis on the detected DTC and repair or replace the malfunctioning parts. Refer to [DAS-65. "DTC Description"](#).
- NO >> GO TO 2.

**2.** CHECK ICC SENSOR SELF DIAGNOSTIC RESULT

Check if any DTC is detected in "Self Diagnostic Result" mode of "LASER/RADAR".

Is any DTC detected?

- YES >> Perform diagnosis on the detected DTC and repair or replace the malfunctioning parts. Refer to [CCS-111. "DTC Logic"](#).
- NO >> Replace ADAS control unit. Refer to [DAS-80. "Removal and Installation"](#).

A  
B  
C  
D  
E  
F  
G  
H  
I  
J  
K  
L  
M  
N  
P



# C1A34 COMMAND ERROR

< DTC/CIRCUIT DIAGNOSIS >

[ADAS CONTROL UNIT]

## C1A34 COMMAND ERROR

### DTC Description

INFOID:000000011953086

### DTC DETECTION LOGIC

DTC No.	CONSULT screen terms (Trouble diagnosis content)	DTC detection condition	
C1A34	COMMAND ERROR (Command error)	Diagnosis condition	When ignition switch is ON.
		Signal (terminal)	–
		Threshold	If an error occurs in the command signal that ADAS control unit transmits to ECM via CAN communication
		Diagnosis delay time	–

### POSSIBLE CAUSE

ADAS control unit

### FAIL-SAFE

The following systems are canceled:

- Intelligent Cruise Control (ICC)
- Forward Emergency Braking (FEB)
- Predictive Forward Collision Warning (PFCW)

### DTC CONFIRMATION PROCEDURE

#### 1. CHECK DTC PRIORITY

If DTC “C1A34” is displayed with DTC “U1000”, first diagnose the DTC “U1000”.

#### Is applicable DTC detected?

- YES >> Perform diagnosis of applicable. Refer to [DAS-65, "DTC Description"](#).  
NO >> GO TO 2.

#### 2. PERFORM DTC CONFIRMATION PROCEDURE

##### CONSULT

1. Start the engine.
2. Operate the ICC system and drive.  
**CAUTION:**  
**Always drive safely.**
3. Stop the vehicle.
4. Select “All DTC Reading” mode.
5. Check if “C1A34” is detected as the current malfunction in “Self Diagnostic Result” mode of “ICC/ADAS”.

#### Is “C1A34” detected as the current malfunction?

- YES >> Refer to [DAS-52, "Diagnosis Procedure"](#).  
NO-1 >> To check malfunction symptom before repair: Refer to [GI-41, "Intermittent Incident"](#).  
NO-2 >> Confirmation after repair: Inspection End.

### Diagnosis Procedure

INFOID:000000011953087

#### 1. CHECK SELF-DIAGNOSIS RESULTS

Check if “U1000” is detected with “C1A34” in “Self Diagnostic Result” mode of “ICC/ADAS”.

#### Is “U1000” detected?

- YES >> Perform the CAN communication system inspection. Repair or replace the malfunctioning parts.  
Refer to [DAS-65, "DTC Description"](#).  
NO >> Replace the ADAS control unit. Refer to [DAS-80, "Removal and Installation"](#).



# C1B53 SIDE RADAR RIGHT MALFUNCTION

< DTC/CIRCUIT DIAGNOSIS >

[ADAS CONTROL UNIT]

## C1B53 SIDE RADAR RIGHT MALFUNCTION

### DTC Description

INFOID:000000011953088

### DTC DETECTION LOGIC

DTC No.	CONSULT screen terms (Trouble diagnosis content)	DTC detection condition	
C1B53	SIDE RDR R MALF (Side radar right malfunction)	Diagnosis condition	When ignition switch is ON.
		Signal (terminal)	–
		Threshold	ADAS control unit detects that side radar RH has a malfunction
		Diagnosis delay time	–

### POSSIBLE CAUSE

Side radar RH

### FAIL-SAFE

The following systems are canceled:

- Blind Spot Warning (BSW)
- Rear Cross Traffic Alert (RCTA)

### DTC CONFIRMATION PROCEDURE

#### 1. PERFORM DTC CONFIRMATION PROCEDURE

##### CONSULT

1. Start the engine.
2. Select "All DTC Reading" mode.
3. Check if "C1B53" is detected as the current malfunction in "Self Diagnostic Result" mode of "ICC/ADAS".

##### Is "C1B53" detected as the current malfunction?

- YES >> Refer to [DAS-53, "Diagnosis Procedure"](#).
- NO-1 >> To check malfunction symptom before repair: Refer to [GI-41, "Intermittent Incident"](#).
- NO-2 >> Confirmation after repair: Inspection End.

### Diagnosis Procedure

INFOID:000000011953089

#### 1. CHECK SELF DIAGNOSTIC RESULT

Check if "U1000" is detected with "C1B53" in "Self Diagnostic Result" mode of "ICC/ADAS".

##### Is "U1000" detected?

- YES >> Perform the CAN communication system inspection. Repair or replace the malfunctioning parts. Refer to [DAS-65, "DTC Description"](#).
- NO >> GO TO 2.

#### 2. CHECK SELF DIAGNOSTIC RESULT

Check if any DTC is detected in "Self Diagnostic Result" mode of "SIDE RADAR RIGHT".

##### Is any DTC detected?

- YES >> Perform diagnosis on the detected DTC and repair or replace the malfunctioning parts. Refer to [DAS-129, "DTC Index"](#) (Side radar RH).
- NO >> Replace the ADAS control unit. Refer to [DAS-80, "Removal and Installation"](#).

# C1B54 SIDE RADAR LEFT MALFUNCTION

< DTC/CIRCUIT DIAGNOSIS >

[ADAS CONTROL UNIT]

## C1B54 SIDE RADAR LEFT MALFUNCTION

### DTC Description

INFOID:000000011953090

### DTC DETECTION LOGIC

DTC No.	CONSULT screen terms (Trouble diagnosis content)	DTC detection condition	
C1B54	SIDE RDR L MALF (Side radar left malfunction)	Diagnosis condition	When ignition switch is ON.
		Signal (terminal)	–
		Threshold	ADAS control unit detects that side radar LH has a malfunction
		Diagnosis delay time	–

### POSSIBLE CAUSE

Side radar LH

### FAIL-SAFE

The following systems are canceled:

- Blind Spot Warning (BSW)
- Rear Cross Traffic Alert (RCTA)

### DTC CONFIRMATION PROCEDURE

#### 1.PERFORM DTC CONFIRMATION PROCEDURE

##### CONSULT

1. Start the engine.
2. Select "All DTC Reading" mode.
3. Check if "C1B54" is detected as the current malfunction in "Self Diagnostic Result" mode of "ICC/ADAS".

Is "C1B54" detected as the current malfunction?

- YES >> Refer to [DAS-54, "Diagnosis Procedure"](#).  
NO-1 >> To check malfunction symptom before repair: Refer to [GI-41, "Intermittent Incident"](#).  
NO-2 >> Confirmation after repair: Inspection End.

### Diagnosis Procedure

INFOID:000000011953091

#### 1.CHECK SELF DIAGNOSTIC RESULT

Check if "U1000" is detected with "C1B54" in "Self Diagnostic Result" mode of "ICC/ADAS".

Is "U1000" detected?

- YES >> Perform the CAN communication system inspection. Repair or replace the malfunctioning parts.  
Refer to [DAS-65, "DTC Description"](#).  
NO >> GO TO 2.

#### 2.CHECK SELF DIAGNOSTIC RESULT

Check if any DTC is detected in "Self Diagnostic Result" mode of "SIDE RADAR LEFT".

Is any DTC detected?

- YES >> Perform diagnosis on the detected DTC and repair or replace the malfunctioning parts. Refer to [DAS-127, "DTC Index"](#) (Side radar LH).  
NO >> Replace the ADAS control unit. Refer to [DAS-80, "Removal and Installation"](#).

U0121 VDC CAN 2

DTC Description

INFOID:0000000011953092

DTC DETECTION LOGIC

DTC No.	CONSULT screen terms (Trouble diagnosis content)	DTC detection condition	
U0121	VDC CAN CIR2 (VDC CAN circuit 2)	Diagnosis condition	When ignition switch is ON.
		Signal (terminal)	–
		Threshold	If ADAS control unit detects an error signal that is received from ABS actuator and electric unit (control unit) via CAN communication
		Diagnosis delay time	–

POSSIBLE CAUSE

ABS actuator and electric unit (control unit)

FAIL-SAFE

The following systems are canceled:

- Intelligent Cruise Control (ICC)
- Forward Emergency Braking (FEB)
- Predictive Forward Collision Warning (PFCW)
- Blind Spot Warning (BSW)
- Rear Cross Traffic Alert (RCTA)

DTC CONFIRMATION PROCEDURE

1.CHECK DTC PRIORITY

If DTC “U0121” is displayed with DTC “U1000”, first diagnose the DTC “U1000”.

Is applicable DTC detected?

- YES >> Perform diagnosis of applicable. Refer to [DAS-65, "DTC Description"](#).
- NO >> GO TO 2.

2.PERFORM DTC CONFIRMATION PROCEDURE

ⓂCONSULT

1. Start the engine.
2. Turn the MAIN switch of ICC system ON.
3. Select “All DTC Reading” mode.
4. Check if “U0121” is detected as the current malfunction in “Self Diagnostic Result” mode of “ICC/ADAS”.

Is “U0121” detected as the current malfunction?

- YES >> Refer to [DAS-55, "Diagnosis Procedure"](#).
- NO-1 >> To check malfunction symptom before repair: Refer to [GI-41, "Intermittent Incident"](#).
- NO-2 >> Confirmation after repair: Inspection End.

Diagnosis Procedure

INFOID:0000000011953093

1.CHECK DTC PRIORITY

If DTC “U0121” is displayed with DTC “U1000”, first diagnose the DTC “U1000”.

Is applicable DTC detected?

- YES >> Perform diagnosis of applicable. Refer to [DAS-65, "DTC Description"](#).
- NO >> GO TO 2.

2.CHECK ABS ACTUATOR AND ELECTRIC UNIT (CONTROL UNIT) SELF-DIAGNOSIS RESULTS

Check if any DTC is detected in “Self Diagnostic Result” mode of “ABS”.

Is any DTC detected?



A  
B  
C  
D  
E  
F  
G  
H  
I  
J  
K  
L  
M  
N  
P

## U0121 VDC CAN 2

< DTC/CIRCUIT DIAGNOSIS >

[ADAS CONTROL UNIT]

- 
- YES >> Perform diagnosis on the detected DTC and repair or replace the malfunctioning parts. Refer to [BRC-227, "DTC Index"](#).
- NO >> Replace the ADAS control unit. Refer to [DAS-80, "Removal and Installation"](#).

# U0235 ICC SENSOR CAN 1

< DTC/CIRCUIT DIAGNOSIS >

[ADAS CONTROL UNIT]

## U0235 ICC SENSOR CAN 1

### DTC Description

INFOID:000000011953094

### DTC DETECTION LOGIC

DTC No.	CONSULT screen terms (Trouble diagnosis content)	DTC detection condition	
U0235	ICC SENSOR CAN CIR1 (ICC sensor CAN circuit 1)	Diagnosis condition	When ignition switch is ON.
		Signal (terminal)	–
		Threshold	ADAS control unit detects an error signal that is received from ICC sensor via ITS communication
		Diagnosis delay time	–

### POSSIBLE CAUSE

ICC sensor

### FAIL-SAFE

The following systems are canceled:

- Intelligent Cruise Control (ICC)
- Forward Emergency Braking (FEB)
- Predictive Forward Collision Warning (PFCW)

### DTC CONFIRMATION PROCEDURE

#### 1. CHECK DTC PRIORITY

If DTC “U0235” is displayed with DTC “U1000”, first diagnose the DTC “U1000”.

#### Is applicable DTC detected?

- YES >> Perform diagnosis of applicable. Refer to [DAS-65, "DTC Description"](#).  
NO >> GO TO 2.

#### 2. PERFORM DTC CONFIRMATION PROCEDURE

##### CONSULT

1. Start the engine.
2. Turn the MAIN switch of ICC system ON.
3. Select “All DTC Reading” mode.
4. Check if “U0235” is detected as the current malfunction in “Self Diagnostic Result” mode of “ICC/ADAS”.

#### Is “U0235” detected as the current malfunction?

- YES >> Refer to [DAS-57, "Diagnosis Procedure"](#).  
NO-1 >> To check malfunction symptom before repair: Refer to [GI-41, "Intermittent Incident"](#).  
NO-2 >> Confirmation after repair: Inspection End.

### Diagnosis Procedure

INFOID:000000011953095

#### 1. CHECK DTC PRIORITY

If DTC “U0235” is displayed with DTC “U1000”, first diagnose the DTC “U1000”.

#### Is applicable DTC detected?

- YES >> Perform diagnosis of applicable. Refer to [DAS-65, "DTC Description"](#).  
NO >> GO TO 2.

#### 2. CHECK ICC SENSOR SELF DIAGNOSTIC RESULT

Check if any DTC is detected in “Self Diagnostic Result” mode of “LASER/RADAR”.

#### Is any DTC detected?

- YES >> Perform diagnosis on the detected DTC and repair or replace the malfunctioning parts. Refer to [CCS-46, "DTC Index"](#).  
NO >> Replace the ADAS control unit. Refer to [DAS-80, "Removal and Installation"](#).

A  
B  
C  
D  
E  
F  
G  
H  
I  
J  
K  
L  
M  
N  
P

DAS

U0401 ECM CAN 1

DTC Description

INFOID:000000011953096

DTC DETECTION LOGIC

DTC No.	CONSULT screen terms (Trouble diagnosis content)	DTC detection condition	
U0401	ECM CAN CIR1 (ECM CAN circuit 1)	Diagnosis condition	When ignition switch is ON.
		Signal (terminal)	–
		Threshold	If ADAS control unit detects an error signal that is received from ECM via CAN communication
		Diagnosis delay time	–

POSSIBLE CAUSE

ECM

FAIL-SAFE

The following systems are canceled:

- Intelligent Cruise Control (ICC)
- Forward Emergency Braking (FEB)
- Predictive Forward Collision Warning (PFCW)
- Blind Spot Warning (BSW)
- Rear Cross Traffic Alert (RCTA)

DTC CONFIRMATION PROCEDURE

1. CHECK DTC PRIORITY

If DTC “U0401” is displayed with DTC “U1000”, first diagnose the DTC “U1000”.

Is applicable DTC detected?

- YES >> Perform diagnosis of applicable. Refer to [DAS-65, "DTC Description"](#).
- NO >> GO TO 2.

2. PERFORM DTC CONFIRMATION PROCEDURE

CONSULT

1. Start the engine.
2. Turn the MAIN switch of ICC system ON.
3. Select “All DTC Reading” mode.
4. Check if “U0401” is detected as the current malfunction in “Self Diagnostic Result” mode of “ICC/ADAS”.

Is “U0401” detected as the current malfunction?

- YES >> Refer to [DAS-58, "Diagnosis Procedure"](#).
- NO-1 >> To check malfunction symptom before repair: Refer to [GI-41, "Intermittent Incident"](#).
- NO-2 >> Confirmation after repair: Inspection End.

Diagnosis Procedure

INFOID:000000011953097

1. CHECK DTC PRIORITY

If DTC “U0401” is displayed with DTC “U1000”, first diagnose the DTC “U1000”.

Is applicable DTC detected?

- YES >> Perform diagnosis of applicable. Refer to [DAS-65, "DTC Description"](#).
- NO >> GO TO 2.

2. CHECK ECM SELF DIAGNOSTIC RESULT

Check if any DTC is detected in “Self Diagnostic Result” mode of “ENGINE”.

Is any DTC detected?

## U0401 ECM CAN 1

< DTC/CIRCUIT DIAGNOSIS >

[ADAS CONTROL UNIT]

- YES >> Perform diagnosis on the detected DTC and repair or replace the malfunctioning parts. Refer to [BRC-227, "DTC Index"](#).
- NO >> Replace the ADAS control unit. Refer to [DAS-80, "Removal and Installation"](#).

A  
B  
C  
D  
E  
F  
G  
H  
I  
J  
K  
L  
M  
N  
P

DAS

U0402 TCM CAN 1

DTC Description

INFOID:000000011953098

DTC DETECTION LOGIC

DTC No.	CONSULT screen terms (Trouble diagnosis content)	DTC detection condition	
U0402	TCM CAN CIRC1 (TCM CAN circuit 1)	Diagnosis condition	When ignition switch is ON.
		Signal (terminal)	–
		Threshold	If ADAS control unit detects an error signal that is received from TCM via CAN communication
		Diagnosis delay time	–

POSSIBLE CAUSE

TCM

FAIL-SAFE

The following systems are canceled:

- Intelligent Cruise Control (ICC)
- Forward Emergency Braking (FEB)
- Predictive Forward Collision Warning (PFCW)
- Blind Spot Warning (BSW)
- Rear Cross Traffic Alert (RCTA)

DTC CONFIRMATION PROCEDURE

1. CHECK DTC PRIORITY

If DTC “U0402” is displayed with DTC “U1000”, first diagnose the DTC “U1000”.

Is applicable DTC detected?

- YES >> Perform diagnosis of applicable. Refer to [DAS-65, "DTC Description"](#).
- NO >> GO TO 2.

2. PERFORM DTC CONFIRMATION PROCEDURE

CONSULT

1. Start the engine.
2. Turn the MAIN switch of ICC system ON.
3. Select “All DTC Reading” mode.
4. Check if “U0402” is detected as the current malfunction in “Self Diagnostic Result” mode of “ICC/ADAS”.

Is “U0402” detected as the current malfunction?

- YES >> Refer to [DAS-60, "Diagnosis Procedure"](#).
- NO-1 >> To check malfunction symptom before repair: Refer to [GI-41, "Intermittent Incident"](#).
- NO-2 >> Confirmation after repair: Inspection End.

Diagnosis Procedure

INFOID:000000011953099

1. CHECK DTC PRIORITY

If DTC “U0402” is displayed with DTC “U1000”, first diagnose the DTC “U1000”.

Is applicable DTC detected?

- YES >> Perform diagnosis of applicable. Refer to [DAS-65, "DTC Description"](#).
- NO >> GO TO 2.

2. CHECK TCM SELF DIAGNOSTIC RESULT

Check if any DTC is detected in “Self Diagnostic Result” mode of “TRANSMISSION”.

Is any DTC detected?



## U0402 TCM CAN 1

< DTC/CIRCUIT DIAGNOSIS >

[ADAS CONTROL UNIT]

- YES >> Perform diagnosis on the detected DTC and repair or replace the malfunctioning parts. Refer to [TM-58, "DTC Index"](#).
- NO >> Replace the ADAS control unit. Refer to [DAS-80, "Removal and Installation"](#).

A  
B  
C  
D  
E  
F  
G  
H  
I  
J  
K  
L  
M  
N  
P

DAS

U0415 VDC CAN 1

DTC Description

INFOID:000000011953100

DTC DETECTION LOGIC

DTC No.	CONSULT screen terms (Trouble diagnosis content)	DTC detection condition	
U0415	VDC CAN CIR1 (VDC CAN circuit 1)	Diagnosis condition	When ignition switch is ON.
		Signal (terminal)	–
		Threshold	If ADAS control unit detects an error signal that is received from ABS actuator and electric unit (control unit) via CAN communication
		Diagnosis delay time	–

POSSIBLE CAUSE

ABS actuator and electric unit (control unit)

FAIL-SAFE

The following systems are canceled:

- Intelligent Cruise Control (ICC)
- Forward Emergency Braking (FEB)
- Predictive Forward Collision Warning (PFCW)
- Blind Spot Warning (BSW)
- Rear Cross Traffic Alert (RCTA)

DTC CONFIRMATION PROCEDURE

1.CHECK DTC PRIORITY

If DTC “U0415” is displayed with DTC “U1000”, first diagnose the DTC “U1000”.

Is applicable DTC detected?

- YES >> Perform diagnosis of applicable. Refer to [DAS-65, "DTC Description"](#).
- NO >> GO TO 2.

2.PERFORM DTC CONFIRMATION PROCEDURE

ⓂCONSULT

1. Start the engine.
2. Turn the MAIN switch of ICC system ON.
3. Select “All DTC Reading” mode.
4. Check if “U0415” is detected as the current malfunction in “Self Diagnostic Result” mode of “ICC/ADAS”.

Is “U0415” detected as the current malfunction?

- YES >> Refer to [DAS-62, "Diagnosis Procedure"](#).
- NO-1 >> To check malfunction symptom before repair: Refer to [GI-41, "Intermittent Incident"](#).
- NO-2 >> Confirmation after repair: Inspection End.

Diagnosis Procedure

INFOID:000000011953101

1.CHECK DTC PRIORITY

If DTC “U0415” is displayed with DTC “U1000”, first diagnose the DTC “U1000”.

Is applicable DTC detected?

- YES >> Perform diagnosis of applicable. Refer to [DAS-65, "DTC Description"](#).
- NO >> GO TO 2.

2.CHECK ABS ACTUATOR AND ELECTRIC UNIT (CONTROL UNIT) SELF DIAGNOSTIC RESULT

Check if any DTC is detected in “Self Diagnostic Result” mode of “ABS”.

Is any DTC detected?

# U0415 VDC CAN 1

< DTC/CIRCUIT DIAGNOSIS >

[ADAS CONTROL UNIT]

- YES >> Perform diagnosis on the detected DTC and repair or replace the malfunctioning parts. Refer to [BRC-227, "DTC Index"](#).
- NO >> Replace the ADAS control unit. Refer to [DAS-80, "Removal and Installation"](#).

A  
B  
C  
D  
E  
F  
G  
H  
I  
J  
K  
L  
M  
N  
P

DAS

**U0433 DIST SEN CAN CIRC 2**

**DTC Description**

INFOID:000000011953102

**DTC DETECTION LOGIC**

DTC No.	CONSULT screen terms (Trouble diagnosis content)	DTC detection condition	
U0433	ICC SENSOR CAN CIRC 2 (ICC sensor CAN circuit 2)	Diagnosis condition	When ignition switch is ON.
		Signal (terminal)	–
		Threshold	ADAS control unit received invalid data from ICC sensor via ITS communication
		Diagnosis delay time	–

**POSSIBLE CAUSE**

ICC sensor  
ADAS control unit

**FAIL-SAFE**

The following systems are canceled:

- Intelligent Cruise Control (ICC)
- Forward Emergency Braking (FEB)
- Predictive Forward Collision Warning (PFCW)

**DTC CONFIRMATION PROCEDURE**

**1. CHECK DTC PRIORITY**

If DTC “U0433” is displayed with DTC “U1000”, first diagnose the DTC “U1000”.

Is applicable DTC detected?

- YES >> Perform diagnosis of applicable. Refer to [DAS-65, "DTC Description"](#).  
NO >> GO TO 2.

**2. PERFORM DTC CONFIRMATION PROCEDURE**

**CONSULT**

1. Start the engine.
2. Turn the MAIN switch of ICC system ON.
3. Select “All DTC Reading” mode.
4. Check if “U0433” is detected as the current malfunction in “Self Diagnostic Result” mode of “ICC/ADAS”.

Is “U0433” detected as the current malfunction?

- YES >> Refer to [DAS-64, "Diagnosis Procedure"](#).  
NO-1 >> To check malfunction symptom before repair: Refer to [GI-41, "Intermittent Incident"](#).  
NO-2 >> Confirmation after repair: Inspection End.

**Diagnosis Procedure**

INFOID:000000011953103

**1. CHECK DTC PRIORITY**

If DTC “U0433” is displayed with DTC “U1000”, first diagnose the DTC “U1000”.

Is applicable DTC detected?

- YES >> Perform diagnosis of applicable. Refer to [DAS-65, "DTC Description"](#).  
NO >> GO TO 2.

**2. CHECK ICC SENSOR SELF DIAGNOSTIC RESULT**

Check if any DTC is detected in “Self Diagnostic Result” mode of “LASER/RADAR”.

Is any DTC detected?

- YES >> Perform diagnosis on the detected DTC and repair or replace the malfunctioning parts. Refer to [CCS-46, "DTC Index"](#).  
NO >> Replace the ADAS control unit. Refer to [DAS-80, "Removal and Installation"](#).

## U1000 CAN COMM CIRCUIT

### Description

INFOID:0000000011953104

#### CAN COMMUNICATION

CAN (Controller Area Network) is a serial communication line for real time applications. It is an on-vehicle multiplex communication line with high data communication speed and excellent error detection ability. Modern vehicles are equipped with many electronic control units, and each control unit shares information and links with other control units during operation (not independent). In CAN communication, control units are connected with 2 communication lines (CAN-H, CAN-L) allowing a high rate of information transmission with less wiring. Each control unit transmits/receives data but selectively reads the required data only.

CAN communication signal chart. Refer to [LAN-32, "CAN COMMUNICATION SYSTEM : CAN Communication Signal Chart"](#).

#### ITS COMMUNICATION

- ITS communication is a multiplex communication system. This enables the system to transmit and receive large quantities of data at high speed by connecting control units with 2 communication lines.
- ITS communication lines adopt twisted-pair line style (two lines twisted) for noise immunity.

### DTC Description

INFOID:0000000011953105

#### DTC DETECTION LOGIC

DTC No.	CONSULT screen terms (Trouble diagnosis content)	DTC detection condition	
		Diagnosis condition	When ignition switch is ON.
U1000	CAN COMM CIRCUIT (CAN communication circuit)	Signal (terminal)	–
		Threshold	If ADAS control unit is not transmitting or receiving CAN communication signal or ITS communication
		Diagnosis delay time	2 seconds or more

#### NOTE:

If “U1000” is detected, first diagnose the CAN communication system.

#### POSSIBLE CAUSE

- CAN communication system
- ITS communication system

#### FAIL-SAFE

The following systems are canceled:

- Intelligent Cruise Control (ICC)
- Forward Emergency Braking (FEB)
- Predictive Forward Collision Warning (PFCW)
- Blind Spot Warning (BSW)
- Rear Cross Traffic Alert (RCTA)

#### NOTE:

With the detection of “U1000”, some systems do not perform the fail-safe operation. A system controlling based on a signal received from the control unit performs fail-safe operation when the communication with the ADAS control unit becomes inoperable.

#### DTC CONFIRMATION PROCEDURE

##### 1. PERFORM DTC CONFIRMATION PROCEDURE

#### CONSULT

1. Start the engine.
2. Turn the MAIN switch of ICC system ON.
3. Select “All DTC Reading” mode.
4. Check if the “U1000” is detected as the current malfunction in “Self Diagnostic Result” mode of “ICC/ADAS”.

Is “U1000” detected as the current malfunction?

A  
B  
C  
D  
E  
F  
G  
H  
I  
J  
K  
L  
M  
N  
P



# U1000 CAN COMM CIRCUIT

[ADAS CONTROL UNIT]

< DTC/CIRCUIT DIAGNOSIS >

- YES >> Refer to [DAS-66, "Diagnosis Procedure"](#).  
NO-1 >> To check malfunction symptom before repair: Refer to [GI-41, "Intermittent Incident"](#).  
NO-2 >> Confirmation after repair: Inspection End.

## Diagnosis Procedure

INFOID:0000000011953106

### 1. PERFORM THE SELF DIAGNOSTIC RESULT

#### Ⓟ CONSULT

1. Turn the ignition switch ON.
2. Turn the MAIN switch of ICC system ON, and then wait for 30 seconds or more.
3. Select "All DTC Reading" mode.
4. Check if "U1000" is detected as the current malfunction in "Self Diagnostic Result" of "ICC/ADAS".

#### Is "U1000" detected as the current malfunction?

- YES >> Refer to [LAN-17, "Trouble Diagnosis Flow Chart"](#).  
NO >> Inspection End.

# U1321 CONFIGURATION

< DTC/CIRCUIT DIAGNOSIS >

[ADAS CONTROL UNIT]

## U1321 CONFIGURATION

### DTC Description

INFOID:0000000011953107

### DTC DETECTION LOGIC

DTC No.	CONSULT screen terms (Trouble diagnosis content)	DTC detecting condition	
U1321	NOT CONFIGURED	Diagnosis condition	When ignition switch is ON.
		Signal (terminal)	—
		Threshold	If ADAS is not configured
		Diagnosis delay time	—

### POSSIBLE CAUSE

ADAS control unit is not configured.

### FAIL-SAFE

The following systems are canceled:

- Intelligent Cruise Control (ICC)
- Forward Emergency Braking (FEB)
- Predictive Forward Collision Warning (PFCW)
- Blind Spot Warning (BSW)
- Rear Cross Traffic Alert (RCTA)

### DTC CONFIRMATION PROCEDURE

#### 1.PERFORM DTC CONFIRMATION PROCEDURE

##### CONSULT

1. Start the engine.
2. Select "All DTC Reading" mode.
3. Check if "U1321" is detected as the current malfunction in "Self Diagnostic Result" mode of "ICC/ADAS".

##### Is "U1321" detected as the current malfunction?

- YES >> Refer to [DAS-67. "Diagnosis Procedure"](#).  
NO >> Inspection End.

### Diagnosis Procedure

INFOID:0000000011953108

#### 1.PERFORM CONFIGURATION OF ADAS CONTROL UNIT

Perform configuration of ADAS control unit when DTC "U1321" is detected.

>> Perform configuration of ADAS control unit. Refer to [DAS-37. "Work Procedure"](#).

A  
B  
C  
D  
E  
F  
G  
H  
I  
J  
K  
L  
M  
N  
P

DAS

U1503 SIDE RDR L CAN 2

DTC Description

INFOID:000000011953109

DTC DETECTION LOGIC

DTC No.	CONSULT screen terms (Trouble diagnosis content)	DTC detection condition	
U1503	SIDE RDR L CAN CIR 2 (Side radar left CAN circuit 2)	Diagnosis condition	When ignition switch is ON.
		Signal (terminal)	-
		Threshold	ADAS control unit detects an error signal that is received from side radar LH via ITS communication
		Diagnosis delay time	-

POSSIBLE CAUSE

Side radar LH

FAIL-SAFE

The following systems are canceled:

- Blind Spot Warning (BSW)
- Rear Cross Traffic Alert (RCTA)

DTC CONFIRMATION PROCEDURE

1.CHECK DTC PRIORITY

If DTC "U1503" is displayed with DTC "U1000" or "U1508", first diagnose the DTC "U1000" or "U1508".

Is applicable DTC detected?

- YES >> Perform diagnosis of applicable.
- U1000: Refer to [DAS-65, "DTC Description"](#).
  - U1508: Refer to [DAS-77, "DTC Description"](#).

NO >> GO TO 2.

2.PERFORM DTC CONFIRMATION PROCEDURE

 CONSULT

1. Start the engine.
2. Turn the Blind Spot Warning system ON.
3. Select "All DTC Reading" mode.
4. Check if "U1503" is detected as the current malfunction in "Self Diagnostic Result" mode of "ICC/ADAS".

Is "U1503" detected as the current malfunction?

- YES >> Refer to [DAS-68, "Diagnosis Procedure"](#).
- NO-1 >> To check malfunction symptom before repair: Refer to [GI-41, "Intermittent Incident"](#).
- NO-2 >> Confirmation after repair: Inspection End.

Diagnosis Procedure

INFOID:000000011953110

1.CHECK DTC PRIORITY

If DTC "U1503" is displayed with DTC "U1000" or "U1508", first diagnose the DTC "U1000" or "U1508".

Is applicable DTC detected?

- YES >> Perform diagnosis of applicable.
- U1000: Refer to [DAS-65, "DTC Description"](#).
  - U1508: Refer to [DAS-77, "DTC Description"](#).

NO >> GO TO 2.

2.CHECK SIDE RADAR LH SELF DIAGNOSTIC RESULT

Check if any DTC is detected in "Self Diagnostic Result" mode of "SIDE RADAR LEFT".

Is any DTC detected?



## U1503 SIDE RDR L CAN 2

< DTC/CIRCUIT DIAGNOSIS >

[ADAS CONTROL UNIT]

- YES >> Perform diagnosis on the detected DTC and repair or replace the malfunctioning parts. Refer to [DAS-127, "DTC Index"](#).
- NO >> Replace the ADAS control unit. Refer to [DAS-80, "Removal and Installation"](#).

A  
B  
C  
D  
E  
F  
G  
H  
I  
J  
K  
L  
M  
N  
P

DAS

U1504 SIDE RDR L CAN 1

DTC Description

INFOID:0000000011953111

DTC DETECTION LOGIC

DTC No.	CONSULT screen terms (Trouble diagnosis content)	DTC detection condition	
U1504	SIDE RDR L CAN CIR 1 (Side radar left CAN circuit 1)	Diagnosis condition	When ignition switch is ON.
		Signal (terminal)	–
		Threshold	ADAS control unit detects an error signal that is received from side radar LH via ITS communication
		Diagnosis delay time	–

POSSIBLE CAUSE

Side radar LH

FAIL-SAFE

The following systems are canceled:

- Blind Spot Warning (BSW)
- Rear Cross Traffic Alert (RCTA)

DTC CONFIRMATION PROCEDURE

1.CHECK DTC PRIORITY

If DTC “U1504” is displayed with DTC “U1000” or “U1508”, first diagnose the DTC “U1000” or “U1508”.

Is applicable DTC detected?

- YES >> Perform diagnosis of applicable.
- U1000: Refer to [DAS-65, "DTC Description"](#).
  - U1508: Refer to [DAS-77, "DTC Description"](#).
- NO >> GO TO 2.

2.PERFORM DTC CONFIRMATION PROCEDURE

CONSULT

1. Start the engine.
2. Turn the Blind Spot Warning system ON.
3. Select “All DTC Reading” mode.
4. Check if “U1504” is detected as the current malfunction in “Self Diagnostic Result” mode of “ICC/ADAS”.

Is “U1504” detected as the current malfunction?

- YES >> Refer to [DAS-70, "Diagnosis Procedure"](#).
- NO-1 >> To check malfunction symptom before repair: Refer to [GI-41, "Intermittent Incident"](#).
- NO-2 >> Confirmation after repair: Inspection End.

Diagnosis Procedure

INFOID:0000000011953112

1.CHECK DTC PRIORITY

If DTC “U1504” is displayed with DTC “U1000” or “U1508”, first diagnose the DTC “U1000” or “U1508”.

Is applicable DTC detected?

- YES >> Perform diagnosis of applicable.
- U1000: Refer to [DAS-65, "DTC Description"](#).
  - U1508: Refer to [DAS-77, "DTC Description"](#).
- NO >> GO TO 2.

2.CHECK SIDE RADAR LH SELF DIAGNOSTIC RESULT

Check if any DTC is detected in “Self Diagnostic Result” mode of “SIDE RADAR LEFT”.

Is any DTC detected?

# U1504 SIDE RDR L CAN 1

< DTC/CIRCUIT DIAGNOSIS >

[ADAS CONTROL UNIT]

- YES >> Perform diagnosis on the detected DTC and repair or replace the malfunctioning parts. Refer to [DAS-127, "DTC Index"](#).
- NO >> Replace the ADAS control unit. Refer to [DAS-80, "Removal and Installation"](#).

A  
B  
C  
D  
E  
F  
G  
H  
I  
J  
K  
L  
M  
N  
P

DAS

## U1505 SIDE RDR R CAN 2

### DTC Description

INFOID:000000011953113

### DTC DETECTION LOGIC

DTC No.	CONSULT screen terms (Trouble diagnosis content)	DTC detection condition	
U1505	SIDE RDR R CAN CIR 2 (Side radar right CAN circuit 2)	Diagnosis condition	When ignition switch is ON.
		Signal (terminal)	-
		Threshold	ADAS control unit detects an error signal that is received from side radar RH via ITS communication
		Diagnosis delay time	-

### POSSIBLE CAUSE

Side radar RH

### FAIL-SAFE

The following systems are canceled:

- Blind Spot Warning (BSW)
- Rear Cross Traffic Alert (RCTA)

### DTC CONFIRMATION PROCEDURE

#### 1. CHECK DTC PRIORITY

If DTC "U1505" is displayed with DTC "U1000" or "U1507", first diagnose the DTC "U1000" or "U1507".

#### Is applicable DTC detected?

- YES >> Perform diagnosis of applicable.
- U1000: Refer to [DAS-65, "DTC Description"](#).
  - U1507: Refer to [DAS-76, "DTC Description"](#).
- NO >> GO TO 2.

#### 2. PERFORM DTC CONFIRMATION PROCEDURE

#### CONSULT

1. Start the engine.
2. Turn the Blind Spot Warning system ON.
3. Select "All DTC Reading" mode.
4. Check if "U1505" is detected as the current malfunction in "Self Diagnostic Result" mode of "ICC/ADAS".

#### Is "U1505" detected as the current malfunction?

- YES >> Refer to [DAS-72, "Diagnosis Procedure"](#).
- NO-1 >> To check malfunction symptom before repair: Refer to [GI-41, "Intermittent Incident"](#).
- NO-2 >> Confirmation after repair: Inspection End.

### Diagnosis Procedure

INFOID:000000011953114

#### 1. CHECK DTC PRIORITY

If DTC "U1505" is displayed with DTC "U1000" or "U1507", first diagnose the DTC "U1000" or "U1507".

#### Is applicable DTC detected?

- YES >> Perform diagnosis of applicable.
- U1000: Refer to [DAS-65, "DTC Description"](#).
  - U1507: Refer to [DAS-76, "DTC Description"](#).
- NO >> GO TO 2.

#### 2. CHECK SIDE RADAR RH SELF DIAGNOSTIC RESULT

Check if any DTC is detected in "Self Diagnostic Result" mode of "SIDE RADAR RIGHT".

#### Is any DTC detected?

## U1505 SIDE RDR R CAN 2

< DTC/CIRCUIT DIAGNOSIS >

[ADAS CONTROL UNIT]

- YES >> Perform diagnosis on the detected DTC and repair or replace the malfunctioning parts. Refer to [DAS-129, "DTC Index"](#).
- NO >> Replace the ADAS control unit. Refer to [DAS-80, "Removal and Installation"](#).

A  
B  
C  
D  
E  
F  
G  
H  
I  
J  
K  
L  
M  
N  
P

DAS

**U1506 SIDE RDR R CAN 1**

**DTC Description**

INFOID:000000011953115

**DTC DETECTION LOGIC**

DTC No.	CONSULT screen terms (Trouble diagnosis content)	DTC detection condition	
U1506	SIDE RDR R CAN CIR 1 (Side radar right CAN circuit 1)	Diagnosis condition	When ignition switch is ON.
		Signal (terminal)	–
		Threshold	ADAS control unit detects an error signal that is received from side radar RH via ITS communication
		Diagnosis delay time	–

**POSSIBLE CAUSE**

Side radar RH

**FAIL-SAFE**

The following systems are canceled:

- Blind Spot Warning (BSW)
- Rear Cross Traffic Alert (RCTA)

**DTC CONFIRMATION PROCEDURE**

**1.CHECK DTC PRIORITY**

If DTC “U1506” is displayed with DTC “U1000” or “U1507”, first diagnose the DTC “U1000” or “U1507”.

Is applicable DTC detected?

- YES >> Perform diagnosis of applicable.
- U1000: Refer to [DAS-65, "DTC Description"](#).
  - U1507: Refer to [DAS-76, "DTC Description"](#).

NO >> GO TO 2.

**2.PERFORM DTC CONFIRMATION PROCEDURE**

**CONSULT**

1. Start the engine.
2. Turn the Blind Spot Warning system ON.
3. Select “All DTC Reading” mode.
4. Check if “U1506” is detected as the current malfunction in “Self Diagnostic Result” mode of “ICC/ADAS”.

Is “U1506” detected as the current malfunction?

- YES >> Refer to [DAS-74, "Diagnosis Procedure"](#).
- NO-1 >> To check malfunction symptom before repair: Refer to [GI-41, "Intermittent Incident"](#).
- NO-2 >> Confirmation after repair: Inspection End.

**Diagnosis Procedure**

INFOID:000000011953116

**1.CHECK DTC PRIORITY**

If DTC “U1506” is displayed with DTC “U1000” or “U1507”, first diagnose the DTC “U1000” or “U1507”.

Is applicable DTC detected?

- YES >> Perform diagnosis of applicable.
- U1000: Refer to [DAS-65, "DTC Description"](#).
  - U1507: Refer to [DAS-76, "DTC Description"](#).

NO >> GO TO 2.

**2.CHECK SIDE RADAR RH SELF DIAGNOSTIC RESULT**

Check if any DTC is detected in “Self Diagnostic Result” mode of “SIDE RADAR RIGHT”.

Is any DTC detected?

# U1506 SIDE RDR R CAN 1

< DTC/CIRCUIT DIAGNOSIS >

[ADAS CONTROL UNIT]

- YES >> Perform diagnosis on the detected DTC and repair or replace the malfunctioning parts. Refer to [DAS-129, "DTC Index"](#).
- NO >> Replace the ADAS control unit. Refer to [DAS-80, "Removal and Installation"](#).

A  
B  
C  
D  
E  
F  
G  
H  
I  
J  
K  
L  
M  
N  
P

DAS

# U1507 LOST COMM(SIDE RDR R)

< DTC/CIRCUIT DIAGNOSIS >

[ADAS CONTROL UNIT]

## U1507 LOST COMM(SIDE RDR R)

### DTC Description

INFOID:000000011953117

### DTC DETECTION LOGIC

DTC No.	CONSULT screen terms (Trouble diagnosis content)	DTC detection condition	
U1507	LOST COMM(SIDE RDR R) [Lost communication (side radar right)]	Diagnosis condition	When ignition switch is ON.
		Signal (terminal)	—
		Threshold	ADAS control unit cannot receive ITS communication signal from side radar RH
		Diagnosis delay time	2 seconds or more

### POSSIBLE CAUSE

- Side radar RH right/left switching signal circuit
- ITS communication system
- Side radar RH

### FAIL-SAFE

The following systems are canceled:

- Blind Spot Warning (BSW)
- Rear Cross Traffic Alert (RCTA)

### DTC CONFIRMATION PROCEDURE

#### 1. CHECK DTC PRIORITY

If DTC “U1507” is displayed with DTC “U1000”, first diagnose the DTC “U1000”.

#### Is applicable DTC detected?

- YES >> Perform diagnosis of applicable. Refer to [DAS-65, "DTC Description"](#).  
NO >> GO TO 2.

#### 2. PERFORM DTC CONFIRMATION PROCEDURE

##### CONSULT

1. Start the engine.
2. Turn the Blind Spot Warning system ON.
3. Select “All DTC Reading” mode.
4. Check if “U1507” is detected as the current malfunction in “Self Diagnostic Result” mode of “ICC/ADAS”.

#### Is “U1507” detected as the current malfunction?

- YES >> Refer to [DAS-76, "Diagnosis Procedure"](#).  
NO-1 >> To check malfunction symptom before repair: Refer to [GI-41, "Intermittent Incident"](#).  
NO-2 >> Confirmation after repair: Inspection End.

### Diagnosis Procedure

INFOID:000000011953118

#### 1. CHECK RIGHT/LEFT SWITCHING SIGNAL CIRCUIT

Check right/left switching signal circuit. Refer to [DAS-163, "Diagnosis Procedure"](#).

#### Is the inspection result normal?

- YES >> Perform the CAN communication system inspection. Repair or replace the malfunctioning parts.  
Refer to [LAN-17, "Trouble Diagnosis Flow Chart"](#).  
NO >> Repair right/left switching signal circuit.



# U1508 LOST COMM(SIDE RDR L)

< DTC/CIRCUIT DIAGNOSIS >

[ADAS CONTROL UNIT]

## U1508 LOST COMM(SIDE RDR L)

### DTC Description

INFOID:0000000011953119

### DTC DETECTION LOGIC

DTC No.	CONSULT screen terms (Trouble diagnosis content)	DTC detection condition	
U1508	LOST COMM(SIDE RDR L) [Lost communication (side radar left)]	Diagnosis condition	When ignition switch is ON.
		Signal (terminal)	–
		Threshold	ADAS control unit cannot receive ITS communication signal from side radar LH
		Diagnosis delay time	2 seconds or more

### POSSIBLE CAUSE

- Side radar LH harness connector
- ITS communication system
- Side radar LH

### FAIL-SAFE

The following systems are canceled:

- Blind Spot Warning (BSW)
- Rear Cross Traffic Alert (RCTA)

### DTC CONFIRMATION PROCEDURE

#### 1. CHECK DTC PRIORITY

If DTC “U1508” is displayed with DTC “U1000”, first diagnose the DTC “U1000”.

##### Is applicable DTC detected?

- YES >> Perform diagnosis of applicable. Refer to [DAS-65, "DTC Description"](#).  
 NO >> GO TO 2.

#### 2. PERFORM DTC CONFIRMATION PROCEDURE

##### CONSULT

1. Start the engine.
2. Turn the Blind Spot Warning system ON.
3. Select “All DTC Reading” mode.
4. Check if “U1508” is detected as the current malfunction in “Self Diagnostic Result” mode of “ICC/ADAS”.

##### Is “U1508” detected as the current malfunction?

- YES >> Refer to [DAS-77, "Diagnosis Procedure"](#).  
 NO-1 >> To check malfunction symptom before repair: Refer to [GI-41, "Intermittent Incident"](#).  
 NO-2 >> Confirmation after repair: Inspection End.

### Diagnosis Procedure

INFOID:0000000011953120

#### 1. CHECK DTC PRIORITY

If DTC “U1508” is displayed with DTC “U1000”, first diagnose the DTC “U1000”.

##### Is applicable DTC detected?

- YES >> Perform diagnosis of applicable. Refer to [DAS-65, "DTC Description"](#).  
 NO >> GO TO 2.

#### 2. CHECK SIDE RADAR HARNESS CONNECTOR

1. Turn the ignition switch OFF.
2. Check the terminals and connectors of the side radar LH for damage, bend and short (unit side and connector side).

##### Is the inspection result normal?

A  
B  
C  
D  
E  
F  
G  
H  
I  
J  
K  
L  
M  
N  
P

DAS

## U1508 LOST COMM(SIDE RDR L)

< DTC/CIRCUIT DIAGNOSIS >

[ADAS CONTROL UNIT]

- 
- YES >> Perform the CAN communication system inspection. Repair or replace the malfunctioning parts.  
Refer to [LAN-17, "Trouble Diagnosis Flow Chart"](#).
- NO >> Repair the terminal or connector.

# POWER SUPPLY AND GROUND CIRCUIT

< DTC/CIRCUIT DIAGNOSIS >

[ADAS CONTROL UNIT]

## POWER SUPPLY AND GROUND CIRCUIT

### Diagnosis Procedure

INFOID:0000000011953121

Regarding Wiring Diagram information, refer to [DAS-27. "Wiring Diagram"](#).

### 1. CHECK FUSES

Check that the following fuse is not blown:

Signal name	Fuse No.
Ignition power supply	30 (10 A)

Is the fuse blown?

- YES >> Replace the blown fuse after repairing the affected circuit.  
NO >> GO TO 2.

### 2. CHECK ADAS CONTROL UNIT POWER SUPPLY CIRCUIT

Check voltage between ADAS control unit harness connector and ground.

Terminal		Condition	Voltage (Approx.)
(+)	(-)		
ADAS control unit		Ignition switch	0 V
Connector	Terminal		
B89	3	OFF	Battery voltage
		ON	

Is the inspection result normal?

- YES >> GO TO 3.  
NO >> Repair the ADAS control unit power supply circuit.

### 3. CHECK ADAS CONTROL UNIT GROUND CIRCUIT

1. Turn the ignition switch OFF.
2. Disconnect the ADAS control unit connector.
3. Check for continuity between ADAS control unit harness connector and ground.

ADAS control unit		Ground	Continuity
Connector	Terminal		
B89	1		Yes

Is the inspection result normal?

- YES >> Inspection End.  
NO >> Repair the ADAS control unit ground circuit.

A  
B  
C  
D  
E  
F  
G  
H  
I  
J  
K  
L  
M  
N  
P

## REMOVAL AND INSTALLATION

### ADAS CONTROL UNIT

#### Removal and Installation

INFOID:000000011953122

#### REMOVAL

**NOTE:**

Before replacing ADAS control unit, perform “Before Replace ECU” of “Read / Write Configuration” to save or print current vehicle specification. Refer to [DAS-36, "Description"](#).

1. Remove trunk side finisher (LH). Refer to [INT-52, "TRUNK SIDE FINISHER : Removal and Installation"](#).
2. Remove nuts (A) from ADAS control unit bracket.

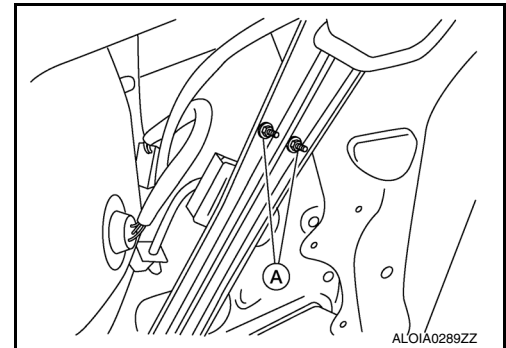

3. Disconnect harness connector from ADAS control unit and remove ADAS control unit from vehicle.

#### INSTALLATION

Installation is in the reverse order of removal.

**CAUTION:**

Be sure to perform “After Replace ECU” of “Read / Write Configuration” or “Manual Configuration” when replacing ADAS control unit. Refer to [DAS-36, "Description"](#).

**CAUTION:**

Be sure to perform “Configuration (ADAS control unit)” when replacing ADAS control unit. Refer to [DAS-36, "Description"](#).

< PRECAUTION >

# PRECAUTION

## PRECAUTIONS

### Precaution for Supplemental Restraint System (SRS) "AIR BAG" and "SEAT BELT PRE-TENSIONER"

INFOID:000000011953123

The Supplemental Restraint System such as "AIR BAG" and "SEAT BELT PRE-TENSIONER", used along with a front seat belt, helps to reduce the risk or severity of injury to the driver and front passenger for certain types of collision. Information necessary to service the system safely is included in the SR and SB section of this Service Manual.

**WARNING:**

- To avoid rendering the SRS inoperative, which could increase the risk of personal injury or death in the event of a collision which would result in air bag inflation, all maintenance must be performed by an authorized NISSAN/INFINITI dealer.
- Improper maintenance, including incorrect removal and installation of the SRS, can lead to personal injury caused by unintentional activation of the system. For removal of Spiral Cable and Air Bag Module, see the SR section.
- Do not use electrical test equipment on any circuit related to the SRS unless instructed to in this Service Manual. SRS wiring harnesses can be identified by yellow and/or orange harnesses or harness connectors.

### PRECAUTIONS WHEN USING POWER TOOLS (AIR OR ELECTRIC) AND HAMMERS

**WARNING:**

- When working near the Airbag Diagnosis Sensor Unit or other Airbag System sensors with the Ignition ON or engine running, DO NOT use air or electric power tools or strike near the sensor(s) with a hammer. Heavy vibration could activate the sensor(s) and deploy the air bag(s), possibly causing serious injury.
- When using air or electric power tools or hammers, always switch the Ignition OFF, disconnect the battery and wait at least three minutes before performing any service.

### Precaution for Work

INFOID:000000012462942

- When removing or disassembling each component, be careful not to damage or deform it. If a component may be subject to interference, be sure to protect it with a shop cloth.
- When removing (disengaging) components with a screwdriver or similar tool, be sure to wrap the component with a shop cloth or vinyl tape to protect it.
- Protect the removed parts with a shop cloth and prevent them from being dropped.
- Replace a deformed or damaged clip.
- If a part is specified as a non-reusable part, always replace it with a new one.
- Be sure to tighten bolts and nuts securely to the specified torque.
- After installation is complete, be sure to check that each part works properly.
- Follow the steps below to clean components:
  - Water soluble dirt:
    - Dip a soft cloth into lukewarm water, wring the water out of the cloth and wipe the dirty area.
    - Then rub with a soft, dry cloth.
  - Oily dirt:
    - Dip a soft cloth into lukewarm water with mild detergent (concentration: within 2 to 3%) and wipe the dirty area.
    - Then dip a cloth into fresh water, wring the water out of the cloth and wipe the detergent off.
    - Then rub with a soft, dry cloth.
  - Do not use organic solvent such as thinner, benzene, alcohol or gasoline.
  - For genuine leather seats, use a genuine leather seat cleaner.

### Precautions For Harness Repair

INFOID:000000011953124

ITS communication uses a twisted pair line. Be careful when repairing it.

A  
B  
C  
D  
E  
F  
G  
H  
I  
J  
K  
L  
M  
N  
P



# PRECAUTIONS

## [DRIVER ASSISTANCE SYSTEM]

### < PRECAUTION >

- Solder the repaired area and wrap tape around the soldered area.

**NOTE:**

A fray of twisted lines must be within 110 mm (4.33 in).

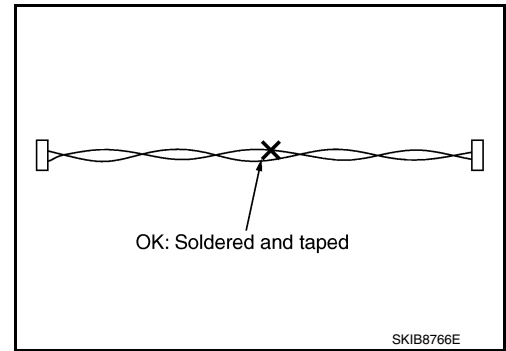

- Bypass connection is never allowed at the repaired area.

**NOTE:**

Bypass connection may cause ITS communication error. The spliced wire becomes separated and the characteristics of twisted line are lost.

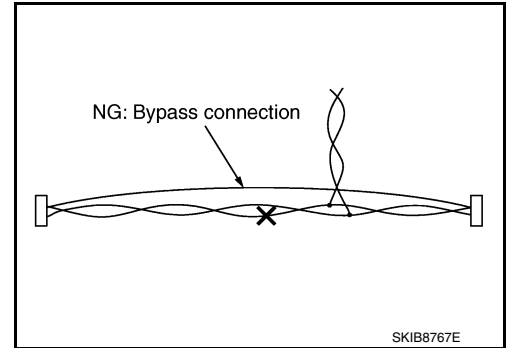

## ICC System Service

INFOID:000000011953125

**CAUTION:**

- Turn **MAIN** switch OFF in conditions similar to driving, such as free rollers or a chassis dynamometer.
- Do not use ICC sensor removed from vehicle. Never disassemble or remodel.
- Erase DTC when replacing parts of ICC system, then check operation of ICC system after adjusting radar alignment if necessary.

## FEB System Service

INFOID:000000011953126

**CAUTION:**

- Turn FEB system OFF in conditions similar to driving, such as free rollers or a chassis dynamometer.
- Do not use ICC sensor removed from vehicle. Never disassemble or remodel.
- Erase DTC when replacing parts of ICC system, then check operation of ICC system after radar alignment if necessary.
- Do not change FEB initial state ON⇒OFF without consent of the customer.

## Blind Spot Warning System Service

INFOID:000000011953127

**CAUTION:**

- Do not use Blind Spot Warning/ Rear Cross Traffic Alert (RCTA) system when driving with free rollers or a chassis dynamometer.
- Do not perform active test while driving.

TO KEEP BLIND SPOT WARNING/Rear Cross Traffic Alert (RCTA) SYSTEM OPERATING PROPERLY, BE SURE TO OBSERVE THE FOLLOWING ITEMS:

### System Maintenance

Side radars for Blind Spot Warning and Rear Cross Traffic Alert (RCTA) system are located near rear bumper.

- Be sure to keep the area near the side radars clean.
- Do not attach stickers (including transparent material), install accessories or apply additional paint near side radars.
- Do not strike or damage area around side radars.

< PREPARATION >

# PREPARATION

## PREPARATION

### Special Service Tools

INFOID:0000000012324748

The actual shape of the tools may differ from those illustrated here.

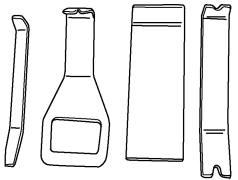
Tool number (TechMate No.) Tool name	Description
<p>— (J-46534) Trim Tool Set</p>  <p>AWJIA0483ZZ</p>	<p>Removing trim components</p>

A  
B  
C  
D  
E  
F  
G  
H  
I  
J  
K  
L  
M  
N  
P

DAS

## SYSTEM DESCRIPTION

### COMPONENT PARTS

#### Component Parts Location

INFOID:000000011953128

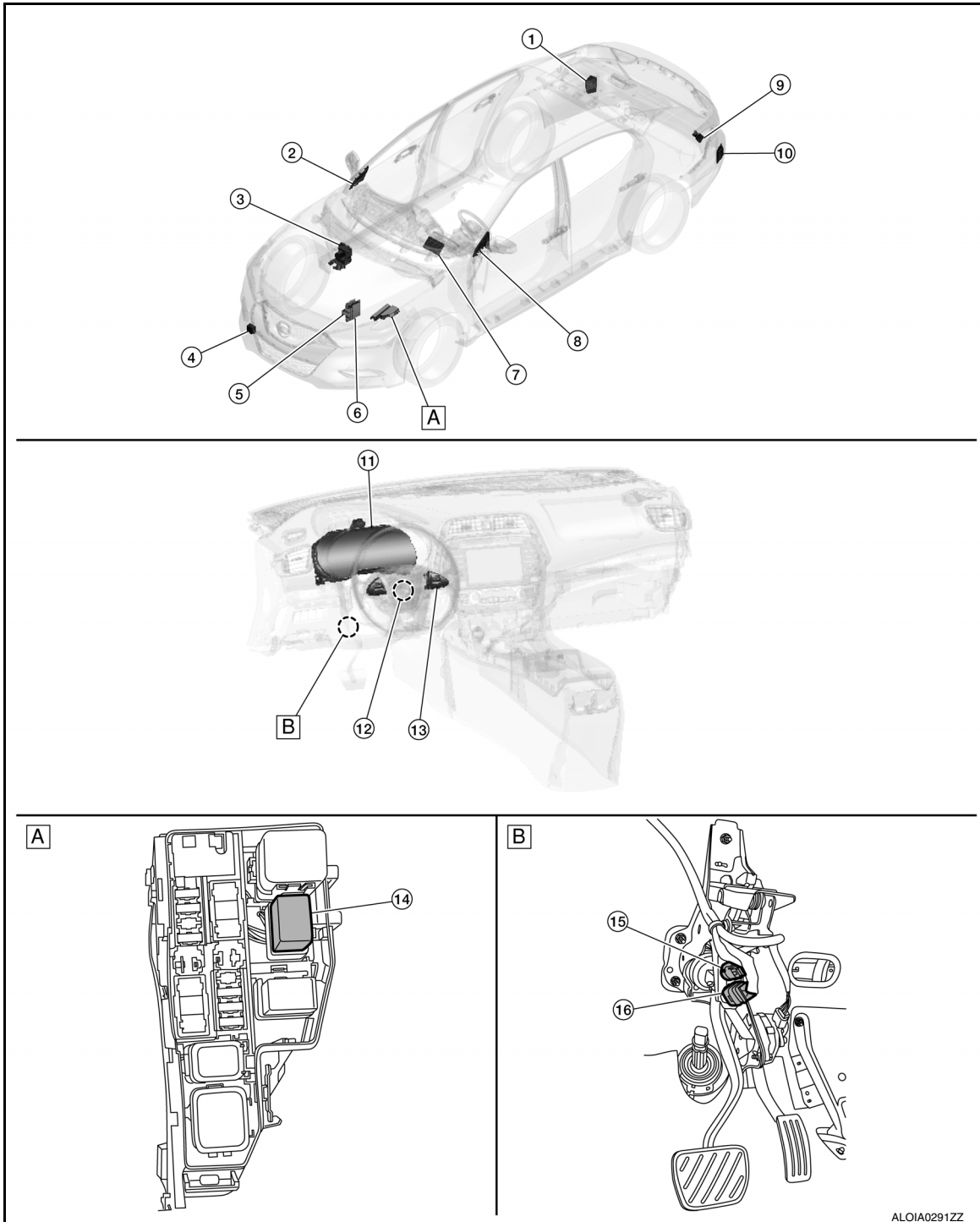

A. View with fuse, fusible link and relay B. Upper side of brake pedal assembly box cover removed



# COMPONENT PARTS

< SYSTEM DESCRIPTION >

[DRIVER ASSISTANCE SYSTEM]

No.	Component	Description
1.	Side radar RH	Refer to <a href="#">DAS-87, "Side Radar LH/RH"</a> .
2.	Blind Spot Warning indicator RH	Refer to <a href="#">DAS-87, "Blind Spot Warning Indicator LH/RH"</a> .
3.	ABS actuator and electric unit (control unit)	<ul style="list-style-type: none"> <li>• ABS actuator and electric unit (control unit) transmits the vehicle speed signal (wheel speed), stop lamp signal and VDC/TCS/ABS system operation condition to ADAS control unit via CAN communication.</li> <li>• ABS actuator and electric unit (control unit) controls the brake, based on a brake fluid pressure control signal received from ADAS control unit via CAN communication.</li> <li>• Refer to <a href="#">BRC-168, "Removal and Installation"</a> for detailed installation location.</li> </ul>
4.	ICC sensor	Refer to <a href="#">DAS-85, "ICC Sensor"</a> .
5.	TCM	<ul style="list-style-type: none"> <li>• TCM transmits the signal related to CVT control to ADAS control unit.</li> <li>• Refer to <a href="#">TM-12, "CVT CONTROL SYSTEM : Component Parts Location"</a> for detailed installation location.</li> </ul>
6.	ECM	<ul style="list-style-type: none"> <li>• Transmits the ICC brake switch signal, stop lamp switch signal, ICC steering switch signal, etc., to ADAS control unit via CAN communication.</li> <li>• Refer to <a href="#">EC-15, "ENGINE CONTROL SYSTEM : Component Parts Location"</a> for detailed installation location.</li> </ul>
7.	BCM	<ul style="list-style-type: none"> <li>• Transmits the turn indicator signal and position light request signal to ADAS control unit via CAN communication.</li> <li>• Refer to <a href="#">BCS-5, "BODY CONTROL SYSTEM : Component Parts Location"</a> for detailed installation location.</li> </ul>
8.	Blind Spot Warning indicator LH	Refer to <a href="#">DAS-87, "Blind Spot Warning Indicator LH/RH"</a> .
9.	ADAS control unit	<ul style="list-style-type: none"> <li>• ADAS control unit controls each system (ICC/PFCW/FEB/BSW/RCTA), based on ITS communication signals and CAN communication signals from each control unit.</li> <li>• ADAS control unit transmits engine torque command value, brake fluid pressure control signal, and buzzer output signal to each unit.</li> </ul>
10.	Side radar LH	Refer to <a href="#">DAS-87, "Side Radar LH/RH"</a> .
11.	Combination meter	<ul style="list-style-type: none"> <li>• Description: <a href="#">DAS-86, "Combination Meter"</a>.</li> <li>• Refer to <a href="#">MWI-68, "Removal and Installation"</a> for detailed installation location.</li> </ul>
12.	Steering angle sensor	<ul style="list-style-type: none"> <li>• Measures the rotation amount, rotation speed, and rotation direction of steering wheel and then transmits them to ADAS control unit via CAN communication.</li> <li>• Refer to <a href="#">BRC-10, "Component Parts Location"</a> for detailed installation location.</li> </ul>
13.	ICC steering switch	Refer to <a href="#">DAS-85, "ICC Steering Switch"</a> .
14.	ICC brake hold relay	Refer to <a href="#">DAS-86, "ICC Brake Hold Relay"</a> .
15.	Brake pedal position switch	Refer to <a href="#">DAS-86, "Brake Pedal Position Switch / Stop Lamp Switch"</a> .
16.	Stop lamp switch	

## ICC Sensor

INFOID:000000011953129

- ICC sensor is installed behind the front bumper and detects a vehicle ahead using millimeter waves.
- ICC sensor detects radar reflected from a vehicle ahead by irradiating radar forward and calculates a distance from the vehicle ahead and relative speed, based on the detected signal.
- ICC sensor transmits the presence/absence of a vehicle ahead and the distance from the vehicle to ADAS control unit via ITS communication.

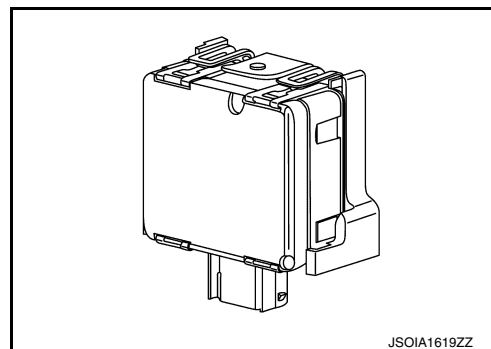

## ICC Steering Switch

INFOID:000000011953130

- ICC steering switch is installed to the steering wheel and allows the driver to operate the ICC system using this switch.

# COMPONENT PARTS

## [DRIVER ASSISTANCE SYSTEM]

### < SYSTEM DESCRIPTION >

- ICC steering switch allows the ON/OFF of the Intelligent Cruise Control and the settings of a vehicle speed and distance between vehicles.
- ICC steering switch signal is transmitted to ECM. ECM transmits the signal to the ADAS control unit via CAN communication.

### Brake Pedal Position Switch / Stop Lamp Switch

INFOID:000000011953131

- Brake pedal position switch is installed at the upper part of the brake pedal and detects a brake operation performed by the driver.
- Brake pedal position switch is turned OFF when depressing the brake pedal.
- Brake pedal position switch signal is input to ECM. Brake pedal position switch signal is transmitted from ECM to ADAS control unit via CAN communication.

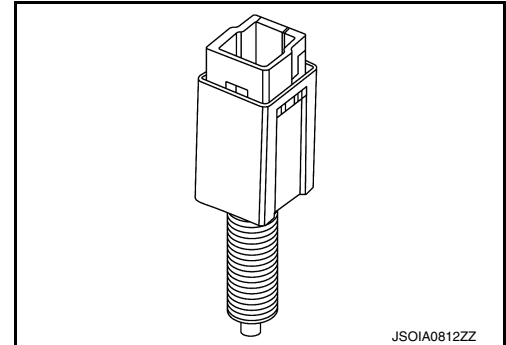

- Stop lamp switch is installed at the upper part of the brake pedal and detects a brake operation performed by the driver.
- Stop lamp switch is turned ON when depressing the brake pedal.
- Stop lamp switch signal is input to ECM and ABS actuator and electric unit (control unit). Stop lamp switch signals are transmitted from ECM and ABS actuator and electric unit (control unit) to ADAS control unit via CAN communication.

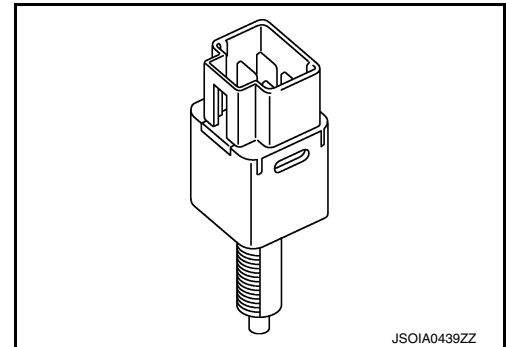

### ICC Brake Hold Relay

INFOID:000000011953132

- ICC brake hold relay is installed in the fuse, fusible link and relay box.
- When the brake is activated by the ICC system, the ICC brake hold relay turns ON the stop lamp by bypassing the circuit of the stop lamp according to a signal transmitted from the ADAS control unit.

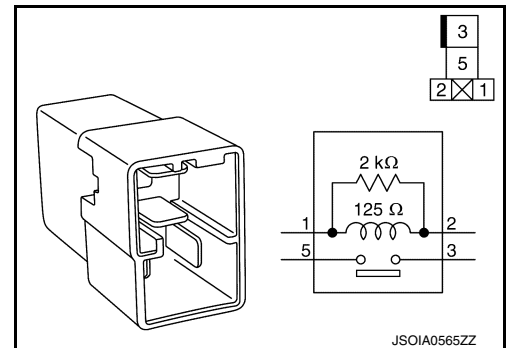

### Combination Meter

INFOID:000000011953133

- Receives meter display signal from ADAS control unit via CAN communication.
- Displays the system status according to a signal received from the ADAS control unit.
- Receives a buzzer output signal via CAN communication and sounds the buzzer.

# COMPONENT PARTS

< SYSTEM DESCRIPTION >

[DRIVER ASSISTANCE SYSTEM]

## Side Radar LH/RH

INFOID:0000000011953135

- Installed near the rear bumper, the side radar detects other vehicles beside own vehicle in an adjacent lane.
- Connected with the ADAS control unit via ITS communication, the side radar transmits a vehicle detection signal.
- Receives a Blind Spot Warning indicator signal and a Blind Spot Warning indicator dimmer signal from the ADAS control unit and transmits an indicator operation signal to the Blind Spot Warning indicator LH/RH.
- Since side radar RH and side radar LH have the same specifications, side radar RH has the right/left switching signal circuit for identification.

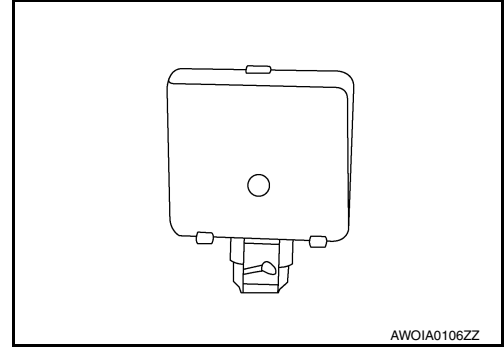

## Blind Spot Warning Indicator LH/RH

INFOID:0000000011953136

- Installed on the front door corner cover, the Blind Spot Warning indicator warns the driver by lighting/blinking.
- Receives a Blind Spot Warning indicator operation signal from the side radar LH/RH and blinks or turns ON/OFF the Blind Spot Warning indicator.

A  
B  
C  
D  
E  
F  
G  
H  
I  
J  
K  
L  
M  
N  
P

DAS

SYSTEM

PFCW

PFCW : System Description

INFOID:000000011953137

SYSTEM DIAGRAM

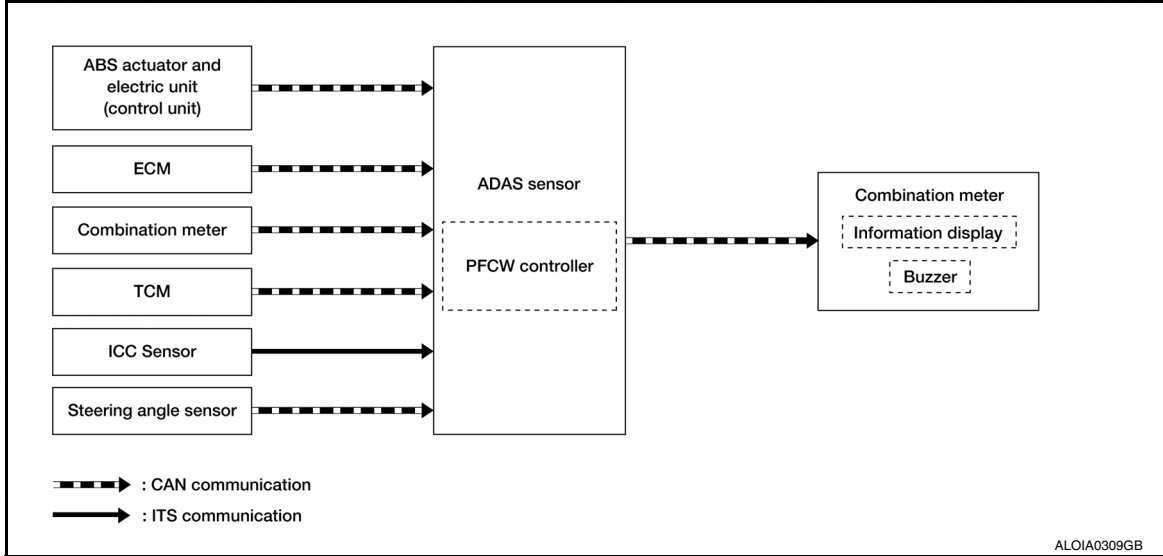

ADAS CONTROL UNIT INPUT/OUTPUT SIGNAL ITEM

Input Signal Item

Transmit unit		Signal name	Description
ABS actuator and electric unit (control unit)	CAN communication	ABS malfunction signal	Receives a malfunction state of ABS.
		ABS operation signal	Receives an operational state of ABS.
		ABS warning lamp signal	Receives an operational state of ABS warning lamp.
		TCS malfunction signal	Receives a malfunction state of TCS.
		TCS operation signal	Receives an operational state of TCS.
		VDC OFF switch signal	Receives an ON/OFF state of VDC.
		VDC malfunction signal	Receives a malfunction state of VDC.
		VDC operation signal	Receives an operational state of VDC.
		Vehicle speed signal (ABS)	Receives wheel speeds of front wheels.
		Yaw rate signal	Receives yaw rate acting on the vehicle.
		Stop lamp switch	Receives stop lamp switch state.
ECM	CAN communication	Engine speed signal	Receives engine speed.
		Stop lamp switch signal	Receives an operational state of the brake pedal.
		Brake pedal position switch signal	Receives an operational state of the brake pedal.
Combination meter	CAN communication	System selection signal	Receives a selection state of each item in "Driver Aids" selected with the integral switch.
ICC sensor	ITS communication	ICC sensor signal	Receives detection results, such as the presence or absence of a leading vehicle and distance from the vehicle.
TCM	CAN communication	Input speed signal	Receives the number of revolutions of input shaft.
		Shift position signal	Receives a selector lever position.
		Current gear position signal	Receives a current gear position.
		Output shaft revolution signal	Receives the number of revolutions of output shaft.

# SYSTEM

< SYSTEM DESCRIPTION >

[DRIVER ASSISTANCE SYSTEM]

Transmit unit	Signal name		Description
Steering angle sensor	CAN communication	Steering angle sensor malfunction signal	Receives a malfunction state of steering angle sensor.
		Steering angle sensor signal	Receives the number of revolutions and turning direction of the steering wheel.
		Steering angle speed signal	Receives the turning angle speed of the steering wheel.

## Output Signal Item

Reception unit	Signal name		Description
Combination meter	CAN communication	Meter display signal	Vehicle ahead detection indicator signal Transmits a signal to display a state of the system on the combination meter.
		PFCW/FEB system indicator signal	Transmits a signal to turn ON the PFCW/FEB system indicator.
	Buzzer output signal		Transmits a buzzer output signal to activate the buzzer.
ICC sensor	ITS communication	Vehicle speed signal	Transmits a vehicle speed calculated by the ADAS control unit.

## DESCRIPTION

- The PFCW system will function when own vehicle is driven at speeds of approximately 3 MPH (5 km/h) and above.
- The Predictive Forward Collision Warning (PFCW) system alerts the driver by the vehicle ahead detection indicator and chime when the distance between own vehicle and a vehicle in front of the vehicle ahead becomes closer.

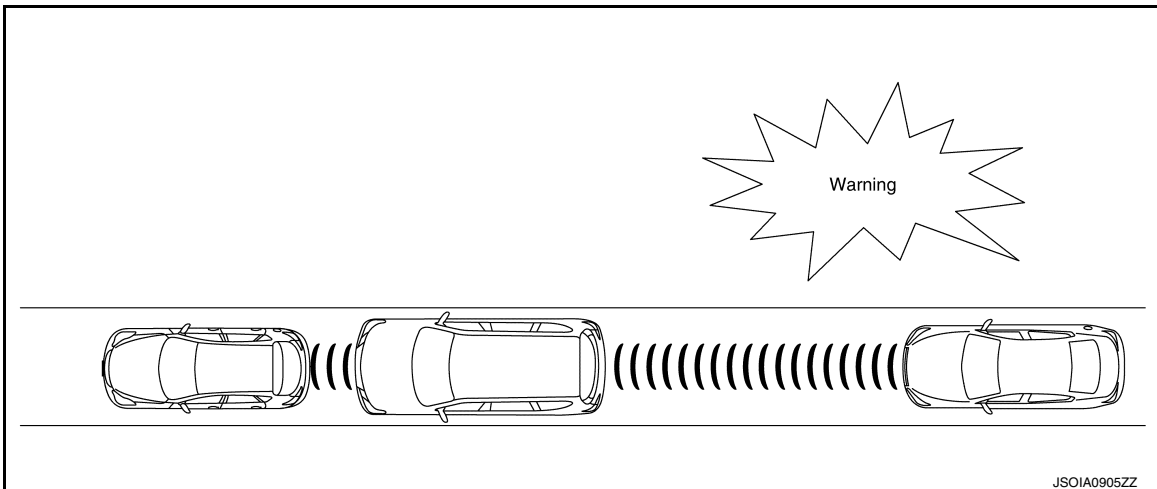

### NOTE:

The PFCW/FEB system shares the diagnosis function with ICC system.

## FUNCTION DESCRIPTION

The distance from the vehicle in front of the vehicle ahead and a relative speed are calculated using the ICC sensor, and an ICC sensor signal is transmitted to the ADAS control unit via ITS communication. When judging the necessity of warning according to the received ICC sensor signal, the ADAS control unit transmits a warning buzzer signal and meter display signal to the combination meter via CAN communication.

### PFCW Operating Condition

- PFCW/FEB system display (white): ON
- Vehicle speed: Approximately 3 MPH (5 km/h) and above
- Vehicle in front of the vehicle ahead: Detected

### NOTE:

ON/OFF of PFCW/FEB system is performed with the integral switch of the combination meter information display.

## BSW

A  
B  
C  
D  
E  
F  
G  
H  
I  
J  
K  
L  
M  
N

DAS

P

# SYSTEM

< SYSTEM DESCRIPTION >

[DRIVER ASSISTANCE SYSTEM]

## BSW : System Description

INFOID:000000011953138

### SYSTEM DIAGRAM

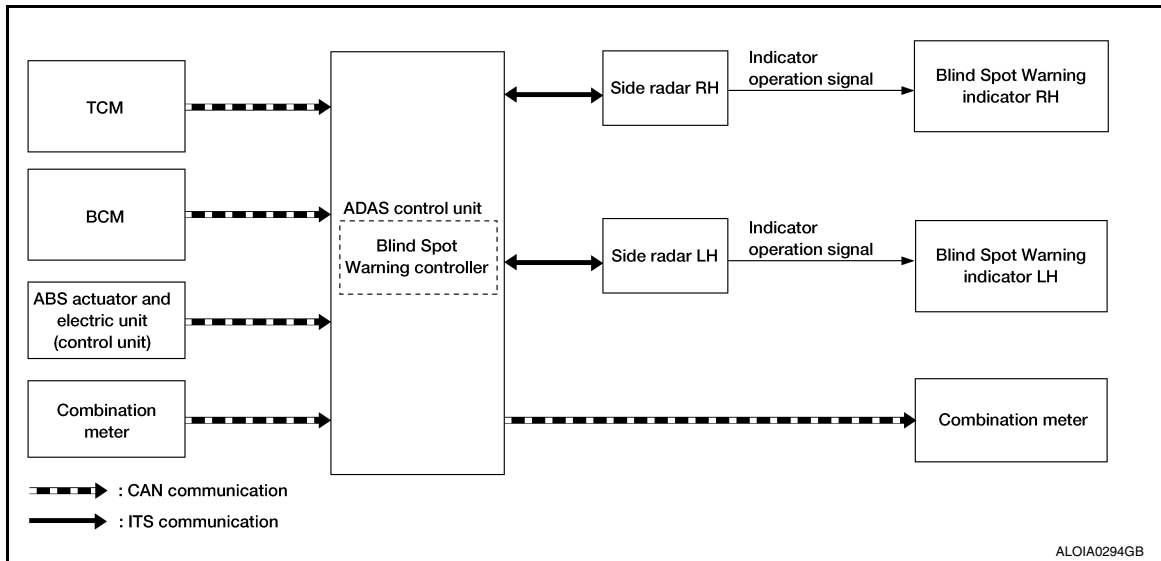

### ADAS CONTROL UNIT INPUT/OUTPUT SIGNAL ITEM

ADAS control unit receives signals via CAN communication. It also detects vehicle conditions that are necessary for Blind Spot Warning control.

#### Input Signal Item

Transmit unit	Signal name		Description
TCM	CAN communication	Shift position signal	Receives a selector lever position.
ABS actuator and electric unit (control unit)	CAN communication	Vehicle speed signal (ABS)	Receives wheel speeds of four wheels.
BCM	CAN communication	Turn indicator signal	Receives an operational state of the turn signal lamp and the hazard lamp.
		Dimmer signal	Receives ON/OFF state of dimmer signal.
Combination meter	CAN communication	System selection signal	Receives a selection state of each item in "Driver Aids" selected with the integral switch.
Side radar LH, RH	ITS communication	Vehicle detection signal	Receives vehicle detection condition of detection zone.

#### Output Signal Item

Reception unit	Signal name		Description
Combination meter	CAN communication	BSW indicator signal	Transmits a BSW indicator signal to turn ON the BSW indicator on the combination meter.
		Buzzer output signal	Transmits a buzzer output signal to activate the buzzer.
Side radar LH, RH	ITS communication	Blind Spot Warning indicator signal	Transmits a Blind Spot Warning indicator signal to turn ON the Blind Spot Warning indicator.
		Blind Spot Warning indicator dimmer signal	Transmits a Blind Spot Warning indicator dimmer signal to dim Blind Spot Warning indicator.
		Vehicle speed signal	Transmits a vehicle speed that is calculated by the ADAS control unit.

### FUNCTION DESCRIPTION

- The BSW system can help alert the driver of other vehicles in adjacent lanes when changing lanes.
- The BSW system uses side radars installed near the rear bumper to detect vehicles in an adjacent lane.
- The side radars can detect vehicles on either side of vehicle within the detection zone shown as illustrated.

# SYSTEM

## [DRIVER ASSISTANCE SYSTEM]

### < SYSTEM DESCRIPTION >

- This detection zone starts from the outside mirror of vehicle and extends approximately 10 ft. (3.0 m) behind the rear bumper, and approximately 10 ft. (3.0 m) sideways.
- The BSW system operates above approximately 20 MPH (32 km/h).
- If the side radar detects vehicles in the detection zone, the Blind Spot Warning indicator illuminates.

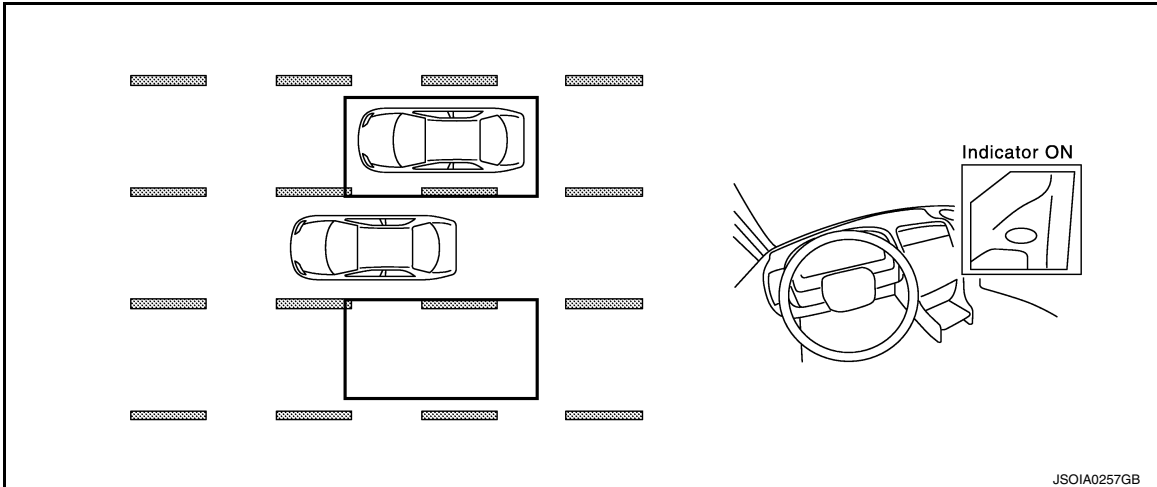

- If the driver then activates the turn signal, a buzzer will sound twice and the Blind Spot Warning indicator will blink.

#### NOTE:

A buzzer sounds if the side radar has detected a vehicle when the driver activates the turn signal. If a vehicle comes into the detection zone after the driver activates the turn signal, then only the Blind Spot Warning indicator blinks and no buzzer sounds.

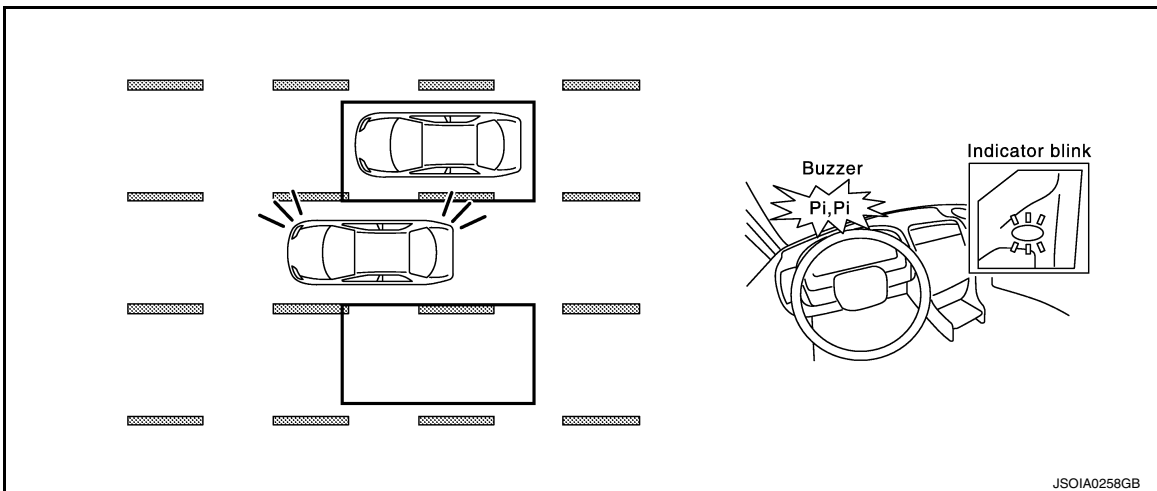

### BLIND SPOT WARNING SYSTEM OPERATION DESCRIPTION

- ADAS control unit enables BSW system.
- The ADAS control unit turns on the BSW system when it is turned ON by the integral switch.
- Side radar detects a vehicle in the adjacent lane and transmits the vehicle detection signal to ADAS control unit via ITS communication.
- ADAS control unit starts the control as follows, based on a vehicle detection signal, turn signal and dimmer signal transmitted from BCM via CAN communication:
  - Blind Spot Warning indicator signal and Blind Spot Warning indicator dimmer signal transmission to side radar.
- Side radar transmits an indicator operation signal to the Blind Spot Warning indicator according to Blind Spot Warning indicator signal and Blind Spot Warning indicator dimmer signal.

### OPERATING CONDITION

- Blind Spot Warning system display (white): ON
- Vehicle speed: Approximately 20 MPH (32 km/h) or more

#### NOTE:

ON/OFF of Blind Spot Warning system is performed with the integral switch.

- After the operating conditions of warning are satisfied, the warning continues until the vehicle speed reaches approximately 18 MPH (29 km/h).

# SYSTEM

## [DRIVER ASSISTANCE SYSTEM]

### < SYSTEM DESCRIPTION >

- The Blind Spot Warning system may not function properly, depending on the situation. Refer to [DAS-82. "Blind Spot Warning System Service"](#).

### RCTA

### RCTA : System Description

INFOID:000000011953139

### SYSTEM DIAGRAM

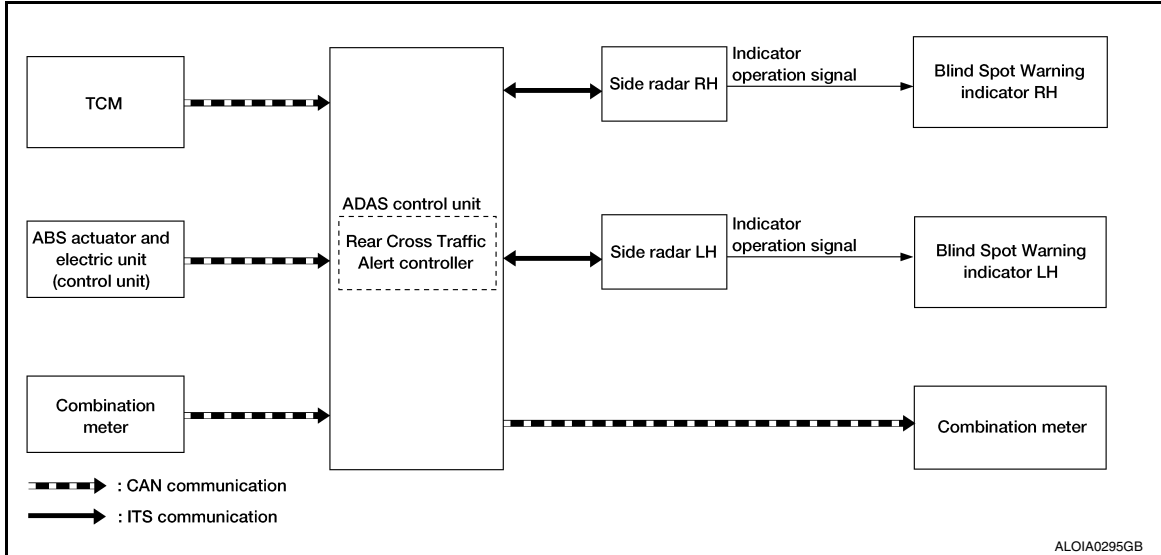

### ADAS CONTROL UNIT INPUT/OUTPUT SIGNAL ITEM

#### Input Signal Item

Transmit unit	Signal name		Description
TCM	CAN communication	Current gear position signal	Receives a current gear position.
		Shift selector position signal	Receives a shift selector position.
ABS actuator and electric unit (control unit)	CAN communication	ABS malfunction signal	Receives a malfunction state of ABS.
		VDC malfunction signal	Receives a malfunction state of VDC.
		Vehicle speed signal (ABS)	Receives wheel speeds of four wheels.
Combination meter	CAN communication	System selection signal	Receives a selection state of each item in "Driver Aids" selected with the integral switch.
Side radar LH, RH	ITS communication	Vehicle detection signal	Receives vehicle detection condition of detection zone.

#### Output Signal Item

Reception unit	Signal name		Description
Combination meter	CAN communication	BSW indicator signal	Transmits a BSW indicator signal to turn ON the BSW indicator on the combination meter.
		Buzzer output signal	Transmits a buzzer output signal to activate the buzzer.
Side radar LH, RH	ITS communication	Blind Spot Warning indicator signal	Transmits a Blind Spot Warning indicator signal to turn ON the Blind Spot Warning indicator.
		Blind Spot Warning indicator dimmer signal	Transmits a Blind Spot Warning indicator dimmer signal to dim Blind Spot Warning indicator.
		Vehicle speed signal	Transmits a vehicle speed calculated by the ADAS control unit.

### FUNCTION DESCRIPTION

- The Rear Cross Traffic Alert system can help alert the driver of approaching vehicles when the driver is backing out of a parking space.
- The RCTA system uses side radars installed near the rear bumper to detect approaching vehicles.



# SYSTEM

## < SYSTEM DESCRIPTION >

## [DRIVER ASSISTANCE SYSTEM]

- The RCTA system operates at speeds below 5 MPH (8 km/h) whenever the vehicle is in reverse.
- The side radar can detect vehicles on either side of vehicle within the detection zone shown as illustrated.
- The radar sensors detect the approaching vehicle from up to approximately 66 ft (20 m) away.

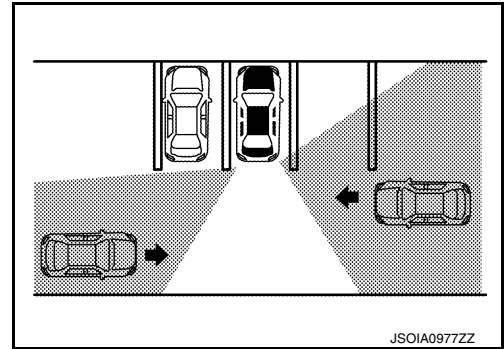

- If the radar detects a vehicle approaching from the side, the system gives visual and audible warning.

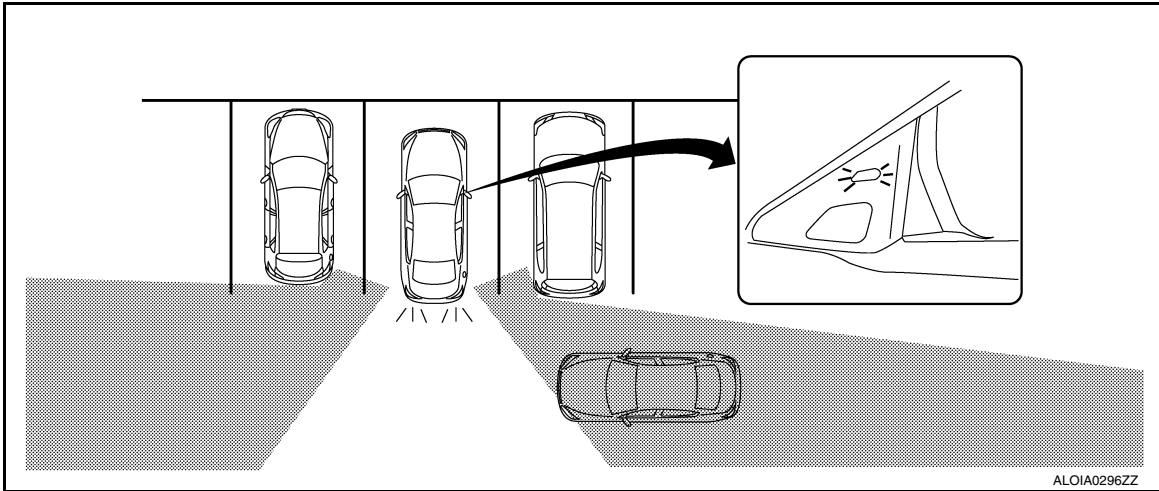

- If the side radar detects an approaching vehicle from the side, the RCTA system sounds a beep (single beep) and the Blind Spot Warning indicator on the side of the approaching vehicle flashes.

### REAR CROSS TRAFFIC ALERT SYSTEM OPERATION DESCRIPTION

- ADAS control unit enables Rear Cross Traffic Alert system
- The ADAS control unit turns ON the RCTA system when the BSW system is turned ON by the integral switch.
- ADAS control unit starts the control as follows, based on a reverse gear signal and vehicle detection signal.
- Side radar detects a vehicle approaching and transmits the vehicle detection signal to ADAS control unit via ITS communication.

#### Operation Condition of Rear Cross Traffic Alert System

ADAS control unit performs the control when the following conditions are satisfied:

- BSW system: ON (Selected by integral switch)
- When the vehicle is moving in reverse at 5 MPH (8 km/h) or less

### Fail-safe (ADAS Control Unit)

INFOID:000000011953140

If a malfunction occurs in each system, ADAS control unit cancels each control, sounds a beep, and turns ON the warning or indicator lamp.

System	Buzzer	Warning lamp/Warning display	Description
Intelligent Cruise Control (ICC)	High-pitched tone	ICC system warning	Cancel
Forward Emergency Braking (FEB)	High-pitched tone	FEB warning lamp (Yellow)	Cancel
Predictive Forward Collision Warning (PFCW)	High-pitched tone	FEB warning lamp (Yellow)	Cancel

# SYSTEM

< SYSTEM DESCRIPTION >

[DRIVER ASSISTANCE SYSTEM]

System	Buzzer	Warning lamp/Warning display	Description
Blind Spot Warning (BSW)	Low-pitched tone	BSW system warning	Cancel
Rear Cross Traffic Alert (RCTA)	—	BSW system warning	Cancel

## Fail-safe

INFOID:0000000011953141

If a malfunction occurs in the ICC sensor, ADAS control unit cancels control, sounds a beep, and turns ON the ICC system warning lamp in the combination meter.

## Fail-safe (Side Radar)

INFOID:0000000011953142

## FAIL-SAFE CONTROL BY DTC

Blind Spot Warning (BSW)/Rear Cross Traffic Alert (RCTA)

If a malfunction occurs in the side radar, ADAS control unit cancels control and turns ON the Blind Spot Warning indicator (orange) on the combination meter.

## TEMPORARY DISABLED STATUS AT BLOCKAGE

Blind Spot Warning (BSW)

When the side radar is blocked, the operation is temporarily canceled. Then the buzzer sounds and the Blind Spot Warning indicator (orange) is turned ON in the combination meter. Also, under the following conditions, the operation may be temporarily canceled:

- The side radar may be blocked by temporary ambient conditions such as splashing water, mist or fog.
- The blocked condition may also be caused by objects such as ice, frost or dirt obstructing the side radar.

Rear Cross Traffic Alert (RCTA)

When the side radar is blocked, the operation is temporarily canceled. Then the buzzer sounds and the Blind Spot Warning indicator (orange) is turned ON in the combination meter. Also, under the following conditions, the operation may be temporarily canceled.

- The side radar may be blocked by temporary ambient conditions such as splashing water, mist or fog.
- The blocked condition may also be caused by objects such as ice, frost or dirt obstructing the side radar.

# OPERATION

[DRIVER ASSISTANCE SYSTEM]

< SYSTEM DESCRIPTION >

## OPERATION

PFCW/FEB, BSW/RCTA

PFCW/FEB, BSW/RCTA : Switch Name and Function

INFOID:0000000011953143

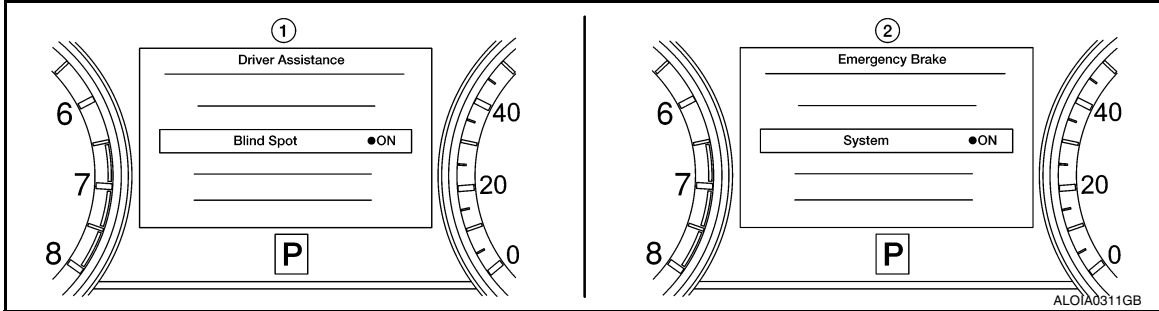

No.	Switch name	Description
1.	BSW/RCTA system setting screen (Integral switch settings screen)	The setting of BSW/RCTA system can be switched between ON and OFF on the combination meter information display. <b>NOTE:</b> When the Blind Spot Warning system is turned ON or OFF, the Rear Cross Traffic Alert system is turned ON or OFF simultaneously.
2.	PFCW/FEB system setting screen (Integral switch settings screen)	The setting of PFCW/FEB system can be switched between ON and OFF on the combination meter information display. <b>NOTE:</b> When the Forward Emergency Braking system is turned ON or OFF, the Predictive Forward Collision Warning system is turned ON or OFF simultaneously.

A  
B  
C  
D  
E  
F  
G  
H  
I  
J  
K  
L  
M  
N  
P

DAS

## HANDLING PRECAUTION

### Precautions for Predictive Forward Collision Warning

INFOID:000000011953144

- The Predictive Forward Collision Warning system is designed to warn the driver before a collision, but will not avoid a collision. It is the driver's responsibility to stay alert, drive safely and be in control of the vehicle at all times.
- The radar sensor does not detect the following objects:
  - Pedestrians, animals, or obstacles in the roadway.
  - Oncoming vehicles.
  - Crossing vehicles.
- The Predictive Forward Collision Warning system does not function when a vehicle ahead is a narrow vehicle, such as a motorcycle.
- The radar sensor may not detect a second vehicle ahead in the following conditions:
  - Snow or heavy rain.
  - Dirt, ice, snow or other material covering the radar sensor.
  - Interference by other radar sources.
  - Snow or road spray from traveling vehicles is splashed.
  - Driving in a tunnel.
- The radar sensor may not detect a second vehicle when the vehicle ahead is being towed.
- When the distance to the vehicle ahead is too close, the beam of the radar sensor is obstructed.
- The radar sensor may not detect a second vehicle when driving on a steep downhill slope or on roads with sharp curves.
- Excessive noise will interfere with the warning tone sound, and it may not be heard.

### Precautions for Blind Spot Warning

INFOID:000000011953145

#### SIDE RADAR HANDLING

- Side radar for Blind Spot Warning system is located inside the rear bumper.
- Always keep the rear bumper near the side radar clean.
- Do not attach a sticker (including transparent material), install an accessory or paint near the side radar.
- Do not strike or damage the areas around the side radar.
- Do not strike, damage, and scratch the side radar, especially the vent seal (gray circular) area, under repair.

#### BLIND SPOT WARNING

- The Blind Spot Warning system is not a replacement for proper driving procedure and is not designed to prevent contact with vehicles or objects. When changing lanes, always use the side and rear mirrors and turn and look in the direction the vehicle will move to ensure it is safe to change lanes. Never rely solely on the Blind Spot Warning system.
- The Blind Spot Warning system may not provide the warning for vehicles that pass through the detection zone quickly.
- Excessive noise (for example, audio system volume or open vehicle window) will interfere with the chime sound, and it may not be heard.
- The side radar may not be able to detect and activate Blind Spot Warning when certain objects are present such as:
  - Pedestrians, bicycles, animals.
  - Several types of vehicles such as motorcycles.
  - Oncoming vehicles.
  - Vehicles remaining in the detection zone when driver accelerates from a stop.
  - A vehicle merging into an adjacent lane at a speed approximately the same as vehicle.
  - A vehicle approaching rapidly from behind.
  - A vehicle which own vehicle overtakes rapidly.
- Severe weather or road spray conditions may reduce the ability of the radar to detect other vehicles.
- The side radar detection zone is designed based on a standard lane width. When driving in a wider lane, the side radar may not detect vehicles in an adjacent lane. When driving in a narrow lane, the side radar may detect vehicles driving two lanes away.
- The side radar is designed to ignore most stationary objects: however, objects such as guardrails, walls, foliage and parked vehicles may occasionally be detected. This is a normal operating condition.

# HANDLING PRECAUTION

< SYSTEM DESCRIPTION >

[DRIVER ASSISTANCE SYSTEM]

## Precautions for Rear Cross Traffic Alert

INFOID:0000000011953146

### SIDE RADAR HANDLING

- Side radar for Rear Cross Traffic Alert system is located inside the rear bumper.
- Always keep the rear bumper near the side radar clean.
- Do not attach a sticker (including transparent material), install an accessory or paint near the side radar.
- Do not strike or damage the areas around the side radar.
- Do not strike, damage, and scratch the side radar, especially the vent seal (gray circular) area, under repair.

### REAR CROSS TRAFFIC ALERT

- Always check surroundings and turn to check what is behind you before backing up. The radar sensors detect approaching (moving) vehicles. The radar sensors cannot detect every object such as:
  - Pedestrians, bicycles, motorcycles, animals or child operated toy vehicles.
  - A vehicle that passing at speeds greater than approximately 19 mph (30 km/h).
  - A vehicle that passing at speeds lower than approximately 5 mph (8 km/h).
- The radar sensors may not detect approaching vehicles in certain situations:
  - When the vehicle that is parked next to you obstructs the beam of the radar sensor.
  - When the vehicle is parked in an angled parking space.
  - When the vehicle is parked on an incline.
  - When an approaching vehicle turns into your vehicle's parking lot isle.
  - When the angle formed by your vehicle is too small.
- The following conditions may reduce the ability of the radar to detect other vehicles:
  - Severe weather
  - Road spray
  - Ice build-up on the vehicle
  - Frost on the vehicle
  - Dirt build-up on the vehicle
- Do not attach stickers (including transparent material), install accessories or apply additional paint near the radar sensors. These conditions may reduce the ability of the radar to detect other vehicles.
- Do not use RCTA system when towing a trailer.
- Excessive noise (e.g., audio system volume or open vehicle window) will interfere with the chime sound, and it may not be heard.

A  
B  
C  
D  
E  
F  
G  
H  
I  
J  
K  
L  
M  
N  
P

DAS

# DIAGNOSIS SYSTEM (ADAS CONTROL UNIT)

< SYSTEM DESCRIPTION >

[DRIVER ASSISTANCE SYSTEM]

## DIAGNOSIS SYSTEM (ADAS CONTROL UNIT)

### CONSULT Function (ICC/ADAS)

INFOID:000000011953147

#### APPLICATION ITEMS

CONSULT performs the following functions via CAN communication using ADAS control unit:

Diagnosis mode	Description
Configuration	<ul style="list-style-type: none"><li>The vehicle specification that is written in ADAS control unit can be displayed or stored.</li><li>The vehicle specification can be written when ADAS control unit is replaced.</li></ul>
Work support	Displays causes of automatic system cancellation that occurred during system control.
Self Diagnostic Result	Displays the name of a malfunctioning system stored in the ADAS control unit.
Data Monitor	Displays ADAS control unit input/output data in real time.
Active Test	Enables an operational check of a load by transmitting a driving signal from the ADAS control unit to the load.
ECU Identification	Displays ADAS control unit part number.
CAN Diag Support Monitor	Displays a reception/transmission state of CAN communication and ITS communication.

#### CONFIGURATION

Configuration includes functions as follows:

Function	Description
Read/Write Configuration	Before Replace ECU Allows the reading of vehicle specification written in ADAS control unit to store the specification in CONSULT.
	After Replace ECU Allows the writing of the vehicle information stored in CONSULT into the ADAS control unit.
Manual Configuration	Allows the writing of the vehicle specification into the ADAS control unit by hand.

#### WORK SUPPORT

Work support items	Description
CAUSE OF AUTO-CANCEL 5	Displays causes of automatic system cancellation that occurred during control of the Intelligent Cruise Control (ICC).

#### NOTE:

- Causes of the maximum five cancellations (system cancel) are displayed.
- The displayed cancellation causes display the number of the ignition switch ON/OFF up to 254. It is fixed to 254 if it is over 254. It returns to 0 when the same cancellation cause is detected again.

Display Items for the Cause of Automatic Cancellation 1

Cause of cancellation	Intelligent Cruise Control (ICC)	Description
CAN COMM ERROR	×	ADAS control unit received an abnormal signal with CAN communication.
NO RECORD	×	—

#### SELF DIAGNOSTIC RESULT

Refer to [DAS-25. "DTC Index"](#).

# DIAGNOSIS SYSTEM (ADAS CONTROL UNIT)

[DRIVER ASSISTANCE SYSTEM]

< SYSTEM DESCRIPTION >

**NOTE:**

- The details of time display are as per the following:
- CRNT: A malfunction is detected now.
- PAST: A malfunction was detected in the past.
- ODO/TRIP METER (Mileage) and VOLTAGE (IGN voltage) are displayed on FFD (Freeze Frame Data).

**DATA MONITOR**

**NOTE:**

The following table includes information (items) inapplicable to this vehicle. For information (items) applicable to this vehicle, refer to CONSULT display items.

Monitored item [Unit]	ALL SIG (ICC)	MAIN SIG (ICC)	MAIN SIG (BSW)	Description
MAIN SW [On/Off]	×	×	×	Indicates [ON/OFF] status as judged from ICC steering switch.
SET/COAST SW [On/Off]	×	×		Indicates [ON/OFF] status as judged from ICC steering switch.
CANCEL SW [On/Off]	×	×		Indicates [ON/OFF] status as judged from ICC steering switch.
RESUME/ACC SW [On/Off]	×	×		Indicates [ON/OFF] status as judged from ICC steering switch.
DISTANCE SW [On/Off]	×			Indicates [ON/OFF] status as judged from ICC steering switch.
CRUISE OPE [On/Off]	×	×		Indicates whether controlling or not (ON means "controlling").
BRAKE SW [On/Off]	×	×	×	Indicates [ON/OFF] status as judged from ICC brake switch signal (ECM transmits ICC brake switch signal through CAN communication).
STOP LAMP SW [On/Off]	×	×	×	Indicates [ON/OFF] status as judged from stop lamp switch signal (ECM transmits stop lamp switch signal through CAN communication).
IDLE SW [On/Off]	×			Indicates [ON/OFF] status of idle switch read from ADAS control unit through CAN communication (ECM transmits ON/OFF status through CAN communication).
SET DISTANCE [Short/Mid/Long]	×	×		Indicates set distance memorized in ADAS control unit.
CRUISE LAMP [On/Off]	×	×		Indicates [ON/OFF] status of MAIN switch indicator output.
OWN VHCL [On/Off]	×			<b>NOTE:</b> The item is displayed, but it is not monitored.
VHCL AHEAD [On/Off]	×			Indicates [ON/OFF] status of vehicle ahead detection indicator output.
ICC WARNING [On/Off]	×			Indicates [ON/OFF] status of ICC system warning lamp output.
VHCL SPEED SE [km/h] or [mph]	×	×	×	Indicates vehicle speed calculated from ADAS control unit through CAN communication [ABS actuator and electric unit (control unit) transmits vehicle speed signal (wheel speed) through CAN communication].
SET VHCL SPD [km/h] or [mph]	×	×		Indicates set vehicle speed memorized in ADAS control unit.
BUZZER O/P [On/Off]	×			Indicates [ON/OFF] status of ICC warning chime output.
THRTL SENSOR [deg]	×	×		<b>NOTE:</b> The item is displayed, but it is not monitored.
ENGINE RPM [rpm]	×			Indicates engine speed read from ADAS control unit through CAN communication (ECM transmits engine speed signal through CAN communication).
WIPER SW [OFF/LOW/HIGH]	×			Indicates wiper [OFF/LOW/HIGH] status (BCM transmits front wiper request signal through CAN communication).

DAS

A  
B  
C  
D  
E  
F  
G  
H  
I  
J  
K  
L  
M  
N  
P

# DIAGNOSIS SYSTEM (ADAS CONTROL UNIT)

< SYSTEM DESCRIPTION >

[DRIVER ASSISTANCE SYSTEM]

Monitored item [Unit]	ALL SIG (ICC)	MAIN SIG (ICC)	MAIN SIG (BSW)	Description
YAW RATE [deg/s]	×			<b>NOTE:</b> The item is displayed, but it is not monitored.
BA WARNING [On/Off]	×			Indicates [ON/OFF] status of FEB indicator lamp output.
STP LMP DRIVE [On/Off]	×	×		Indicates [ON/OFF] status of ICC brake hold relay drive output.
D POSITION SW [On/Off]	×			Indicates [ON/OFF] status of "D" or "M" positions read from ADAS control unit through CAN communication; ON when position "D" or "M" (TCM transmits shift selector position signal through CAN communication).
NP RANGE SW [On/Off]	×			Indicates shift selector position signal read from ADAS control unit through CAN communication (TCM transmits shift selector position signal through CAN communication).
PKB SW [On/Off]	×			Parking brake switch status [ON/OFF] judged from the parking brake switch signal that ADAS control unit receives via CAN communication is displayed (combination meter transmits the parking brake switch signal via CAN communication).
PWR SUP MONI [V]	×	×		Indicates ignition voltage input monitored by ADAS control unit.
VHCL SPD AT [km/h] or [mph]	×			Indicates vehicle speed calculated from CVT vehicle speed sensor read from ADAS control unit through CAN communication (TCM transmits CVT vehicle speed sensor signal through CAN communication).
THRTL OPENING [%]	×	×		Indicates throttle position read from ADAS control unit through CAN communication (ECM transmits accelerator pedal position signal through CAN communication).
GEAR [1, 2, 3, 4, 5, 6, 7]	×			Indicates CVT gear position read from ADAS control unit through CAN communication (TCM transmits current gear position signal through CAN communication).
CLUTCH SW SIG [On/Off]	×	×	×	Indicates [ON/OFF] status as judged from clutch pedal position signal (ECM transmits ICC clutch switch signal through CAN communication).
NP SW SIG [On/Off]	×			Indicates [ON/OFF] status as judged from park/neutral position switch signal (ECM transmits park/neutral position switch signal through CAN communication).
MODE SIG [OFF, ICC, ASCD]	×			Indicates the active mode from ICC or ASCD [conventional (fixed speed) cruise control mode].
SET DISP IND [On/Off]	×			Indicates [ON/OFF] status of SET switch indicator output.
DISTANCE [m]	×			Indicates the distance from the vehicle ahead.
RELATIVE SPD [m/s]	×			Indicates the relative speed of the vehicle ahead.
ON ROOT GUIDANCE [On/Off]	×			<b>NOTE:</b> The item is displayed, but it is not monitored.
DYNA ASIST SW [On/Off]	×	×	×	Indicates [ON/OFF] status as judged from ICC steering switch signal (ECM transmits ICC steering switch signal through CAN communication).
IBA SW [On/Off]	×	×		<b>NOTE:</b> The item is displayed, but it is not monitored.
NAVI ICC DISP [On/Off]				<b>NOTE:</b> The item is displayed, but it is not monitored.
Shift position [Off, P, R, N, D, M/T1 - 7]			×	Indicates shift selector position read from ADAS control unit through CAN communication (TCM transmits shift selector position signal through CAN communication).



# DIAGNOSIS SYSTEM (ADAS CONTROL UNIT)

< SYSTEM DESCRIPTION >

[DRIVER ASSISTANCE SYSTEM]

Monitored item [Unit]	ALL SIG (ICC)	MAIN SIG (ICC)	MAIN SIG (BSW)	Description
Turn signal [OFF/LH/RH/LH&RH]			×	Indicates turn signal operation status read from ADAS control unit through CAN communication (BCM transmits turn indicator signal through CAN communication).
SIDE G [G]			×	Indicates lateral G acting on the vehicle. This lateral G is judged from a side G sensor signal read by ADAS control unit via CAN communication. (The ABS actuator and electric unit (control unit) transmits a side G sensor signal via CAN communication).
FUNC ITEM (FCW) [On/Off]	×	×	×	Indicates system which can be set to ON/OFF by selecting "Driver Assistance" ⇒ "Emergency Brake" of the integral switch: Forward Emergency Braking.
FUNC ITEM (BSW) [On/Off]	×	×	×	Indicates system which can be set to ON/OFF by selecting "Driver Assistance" ⇒ "Blind Spot" of the integral switch: Blind Spot Warning.
FUNC ITEM (NV-ICC) [Off]	×	×	×	<b>NOTE:</b> The item is displayed, but it is not monitored.
FCW SELECT [On/Off]	×	×	×	Indicates an ON/OFF state of the PFCW system. The PFCW system can be set to ON/OFF by selecting "Driver Assistance" ⇒ "Emergency Brake" of the integral switch.
BSW SELECT [On/Off]	×	×	×	Indicates an ON/OFF state of the BSW system. The BSW system can be set to ON/OFF by selecting "Driver Assistance" ⇒ "Blind Spot" of the integral switch.
NAVI ICC SELECT [Off]	×	×	×	<b>NOTE:</b> The item is displayed, but it is not monitored.
SYS SELECTABILITY [On/Off]	×	×	×	Indicates the availability of ON/OFF switching for "Driving Aids" items received from the integral switch via CAN communication.
BSW/BSI WARN LMP [On/Off]			×	Indicates [ON/OFF] status of Blind Spot Warning malfunction.
BSW SYSTEM ON [On/Off]			×	Indicates [ON/OFF] status of BSW system.
FCW SYSTEM ON [On/Off]	×	×		Indicates [ON/OFF] status of PFCW system.
BATTERY CIRCUIT OFF [On/Off]	×			<b>NOTE:</b> The item is displayed, but it is not used.
SYSTEM CANCEL MESSAGE [NOREQ/SLIP/VDC OFF]	×	×	×	Indicates [ON/OFF] status of system cancel display output.
BSW ON INDICATOR [On/Off]			×	Indicates [ON/OFF] status of BSW system ON display output.
SIDE RADAR BLOCK COND [On/Off]			×	Indicates [ON/OFF] status of side radar with dirt or foreign materials.
BSW IND BRIGHT- NESS [Nothing/Bright/Normal/ Dark]			×	Indicates status of brightness of Blind Spot Warning indicator.
SL MAIN SW [On/Off]		×		Indicates [ON/OFF] status as judged from steering switch.
FUNC ITEM(FEB) [On/Off]	×			Indicates system which can be set to ON/OFF by selecting "Driver Assistance" ⇒ "Emergency Brake" of the integral switch: Forward Emergency Braking

A  
B  
C  
D  
E  
F  
G  
H  
I  
J  
K  
L  
M  
N  
P

DAS

# DIAGNOSIS SYSTEM (ADAS CONTROL UNIT)

< SYSTEM DESCRIPTION >

[DRIVER ASSISTANCE SYSTEM]

Monitored item [Unit]	ALL SIG (ICC)	MAIN SIG (ICC)	MAIN SIG (BSW)	Description
FEB SELECT [On/Off]	×			Indicates an ON/OFF state of the FEB system. The FEB system can be set to ON/OFF by selecting "Driver Assistance"→"Emergency Brake" of the integral switch.
FEB SW [On/Off]	×			Indicates [ON/OFF] status of FEB system.
SL TARGET VEHICLE SPEED [km/h] or [mph]	×			Indicates set vehicle speed memorized in ADAS control unit.
SL SET LAMP [On/Off]	×			Indicates [ON/OFF] status of speed limiter SET display output.
SL LIMIT LAMP [On/Off]	×			Indicates [ON/OFF] status of speed limiter MAIN switch display output.
ASCD CANCEL (LOW SPEED) [NON/CUT]	×			Indicates the vehicle cruise condition. <ul style="list-style-type: none"> <li>• NON: Vehicle speed is maintained at the ASCD set speed.</li> <li>• CUT: Vehicle speed decreased to excessively low, and ASCD operation is cut off.</li> </ul>
ASCD CANCEL (SPEED DIFF) [NON/CUT]	×			Indicates the vehicle cruise condition. <ul style="list-style-type: none"> <li>• NON: Vehicle speed is maintained at the ASCD set speed.</li> <li>• CUT: Vehicle speed decreased to excessively low compared with the ASCD set speed, and ASCD operation is cut off.</li> </ul>
KICK DOWN [On/Off]	×			Displays Kick down state. <ul style="list-style-type: none"> <li>• On: Accelerator pedal is depressed.</li> <li>• Off: Accelerator pedal is fully released.</li> </ul>

## ACTIVE TEST

### CAUTION:

- **Never perform "Active Test" while driving the vehicle.**
- **The "Active Test" cannot be performed when the following systems malfunction is displayed.**
- **ICC system**
- **Blind Spot Warning/RCTA**
- **PFCW/FEB**
- **The "Active Test" cannot be performed when the FEB warning lamp is illuminated.**
- **The "Active Test" cannot be performed when the ICC System is ON.**

Test item	Description
METER LAMP	The FEB warning lamp can be illuminated by ON/OFF operation as necessary.
STOP LAMP	The ICC brake hold relay can be operated by ON/OFF operation as necessary, and the stop lamp can be illuminated.
METER BUZZER	Sounds a buzzer used for BSW, RCTA, ICC, PFCW and FEB by arbitrarily operating ON/OFF.
BRAKE ACTUATOR 1	Activates the brake by an arbitrary operation.
BRAKE ACTUATOR 2	
BRAKE ACTUATOR 3	

## METER LAMP

### NOTE:

The test can be performed only when the engine is running.

Test item	Operation	Description	FEB warning lamp
METER LAMP	Off	Stops sending the FEB warning lamp signal to exit from the test.	OFF
	On	Transmits the FEB warning lamp signal to the combination meter via CAN communication.	ON

## STOP LAMP

# DIAGNOSIS SYSTEM (ADAS CONTROL UNIT)

< SYSTEM DESCRIPTION >

[DRIVER ASSISTANCE SYSTEM]

Test item	Operation	Description	Stop lamp
STOP LAMP	Off	Stops transmitting the ICC brake hold relay drive signal to end the test.	OFF
	On	Transmits the ICC brake hold relay drive signal.	ON

## METER BUZZER

Test item	Operation	Description	Operation sound
METER BUZZER	Off	Stops buzzer output to the combination meter via CAN communication.	—
	On	Starts buzzer output to the combination meter via CAN communication.	—

## BRAKE ACTUATOR

**NOTE:**

The test can be performed only when the engine is running.

Test item	Operation	Description	"PRESS ORDER" value
BRAKE ACTUATOR 1	Off	Stops transmitting the brake fluid pressure control signal to end the test.	—
	On	Starts transmitting the brake fluid pressure control signal to start the test.	10 bar
BRAKE ACTUATOR 2	Off	Stops transmitting the brake fluid pressure control signal to end the test.	—
	On	Starts transmitting the brake fluid pressure control signal to start the test.	20 bar
BRAKE ACTUATOR 3	Off	Stops transmitting the brake fluid pressure control signal to end the test.	—
	On	Starts transmitting the brake fluid pressure control signal to start the test.	30 bar

**NOTE:**

The test is finished 10 seconds after starting.

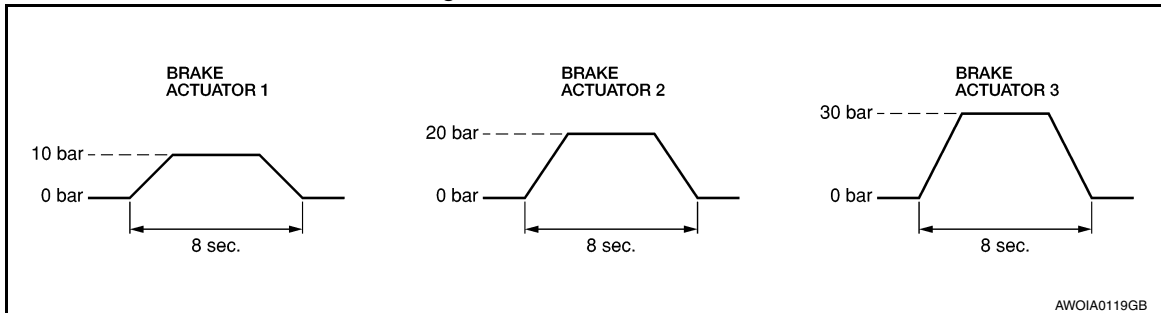

## ECU IDENTIFICATION

Displays ADAS control unit part number.

DAS

# DIAGNOSIS SYSTEM (ICC SENSOR)

[DRIVER ASSISTANCE SYSTEM]

< SYSTEM DESCRIPTION >

## DIAGNOSIS SYSTEM (ICC SENSOR)

### CONSULT Function (LASER/RADAR)

INFOID:000000012386692

#### APPLICATION ITEMS

CONSULT performs the following functions via CAN communication with ADAS control unit and the communication with ICC sensor.

Diagnosis mode	Description
Self Diagnostic Result	Displays malfunctioning system memorized in ICC sensor
Data Monitor	Displays real-time input/output data of ICC sensor
Work support	It can monitor the adjustment direction indication in order to perform the radar adjustment operation smoothly
ECU Identification	Displays ICC sensor part number
CAN Diag Support Monitor	The results of transmit/receive diagnosis of ITS communication can be read.

#### SELF DIAGNOSTIC RESULT

Refer to [DAS-123, "DTC Index"](#).

#### DATA MONITOR

Monitored item [Unit]	Description
VHCL SPEED SE [km/h] or [mph]	Vehicle speed judged from a vehicle speed signal read by the ICC sensor via ITS communication is displayed [ADAS control unit receives a vehicle speed signal from ABS actuator and electric unit (control unit) via CAN communication and transmits the calculated vehicle speed to ICC sensor via ITS communication].
YAW RATE [deg/s]	Indicates yaw rate read from ADAS control unit through ITS communication [ADAS control unit receives yaw rate signal from ABS actuator and electric unit (control unit) via CAN communication and transmits yaw rate calculated by the ADAS control unit] Yaw rate judged from a yaw rate signal read by ICC sensor via ITS communication is displayed [ADAS control unit receives a yaw rate signal from ABS actuator and electric unit (control unit) via CAN communication and transmits the calculated yaw rate to ICC sensor via ITS communication].
PWR SUP MONI [V]	Indicates IGN voltage input by ICC sensor
DISTANCE [m]	Indicates the distance from the vehicle ahead
RELATIVE SPD [m/s]	Indicates the relative speed of the vehicle ahead
LASER OFFSET [m]	<b>NOTE:</b> The item is indicated but not used.
LASER HEIGHT [m]	<b>NOTE:</b> The item is indicated but not used.
STEERING ANGLE [deg]	The steering angle is displayed.
STRG ANGLE SPEED [deg/s]	The steering angle speed is displayed.
L/R ADJUST [deg]	Indicates a horizontal correction value of the radar
U/D ADJUST [deg]	Indicates a vertical correction value of the radar
FCW SYSTEM ON	<b>NOTE:</b> The item is indicated, but not used.
FCW SELECT	<b>NOTE:</b> The item is indicated, but not used.

# DIAGNOSIS SYSTEM (ICC SENSOR)

## [DRIVER ASSISTANCE SYSTEM]

### < SYSTEM DESCRIPTION >

Monitored item [Unit]	Description	
PFCW SELECT	NOTE: The item is indicated, but not used.	A
PFCW SYSTEM ON	NOTE: The item is indicated, but not used.	B
FEB SW	NOTE: The item is indicated, but not used.	C
FEB SELECT	Indicates [ON/OFF] state of the PFCW system.	
MAIN SW	Indicates [ON/OFF] status as judged from ICC steering switch.	D
ICC/ASCD MODE	NOTE: The item is indicated, but not used.	E
SET/COAST SW	Indicates [ON/OFF] status as judged from ICC steering switch.	E
CANCEL SW	Indicates [ON/OFF] status as judged from ICC steering switch.	
RESUME/ACC SW	Indicates [ON/OFF] status as judged from ICC steering switch.	
DISTANCE SW	Indicates [ON/OFF] status as judged from ICC steering switch.	F
BRAKE SW	Indicates [ON/OFF] status as judged from brake pedal position switch signal [ECM transmits brake pedal position switch signal through CAN communication].	
STOP LAMP SW	Indicates [ON/OFF] status as judged from stop lamp switch signal [ABS actuator and electric unit (control unit) transmits stop lamp switch signal through CAN communication].	G
IDLE SW	Indicates [ON/OFF] status of idle switch read from ICC sensor through CAN communication (ECM transmits ON/OFF status through CAN communication).	H
CRUISE LAMP	Indicates [ON/OFF] status of MAIN switch indicator output.	
OWN VHCL	NOTE: The item is indicated, but not used.	I
VHCL AHEAD	Indicates [ON/OFF] status of vehicle ahead detection indicator output.	
SET DISTANCE	Indicates set distance memorized in ADAS control unit.	J
SET VHCL SPD [km/h] or [mph]	NOTE: The item is indicated, but not used.	
THRTL SENSOR [%]	Indicates throttle position read from ISS sensor through CAN communication (ECM transmits accelerator pedal position signal through CAN communication).	K
VEHICLE AHEAD DETECT	Indicates [ON/OFF] status of vehicle ahead detection indicator output.	
STATIC OBSTACLE DETECT	Indicates [ON/OFF] status of static obstacle detection.	L
BUZZER O/P	[ON/OFF] Indicates [On/Off] status of warning chime output.	
FUNC ITEM (FCW)	NOTE: The item is indicated, but not used.	M
FUNC ITEM (PFCW)	Indicates systems status	
FUNC ITEM (FEB)	Indicates systems status	N
FUNC ITEM (ICC)	Indicates systems status	
PRESS_ORDER [bar]	Indicates status as judged from brake fluid pressure signal [ABS actuator and electric unit (control unit) transmits brake fluid pressure signal through CAN communication].	DAS
D RANGE SW	Indicates [ON/OFF] status as judged from D position switch signal (TCM transmits shift position signal through CAN communication).	
NP RANGE SW	Indicates [ON/OFF] status as judged from N/P position switch signal (TCM transmits shift position signal through CAN communication).	P
PKB SW	Parking brake switch status [ON/OFF] judges from the parking brake switch signal that ADAS control unit readout via CAN communication is displayed (combination meter transmits the parking brake switch signal via CAN communication)	
VHCL SPD AT	NOTE: The item is indicated, but not used.	

# DIAGNOSIS SYSTEM (ICC SENSOR)

[DRIVER ASSISTANCE SYSTEM]

## < SYSTEM DESCRIPTION >

Monitored item [Unit]	Description
Shift position	Indicates shift position read from ADAS control unit through CAN communication (TCM transmits shift position signal through CAN communication).
Turn signal	NOTE: The item is indicated, but not used.
SYSTEM CANCEL MESSAGE	Indicates [ON/OFF] status of system cancel display output.
DISP VHCL SPD [km/h] or [mph]	NOTE: The item is indicated, but not used.
VHCL SPD UNIT	Indicates vehicle speed unit read from ICC sensor through CAN communication (combination meter transmits vehicle speed unit through CAN communications).
ADAS AVAILABLE COND	NOTE: The item is indicated, but not used.
ICC SET STATUS	NOTE: The item is indicated, but not used.
ICC MALF	NOTE: The item is indicated, but not used.
ADAS MALF	Indicates [ON/OFF] status of ADAS malfunction.
STOP LAMP RELAY ON	Indicates [ON/OFF] status of stop lamp relay fixed on.
STOP LAMP RELAY OFF	Indicates [ON/OFF] status of stop lamp relay fixed off.
ACCEL COM VALUE 1 [m/s <sup>2</sup> ]	Indicates accel command calculated from set speed and information of ahead vehicle.
ICC STATUS	Indicates ICC status.
ACCEL COM VALUE 2	NOTE: The item is indicated, but not used.
MILEAGE	NOTE: The item is indicated, but not used.

## WORK SUPPORT

Work support items	Description
MILLIWAVE RADAR ADJUST	Outputs millimeter waves, calculates the displacement in radar direction, and indicates an adjustment direction
CAUSE OF AUTO-CANCEL	Displays causes of automatic cancellation occurred during Intelligent Cruise Control system.

ICC sensor Adjust

Refer to [CCS-59. "Description"](#).

## ECU IDENTIFICATION

ICC sensor part number is displayed.

## CAUSE OF AUTO CANCEL

Work support items	Description
OPERATING ABS	ABS function was operated.
OPERATING TCS	TCS function was operated.
OPERATING VDC	VDC function was operated.
ECM CIRCUIT	ECM did not permit ICC operation.
OP SW VOLT CIRC	The ICC steering switch input voltage is not within standard range.
OP SW DOUBLE TOUCH	The ICC steering switches were pressed at the same time.
VHCL SPD DOWN	Vehicle speed is lower than 24 km/h (15 mph).
WHL SPD ELEC NOISE	Wheel speed sensor signal caught electromagnetic noise.
VDC/TCS OFF SW	VDC OFF switch was pressed.

## DIAGNOSIS SYSTEM (ICC SENSOR)

[DRIVER ASSISTANCE SYSTEM]

< SYSTEM DESCRIPTION >

Work support items	Description
VHCL SPD UNMATCH	Wheel speed became different from A/T vehicle speed.
TIRE SLIP	Wheel slipped.
IGN LOW VOLT	Decrease in ICC sensor ignition voltage.
PARKING BRAKE ON	The parking brake is operating.
WHEEL SPD UNMATCH	The wheel speed of all four wheels are out of the specified values.
INCHING LOST	a vehicle ahead is not detected during the following driving when the vehicle speed is approximately 24 km/h (15mph) or less.
CAN COMM ERROR	ICC sensor received an abnormal signal with CAN communication.
ABS/TCS/VDC CIRC	An abnormal condition occurs in VDC/TCS/ABS system.
ECD CIRCUIT	An abnormal condition occurs in ECD system.
ASCD VHCL SPD DTAC	Vehicle speed is detached from the set vehicle speed.
ASCD DOUBLE COMD	Cancel switch and operation switch are detected simultaneously.
FEB OPERATED	FEB activated.
VHL AHAD LOST (CLSE RANGE)	A vehicle ahead lost close range.
NO RECORD	—

A  
B  
C  
D  
E  
F  
G  
H  
I  
J  
K  
L  
M  
N  
P

DAS

# DIAGNOSIS SYSTEM (SIDE RADAR LH)

< SYSTEM DESCRIPTION >

[DRIVER ASSISTANCE SYSTEM]

## DIAGNOSIS SYSTEM (SIDE RADAR LH)

### CONSULT Function (SIDE RADAR LEFT)

INFOID:000000011953149

#### DESCRIPTION

CONSULT performs the following functions by communicating with the side radar LH.

Diagnosis mode	Function
Self Diagnostic Result	Displays memorized DTC in the side radar.
Data Monitor	Displays real-time data of side radar.
Active Test	Enables operation check of electrical loads by sending driving signal to them.
ECU Identification	Displays part number of side radar.

#### SELF DIAGNOSTIC RESULT

##### Self Diagnostic Result

Displays memorized DTC in side radar LH. Refer to [DAS-127. "DTC Index"](#).

##### FFD (Freeze Frame Data)

The side radar records the following data when the malfunction is detected.

Freeze Frame Data item	Description
VHCL SP from ADAS	The vehicle speed (from ADAS control unit) at the moment a malfunction is detected is displayed.
TURN SIG STATUS	Turn signal status at the moment a malfunction is detected is displayed.

#### DATA MONITOR

##### NOTE:

The following table includes information (items) inapplicable to this vehicle. For information (items) applicable to this vehicle, refer to CONSULT display items.

Monitored item [Unit]	Description
BSW/CTA WARN STATUS [On/Off]	Indicates [ON/OFF] status of vehicle detection
CTA SYSTEM ON [On/Off]	Indicates [ON/OFF] status of Rear Cross Traffic Alert system
BSW STATUS [On/Off]	Indicates [ON/OFF] status of Blind Spot Warning system
VHCL SPD SE [km/h]	Indicates vehicle speed [km/h]
TURN SIGNAL [LH/RH/Off]	Indicates the [LH/RH/OFF] operation of the signal
SHIFT POSITION [P/R/N/D]	Indicates position of transmission range switch
LUMINANCE (LEFT) [Hi/Lo]	Indicates the left side luminance level of the radar
LUMINANCE (RIGHT) [Hi/Lo]	Indicates the right side luminance level of the radar

#### ACTIVE TEST

##### CAUTION:

- Never perform the active test while driving.
- Active test cannot be started while the BSW indicator is illuminated.



# DIAGNOSIS SYSTEM (SIDE RADAR LH)

[DRIVER ASSISTANCE SYSTEM]

< SYSTEM DESCRIPTION >

Active test item	Operation	Description
BSW/BSI INDICATOR DRIVE	On	Outputs the voltage to illuminate the BSW/RCTA indicator
	Off	Stops the voltage to illuminate the BSW/RCTA indicator

A

B

C

D

E

F

G

H

I

J

K

L

M

N

DAS

P

# DIAGNOSIS SYSTEM (SIDE RADAR RH)

< SYSTEM DESCRIPTION >

[DRIVER ASSISTANCE SYSTEM]

## DIAGNOSIS SYSTEM (SIDE RADAR RH)

### CONSULT Function (SIDE RADAR RIGHT)

INFOID:000000011953150

#### DESCRIPTION

CONSULT performs the following functions by communicating with the side radar RH.

Diagnosis mode	Function
Self Diagnostic Result	Displays memorized DTC in the side radar.
Data Monitor	Displays real-time data of side radar.
Active Test	Enables operation check of electrical loads by sending driving signal to them.
ECU Identification	Displays part number of side radar.

#### SELF DIAGNOSTIC RESULT

##### Self Diagnostic Result

Displays memorized DTC in side radar RH. Refer to [DAS-129. "DTC Index"](#).

##### FFD (Freeze Frame Data)

The side radar records the following data when the malfunction is detected.

Freeze Frame Data item	Description
VHCL SP from ADAS	The vehicle speed (from ADAS control unit) at the moment a malfunction is detected is displayed.
TURN SIG STATUS	Turn signal status at the moment a malfunction is detected is displayed.

#### DATA MONITOR

##### NOTE:

The following table includes information (items) inapplicable to this vehicle. For information (items) applicable to this vehicle, refer to CONSULT display items.

Monitored item [Unit]	Description
BSW/CTA WARN STATUS [On/Off]	Indicates [On/Off] status of vehicle detection
CTA SYSTEM ON [On/Off]	Indicates [On/Off] status of Rear Cross Traffic Alert system
BSW STATUS [On/Off]	Indicates [On/Off] status of Blind Spot Warning system
VHCL SPD SE [km/h]	Indicates vehicle speed [km/h]
TURN SIGNAL [LH/RH/Off]	Indicates the [LH/RH/OFF] operation of the turn signal
SHIFT POSITION [P/R/N/D]	Indicates position of transmission range switch
LUMINANCE (LEFT) [Hi/Lo]	Indicates the left side luminance level of the radar
LUMINANCE (RIGHT) [Hi/Lo]	Indicates the right side luminance level of the radar

#### ACTIVE TEST

##### CAUTION:

- Never perform the active test while driving.
- Active test cannot be started while the BSW indicator is illuminated.

# DIAGNOSIS SYSTEM (SIDE RADAR RH)

< SYSTEM DESCRIPTION >

[DRIVER ASSISTANCE SYSTEM]

Active test item	Operation	Description
BSW/BSI INDICATOR DRIVE	On	Outputs the voltage to illuminate the BSW indicator
	Off	Stops the voltage to illuminate the BSW indicator

A

B

C

D

E

F

G

H

I

J

K

L

M

N

DAS

P

# ADAS CONTROL UNIT

< ECU DIAGNOSIS INFORMATION >

[DRIVER ASSISTANCE SYSTEM]

## ECU DIAGNOSIS INFORMATION

### ADAS CONTROL UNIT

#### Reference Value

INFOID:0000000011953151

#### VALUES ON THE DIAGNOSIS TOOL

**NOTE:**

The following table includes information (items) inapplicable to this vehicle. For information (items) applicable to this vehicle, refer to CONSULT display items.

Monitor item	Condition		Value/Status
MAIN SW	Ignition switch ON	When MAIN (ON/OFF) switch is pressed.	On
		When MAIN (ON/OFF) switch is not pressed.	Off
SET/COAST SW	Ignition switch ON	When SET/COAST switch is pressed.	On
		When SET/COAST switch is not pressed.	Off
CANCEL SW	Ignition switch ON	When CANCEL switch is pressed.	On
		When CANCEL switch is not pressed.	Off
RESUME/ACC SW	Ignition switch ON	When RESUME/ACCELERATE switch is pressed.	On
		When RESUME/ACCELERATE switch is not pressed.	Off
DISTANCE SW	Ignition switch ON	When DISTANCE switch is pressed.	On
		When DISTANCE switch is not pressed.	Off
CRUISE OPE	Drive the vehicle and activate the ICC system	When ICC system is controlling.	On
		When ICC system is not controlling.	Off
BRAKE SW	Ignition switch ON	When brake or clutch pedal is depressed.	Off
		When brake or clutch pedal is not depressed.	On
STOP LAMP SW	Ignition switch ON	When brake pedal is depressed.	On
		When brake pedal is not depressed.	Off
IDLE SW	Engine running	Idling	On
		Except idling (depress accelerator pedal)	Off
SET DISTANCE	<ul style="list-style-type: none"> <li>• Start the engine and turn the ICC system ON</li> <li>• Press the DISTANCE switch to change the ICC system</li> </ul>	When set to "long"	Long
		When set to "middle"	Mid
		When set to "short"	Short
CRUISE LAMP	Start the engine and press MAIN switch	ICC system ON (MAIN switch indicator ON).	On
		ICC system OFF (MAIN switch indicator OFF).	Off
OWN VHCL	<b>NOTE:</b> The item is indicated, but not monitored		Off
VHCL AHEAD	Drive the vehicle and activate the ICC system	When a vehicle ahead is detected (vehicle ahead detection indicator ON).	On
		When a vehicle ahead is not detected (vehicle ahead detection indicator OFF).	Off
ICC WARNING	Start the engine and press MAIN switch	When ICC system is malfunctioning (ICC system malfunction ON).	On
		When ICC system is normal (ICC system malfunction OFF).	Off

# ADAS CONTROL UNIT

< ECU DIAGNOSIS INFORMATION >

[DRIVER ASSISTANCE SYSTEM]

Monitor item	Condition		Value/Status
VHCL SPEED SE	While driving		Displays the vehicle speed calculated by ADAS control unit
SET VHCL SPD	While driving	When vehicle speed is set.	Displays the set vehicle speed
BUZZER O/P	Engine running	When the buzzer of the following system operates: • ICC system • PFCW system • FEB system	On
		When the buzzer of the following system does not operate: • ICC system • PFCW system • FEB system	Off
THRTL SENSOR	<b>NOTE:</b> The item is indicated, but not monitored.		0.0
ENGINE RPM	Engine running		Equivalent to tachometer reading
WIPER SW	Ignition switch ON	Wiper not operating.	Off
		Wiper LO operation.	Low
		Wiper HI operation.	High
YAW RATE	<b>NOTE:</b> The item is indicated, but not monitored.		0.0
BA WARNING	Engine running	FEB OFF indicator lamp ON. • When FEB system is malfunctioning. • When FEB system is turned to OFF.	On
		FEB OFF indicator lamp OFF. • When FEB system is normal. • When FEB system is turned to ON.	Off
STP LMP DRIVE	Drive the vehicle and activate the ICC system	When ICC brake hold relay is activated.	On
		When ICC brake hold relay is not activated.	Off
D POSITION SW	Engine running	When the shift selector is in "D" position or manual mode.	On
		When the shift selector is in any position other than "D" or manual mode.	Off
NP RANGE SW	Engine running	When the shift selector is in "N" or "P" position.	On
		When the shift selector is in any position other than "N" or "P".	Off
PKB SW	Ignition switch ON	When the parking brake is applied.	On
		When the parking brake is released.	Off
PWR SUP MONI	Engine running		Power supply voltage value of ADAS control unit
VHCL SPD AT	While driving		Value of CVT vehicle speed sensor signal
THRTL OPENING	Engine running	Depress accelerator pedal.	Displays the throttle position
GEAR	While driving		Displays the gear position

A  
B  
C  
D  
E  
F  
G  
H  
I  
J  
K  
L  
M  
N  
P

DAS

# ADAS CONTROL UNIT

< ECU DIAGNOSIS INFORMATION >

[DRIVER ASSISTANCE SYSTEM]

Monitor item	Condition		Value/Status
CLUTCH SW SIG	Ignition switch ON	When clutch or brake pedal is depressed.	On
		When clutch or brake pedal is not depressed.	Off
NP SW SIG	Ignition switch ON	When the shift selector is in neutral position.	On
		When the shift selector is in any position other than neutral.	Off
MODE SIG	Start the engine and press MAIN switch	When ICC system is deactivated.	Off
		When ICC system is activated.	ICC
SET DISP IND	Press SET/COAST switch	SET switch indicator ON.	On
		SET switch indicator OFF.	Off
DISTANCE	Drive the vehicle and activate the ICC system	When a vehicle ahead is detected.	Displays the distance from the preceding vehicle
		When a vehicle ahead is not detected.	0.0
RELATIVE SPD	Drive the vehicle and activate the ICC system	When a vehicle ahead is detected.	Displays the relative speed.
		When a vehicle ahead is not detected.	0.0
ON ROOT GUIDE	<b>NOTE:</b> The item is indicated, but not monitored.		Off
FCW SYSTEM ON	Ignition switch ON	When the PFCW system is ON.	On
		When the PFCW system is OFF.	Off
Shift position	<ul style="list-style-type: none"> <li>• Engine running</li> <li>• While driving</li> </ul>		Displays the shift selector position
Turn signal	Turn signal lamps OFF.		Off
	Turn signal lamp LH blinking.		LH
	Turn signal lamp RH blinking.		RH
	Turn signal lamp LH and RH blinking.		LH&RH
SIDE G	While driving	Vehicle turning right.	Negative value
		Vehicle turning left.	Positive value
FUNC ITEM	Ignition switch ON		FUNC3
FUNC ITEM (FCW)	Engine running		On
FUNC ITEM (BSW)	Engine running		On
FUNC ITEM (NV-ICC)	<b>NOTE:</b> The item is indicated, but not monitored		Off
FCW SELECT	Ignition switch ON	"Forward Emergency Braking" set when the integral switch is ON.	On
		"Forward Emergency Braking" set when the integral switch is OFF.	Off
BSW SELECT	Ignition switch ON	"Blind Spot Warning" set when the integral switch is ON.	On
		"Blind Spot Warning" set when the integral switch is OFF.	Off
NAVI ICC SELECT	<b>NOTE:</b> The item is indicated, but not monitored.		Off
SYS SELECTABILITY	Ignition switch ON	Items set with the integral switch can be switched normally.	On
		Items set with the integral switch cannot be switched normally.	Off

# ADAS CONTROL UNIT

< ECU DIAGNOSIS INFORMATION >

[DRIVER ASSISTANCE SYSTEM]

Monitor item	Condition		Value/Status
BSW WARN LMP	Engine running	When the BSW system is malfunctioning.	On
		When the BSW system is normal.	Off
BSW SYSTEM ON	Ignition switch ON	When the BSW system is ON.	On
		When the BSW system is OFF.	Off
FCW SYSTEM ON	Engine running	When the FEB/PFCW system is ON.	On
		When the FEB/PFCW system is OFF.	Off
BATTERY CIRCUIT OFF	<b>NOTE:</b> The item is indicated, but not used.		Off
SYSTEM CANCEL MESSAGE	Engine running	System cancel display ON.	On
		System cancel display OFF.	Off
BSW ON INDICATOR	Engine running	BSW system display ON.	On
		BSW system display OFF.	Off
SIDE RADAR BLOCK COND	Engine running	Front bumper or side radar is dirty.	On
		Front bumper and side radar are clean.	Off
BSW IND BRIGHTNESS	Ignition switch ON	BSW system OFF.	Nothing
		Blind Spot Warning indicator brightness bright.	Bright
		Blind Spot Warning indicator brightness normal.	Normal
		Blind Spot Warning indicator brightness dark.	Dark
SL MAIN SW	Engine running	When speed limiter MAIN switch is pressed.	On
		When speed limiter MAIN switch is not pressed.	Off
FUNC ITEM (FEB)	Engine running		On
FEB SELECT	Ignition switch ON	"Forward Emergency Braking" set when the integral switch is ON.	On
		"Forward Emergency Braking" set when the integral switch is OFF.	Off
FEB SW	Engine running	FEB system ON.	On
		FEB system OFF.	Off
SL TARGET VEHICLE SPEED	While driving	When vehicle speed is set.	Displays the set vehicle speed
SL SET LAMP	<ul style="list-style-type: none"> <li>• Drive the vehicle and activate the speed limiter</li> <li>• Press speed limiter MAIN switch</li> </ul>	Speed limiter SET indicator ON.	On
		Speed limiter SET indicator OFF.	Off
SL LIMIT LAMP	<ul style="list-style-type: none"> <li>• Drive the vehicle and activate the speed limiter</li> <li>• Press speed limiter MAIN switch</li> </ul>	Speed limiter system ON.	On
		Speed limiter system OFF.	Off
ASCDCANCEL (LOW SPEED)	Drive the vehicle and activate the ASCD	ASCDCancelled by low vehicle speed.	On
		Other than above.	Off
ASCDCANCEL (SPEED DIFF)	Drive the vehicle and activate the ASCD	ASCDCancelled by difference between set speed and vehicle speed.	On
		Other than above.	Off
KICK DOWN	Drive the vehicle and activate the speed limiter	When accelerator pedal is fully depressed.	On
		Other than above.	Off

A  
B  
C  
D  
E  
F  
G  
H  
I  
J  
K  
L  
M  
N  
P

DAS

# ADAS CONTROL UNIT

< ECU DIAGNOSIS INFORMATION >

[DRIVER ASSISTANCE SYSTEM]

TERMINAL LAYOUT

PHYSICAL VALUES

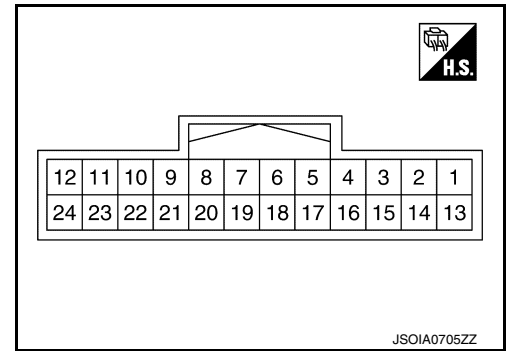

Terminal No. (Wire color)		Description		Condition		Value (Approx.)
+	-	Signal name	Input/ Output			
1 (B)	Ground	Ground	Input	—		0 V
2 (L)		ITS communication high	—	—		—
3 (BG)		Ignition power supply	Input	Ignition switch ON		Battery voltage
5 (Y)		ITS communication low	—	—		—
9 (L)		CAN high	—	—		—
10 (P)		CAN low	—	—		—
14 (W)		ICC brake hold relay drive signal	Output	Ignition switch ON	—	

## Fail-safe (ADAS Control Unit)

INFOID:0000000011953152

If a malfunction occurs in each system, ADAS control unit cancels each control, sounds a beep, and turns ON the warning or indicator lamp.

System	Buzzer	Warning lamp/Warning display	Description
Intelligent Cruise Control (ICC)	High-pitched tone	ICC system warning	Cancel
Forward Emergency Braking (FEB)	High-pitched tone	FEB warning lamp (Yellow)	Cancel
Predictive Forward Collision Warning (PFCW)	High-pitched tone	FEB warning lamp (Yellow)	Cancel
Blind Spot Warning (BSW)	Low-pitched tone	BSW system warning	Cancel
Rear Cross Traffic Alert (RCTA)	—	BSW system warning	Cancel

## DTC Inspection Priority Chart

INFOID:0000000011953153

If multiple DTCs are detected simultaneously, check them one by one depending on the following DTC inspection priority chart.



# ADAS CONTROL UNIT

< ECU DIAGNOSIS INFORMATION >

[DRIVER ASSISTANCE SYSTEM]

Priority	Detected items (DTC)	
1	<ul style="list-style-type: none"> <li>• U1507: LOST COMM (SIDE RDR R)</li> <li>• U1508: LOST COMM (SIDE RDR L)</li> </ul>	A
2	<ul style="list-style-type: none"> <li>• U1000: CAN COMM CIRCUIT</li> <li>• U1321: CONFIGURATION</li> </ul>	B
3	<ul style="list-style-type: none"> <li>• C1A17: ICC SENSOR MALF</li> <li>• C1B53: SIDE RDR R MALF</li> <li>• C1B54: SIDE RDR L MALF</li> </ul>	C
4	<ul style="list-style-type: none"> <li>• C1A01: POWER SUPPLY CIR</li> <li>• C1A02: POWER SUPPLY CIR 2</li> <li>• C1A13: STOP LAMP RLY FIX</li> <li>• C1A14: ECM CIRCUIT</li> <li>• C1A34: COMMAND ERROR</li> <li>• U0121: VDC CAN CIR 2</li> <li>• U0235: ICC SENSOR CAN CIRC 1</li> <li>• U0401: ECM CAN CIR 1</li> <li>• U0402: TCM CAN CIR 1</li> <li>• U0415: VDC CAN CIR 1</li> <li>• U0433: ICC SENSOR CAN CIRC 2</li> <li>• U1503: SIDE RDR L CAN CIR 2</li> <li>• U1504: SIDE RDR L CAN CIR 1</li> <li>• U1505: SIDE RDR R CAN CIR 2</li> <li>• U1506: SIDE RDR R CAN CIR 1</li> </ul>	D E F G
5	<ul style="list-style-type: none"> <li>• C1A03: VHCL SPEED SE CIRC</li> </ul>	H
6	<ul style="list-style-type: none"> <li>• C1A00: CONTROL UNIT</li> </ul>	I

## DTC Index

INFOID:000000011953154

### Systems for fail-safe

- A: Intelligent Cruise Control (ICC)
- B: Forward Emergency Braking (FEB)
- C: Predictive Forward Collision Warning (PFCW)
- D: Blind Spot Warning (BSW)
- E: Rear Cross Traffic Alert (RCTA)

DTC	CONSULT display	Fail-safe System	Reference
NO DTC IS DETECTED. FURTHER TESTING MAY BE REQUIRED	NO DTC IS DETECTED. FURTHER TESTING MAY BE REQUIRED	—	—
U1507	LOST COMM (SIDE RDR R)	D, E	<a href="#">DAS-76</a>
U1508	LOST COMM (SIDE RDR L)	D, E	<a href="#">DAS-77</a>
U1000 <sup>NOTE</sup>	CAN COMM CIRCUIT	A, B, C, D, E	<a href="#">DAS-65</a>
U1321	CONFIGURATION	A, B, C, D, E	<a href="#">DAS-67</a>
C1A17	ICC SENSOR MALF	A, B, C	<a href="#">DAS-51</a>
C1B53	SIDE RDR R MALF	D, E	<a href="#">DAS-53</a>
C1B54	SIDE RDR L MALF	D, E	<a href="#">DAS-54</a>
C1A01	POWER SUPPLY CIR	A, B, C, D, E	<a href="#">DAS-40</a>
C1A02	POWER SUPPLY CIR 2	A, B, C, D, E	<a href="#">DAS-40</a>
C1A13	STOP LAMP RLY FIX	A, B, C	<a href="#">DAS-43</a>
C1A14	ECM CIRCUIT	A, B, C	<a href="#">DAS-49</a>
C1A34	COMMAND ERROR	A, B, C	<a href="#">DAS-52</a>
U0121	VDC CAN CIR 2	A, B, C, D, E	<a href="#">DAS-55</a>

# ADAS CONTROL UNIT

< ECU DIAGNOSIS INFORMATION >

[DRIVER ASSISTANCE SYSTEM]

Systems for fail-safe

- A: Intelligent Cruise Control (ICC)
- B: Forward Emergency Braking (FEB)
- C: Predictive Forward Collision Warning (PFCW)
- D: Blind Spot Warning (BSW)
- E: Rear Cross Traffic Alert (RCTA)

DTC	CONSULT display	Fail-safe System	Reference
U0235	ICC SENSOR CAN CIRC 1	A, C, D, E	<a href="#">DAS-57</a>
U0401	ECM CAN CIR 1	A, B, C, D, E	<a href="#">DAS-58</a>
U0402	TCM CAN CIR 1	A, B, C, D, E	<a href="#">DAS-60</a>
U0415	VDC CAN CIR 1	A, B, C, D, E	<a href="#">DAS-62</a>
U0433	ICC SENSOR CAN CIRC 2	A, B, C	<a href="#">DAS-64</a>
U1503	SIDE RDR L CAN CIR 2	D, E	<a href="#">DAS-68</a>
U1504	SIDE RDR L CAN CIR 1	D, E	<a href="#">DAS-70</a>
U1505	SIDE RDR R CAN CIR 2	D, E	<a href="#">DAS-72</a>
U1506	SIDE RDR R CAN CIR 1	D, E	<a href="#">DAS-74</a>
C1A03	VHCL SPEED SE CIRC	D, E	<a href="#">DAS-41</a>
C1A00	CONTROL UNIT	A, B, C, D, E	<a href="#">DAS-39</a>

**NOTE:**

With the detection of "U1000" some systems do not perform the fail-safe operation.

A system controlling based on a signal received from the control unit performs fail-safe operation when the communication with the ADAS control unit becomes inoperable.

# ICC SENSOR

< ECU DIAGNOSIS INFORMATION >

[DRIVER ASSISTANCE SYSTEM]

## ICC SENSOR

### Reference Value

INFOID:000000012386693

### VALUES ON THE DIAGNOSIS TOOL

Monitor item	Condition		Value/Status
VHCL SPEED SE	While driving		Value of vehicle speed signal (wheel speed)
YAW RATE	While driving	Vehicle stopped	0.0
		Vehicle turning right	Positive value
		Vehicle turning left	Negative value
PWR SUP MONI	Ignition switch ON		Power supply voltage value of ICC sensor
DISTANCE	Drive the vehicle and activate the ICC system.	When a vehicle ahead is detected	Displays the distance from the preceding vehicle
		When a vehicle ahead is not detected	0.0
RELATIVE SPD	Drive the vehicle and activate the ICC system.	When a vehicle ahead is detected	Displays the relative speed
		When a vehicle ahead is not detected	0.0
LASER OFFSET	<b>NOTE:</b> The item is indicated but not used.		—
LASER HEIGHT	<b>NOTE:</b> The item is indicated but not used.		—
STEERING ANGLE	Ignition switch ON	When setting the steering wheel in straight-ahead position	0.0
		When turning the steering wheel 90° rightward	+90
		When turning the steering wheel 90° leftward	-90
STRG ANGLE SPEED	Ignition switch ON	At the time of turning the steering wheel	Steering wheel turning speed is displayed
L/R ADJUST	Ignition switch ON	At the completion of radar alignment adjustment	Horizontal correction value is displayed
U/D ADJUST	Ignition switch ON	At the completion of radar alignment adjustment	Vertical correction value is displayed
FCW SYSTEM ON	<b>NOTE:</b> The item is indicated, but not used		OFF
FCW SELECT	<b>NOTE:</b> The item is indicated, but not used		—
PFCW SYSTEM ON	<b>NOTE:</b> The item is indicated, but not used		OFF
PFCW SELECT	Engine running	PFCW system set with the information display is ON	ON
		PFCW system set with the information display is OFF	OFF
FEB SW	<b>NOTE:</b> The item is indicated, but not used		—
FEB SELECT	Engine running	PFCW system set with the information display is ON	ON
		PFCW system set with the information display is OFF	OFF

A  
B  
C  
D  
E  
F  
G  
H  
I  
J  
K  
L  
M  
N

DAS

P

# ICC SENSOR

< ECU DIAGNOSIS INFORMATION >

[DRIVER ASSISTANCE SYSTEM]

Monitor item	Condition		Value/Status
MAIN SW	Ignition switch ON	When MAIN switch is pressed	On
		When MAIN switch is not pressed	Off
ICC/ASCD MODE	Engine running	Intelligent Cruise Control System MAIN switch status	On
			Off
SET/COAST SW	Ignition switch ON	When SET/COAST switch is pressed	On
		When SET/COAST switch is not pressed	Off
CANCEL SW	Ignition switch ON	When CANCEL switch is pressed	On
		When CANCEL switch is not pressed	Off
RESUME/ACC SW	Ignition switch ON	When RESUME/ACC SW switch is pressed	On
		When RESUME/ACC SW switch is not pressed	Off
DISTANCE SW	Ignition switch ON	When DISTANCE switch is pressed	On
		When DISTANCE switch is not pressed	Off
BRAKE SW	Ignition switch ON	When brake pedal is depressed	On
		When brake pedal is not depressed	Off
STOP LAMP SW	Ignition switch ON	When brake pedal is depressed	On
		When brake pedal is not depressed	Off
IDLE SW	Engine running	Idling	On
		Except idling (depress accelerator pedal)	Off
CRUISE LAMP	Start the engine and press MAIN switch	ICC system ON (MAIN switch indicator ON)	On
		ICC system OFF (MAIN switch indicator OFF)	Off
OWN VHCL	NOTE: The item is indicated, but not used.	—	Off
VHCL AHEAD	Drive the vehicle and activate the Intelligent Cruise Control System	When a vehicle ahead is detected (vehicle ahead detection indicator ON)	On
		When a vehicle ahead is detected (vehicle ahead detection indicator OFF)	Off
SET DISTANCE	<ul style="list-style-type: none"> <li>• Start the engine and turn the ICC system ON</li> <li>• Press the DISTANCE switch to change the distance setting</li> </ul>	When set to "long"	LONG
		When set to "middle"	MID
		When set to "short"	SHORT
SET VHCL SPD	NOTE: The item is indicated, but not used.	—	—
THRT SENSOR [%]	Engine running	Depress accelerator pedal	Displays the throttle position
VEHICLE AHEAD DETECT	Engine running	—	—
STATIC OBSTACLE DETECT	Indicates [ON/Off] status of static obstacle detection		
BUZZER O/P	Engine running	When the buzzer of the following system operates: <ul style="list-style-type: none"> <li>• Intelligent Cruise Control System</li> <li>• PFCW system</li> <li>• FEB system</li> </ul>	On
		When the buzzer of the following system does not operate: <ul style="list-style-type: none"> <li>• Intelligent Cruise Control System</li> <li>• PFCW system</li> <li>• FEB system</li> </ul>	Off

# ICC SENSOR

< ECU DIAGNOSIS INFORMATION >

[DRIVER ASSISTANCE SYSTEM]

Monitor item	Condition		Value/Status
FUNC ITEM (FCW)	Ignition switch ON	—	—
FUNC ITEM (PFCW)			On
FUNC ITEM (FEB)			
FUNC ITEM (ICC)			
PRESS_ORDER	Engine running	—	
D RANGE SW	Engine running	When the selector lever is in "D" position or manual mode	On
		When the selector lever is in any other than "D" or manual mode	Off
NP RANGE SW	Engine running	When the selector lever is in "N" "P"	On
		When the selector lever is in any other than "N" "P"	Off
PKB SW	Ignition switch ON	When the parking brake is applied	On
		When the parking brake is released	Off
VHCL SPD AT	While driving	—	Value of A/T vehicle speed sensor signal
Shift position	<ul style="list-style-type: none"> <li>• Engine running</li> <li>• While driving</li> </ul>	—	Displays the shift position
Turn signal	NOTE: The item is indicated, but not used	—	Off
SYSTEM CANCEL MESSAGE	Engine running	System cancel display OFF	NO REQ
		System cancel reason is slippery road	SLIP
		System cancel reason is VDC OFF	VDC OFF
DISP VHCL SPD UNIT			
VHCL SPD UNIT	Engine running	Meter indicates km/h	km/h
		Meter indicates mph	mph
ADAS AVAILABLE COND	NOTE: The item is indicated, but not used	—	—
ICC SET STATUS			
ICC MALF			
ADAS MALF	Engine running	ADAS is malfunction	On
		ADAS is not malfunction	Off
STOP LAMP RELAY ON	Engine running	Stop lamp relay is fixed on	On
		Stop lamp relay is not fixed on	Off
STOP LAMP RELAY OFF	Engine running	Stop lamp relay is fixed off	On
		Stop lamp relay is not fixed off	Off
ICC CANCEL	NOTE: The item is indicated, but not used	—	—
ACCEL COM VALUE 1 [m/s <sup>2</sup> ]	Engine running	—	ICC sensor request accel command to ADAS controller
ICC STATUS	Engine running	Intelligent Cruise Control System Off	Off
		Intelligent Cruise Control System On	ICC
		Intelligent Cruise Control System On and vehicle is stopped	STOP1
		Intelligent Cruise Control System On and Driver depressed accelerator pedal	ACCEL

A  
B  
C  
D  
E  
F  
G  
H  
I  
J  
K  
L  
M  
N  
P

DAS

# ICC SENSOR

< ECU DIAGNOSIS INFORMATION >

[DRIVER ASSISTANCE SYSTEM]

Monitor item	Condition	Value/Status
ACCCEL COM VALUE 2	NOTE: The item is indicated, but not used	—
MILEAGE		

## TERMINAL LAYOUT

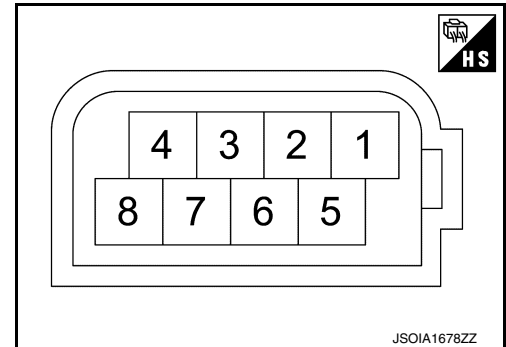

## PHYSICAL VALUES

Terminal No. (Wire color)		Description		Condition	Standard value	Reference value (Approx.)
+	-	Signal name	Input/ Output			
1 (GR)	—	Ground	—	Ignition switch ON	0 - 0.1 V	0 V
2 (L)	—	ITS communication-H	—	—	—	—
3 (Y)		ITS communication-L	—	—	—	—
8 (BG)	—	Ignition power supply	Input	Ignition switch ON	9.5 - 16 V	Battery voltage

## Fail-safe

INFOID:000000012386694

If a malfunction occurs in the ICC sensor, ADAS control unit cancels control, sounds a beep, and turns ON the ICC system warning lamp in the combination meter.

## DTC Inspection Priority Chart

INFOID:000000012386695

If multiple DTCs are detected simultaneously, check them one by one depending on the following DTC inspection priority chart.

Priority	Detected items (DTC)
1	<ul style="list-style-type: none"> <li>U1000: CAN COMM CIRCUIT</li> <li>U1010: CONTROL UNIT (CAN)</li> </ul>
2	<ul style="list-style-type: none"> <li>C1A50: ADAS MALFUNCTION</li> <li>C1A0C: ADAS MSG COUNTER</li> <li>C1A0C: ADAS CRC ERROR</li> </ul>

# ICC SENSOR

< ECU DIAGNOSIS INFORMATION >

[DRIVER ASSISTANCE SYSTEM]

Priority	Detected items (DTC)
3	• C1A01: POWER SUPPLY CIR
	• C1A02: POWER SUPPLY CIR 2
	• C1A04: ABS/TCS/VDC CIRC
	• C1A05: BRAKE SW/STOP L SW
	• C1A06: OPERATION SW CIRC
	• C1A07: CVT CIRCUIT
	• C1A12: LASER BEAM OFFCNTR
	• C1A13: STOP_LAMP_RLY_FIX
	• C1A14: ECM_CIRCUIT
	• C1A16: RADAR STAIN
	• C1A18: LASER AIMING INCOMP
	• C1A21: UNIT HIGH TEMP
	• C1A24: NP RANGE
	• C1A26: ECD MODE MALF
	• C1A27: ECD POWER SUPPLY CIRC
	• C1A39: STRG SEN CIR
	• C1B5D: FEB OPE COUNT LIMIT
	• C10B7: YAW RATE SENSOR
	• U0121: VDC CAN CIR2
	• U153A: TCM CAN CIR 1
• U153B: TCM CAN CIR 2	
• U153D: ECM CAN CIR 2	
• U0126: STRG SEN CAN CIR1	
• U0401: ECM CAN CIR 1	
• U0415: VDC CAN CIR1	
• U0428: STRG SEN CAN CIR2	
4	• C1A03: VEHC_SPEED_SE_CIRC
5	• C1A15: GEAR POSITION
6	• C1A00: CONTROL UNIT
	• C1A17: ICC SENSOR MALF
	• C1A0D: RADAR CAN CIR

## DTC Index

INFOID:000000012386696

### NOTE:

- The details of time display are as per the following.
- 0: The malfunctions that are detected now  
CAN communication system (U1000, U1010)
- 1 - 39: It increases like 0 → 1 → 2 ... 38 → 39 after returning to the normal condition whenever the ignition is switched OFF → ON. It returns to 0 when a malfunction is detected again in the process.
- If it is over 39, it is fixed to 39 until the self-diagnosis results are erased.  
Other than CAN communication system (Other than U1000, U1010)
- 1 - 49: It increases like 0 → 1 → 2 ... 48 → 49 after returning to the normal condition whenever the ignition is switched OFF → ON. It returns to 0 when a malfunction is detected again in the process.
- If it is over 49, it is fixed to 49 until the self-diagnosis results are erased.

DAS

# ICC SENSOR

< ECU DIAGNOSIS INFORMATION >

[DRIVER ASSISTANCE SYSTEM]

×: Applicable

DTC	CONSULT display	ICC system warning lamp	Fail-safe function			Reference
			Intelligent Cruise Control	Predictive Forward Collision Control	Forward Emergency Brake (FEB)	
C1A00	CONTROL UNIT	ON	×	×	×	<a href="#">CCS-70, "DTC Description"</a>
C1A0C	ADAS CAN CIR 1	ON	×	×	×	<a href="#">CCS-117, "DTC Description"</a>
C1A0D	RADAR CAN CIR	ON	×	×	×	<a href="#">CCS-118, "DTC Description"</a>
C1A01	POWER SUPPLY CIR	ON	×	×	×	<a href="#">CCS-71, "DTC Description"</a>
C1A02	POWER SUPPLY CIR2	ON	×	×	×	<a href="#">CCS-71, "DTC Description"</a>
C1A03	VHCL SPEED SE CIRC	ON	×	×	×	<a href="#">CCS-72, "DTC Description"</a>
C1A04	ABS/TCS/DC CIRC	ON	×	×	×	<a href="#">CCS-74, "DTC Description"</a>
C1A05	BRAKE SW/STOP L SW	ON	×	×	×	<a href="#">CCS-75, "DTC Description"</a>
C1A06	OPERATION SW CIRC	ON	×			<a href="#">CCS-79, "DTC Description"</a>
C1A07	CVT CIRCUIT	ON	×	×	×	<a href="#">CCS-114, "DTC Description"</a>
C1A12	LASER BEAM OFFCNTR	ON	×	×	×	<a href="#">CCS-82, "DTC Description"</a>
C1A13	STOP LAMP RLY FIX	ON	×	×	×	<a href="#">CCS-83, "DTC Description"</a>
C1A14	ECM CIRCUIT	ON	×	×	×	<a href="#">CCS-85, "DTC Description"</a>
C10B7	YAW RATE SENSOR	ON	×	×	×	<a href="#">CCS-103, "DTC Description"</a>
C1A15	GEAR POSITION	ON	×	×	×	<a href="#">CCS-87, "DTC Logic"</a>
C1A16	RADAR BLOCKED	ON	×	×	×	<a href="#">CCS-89, "DTC Description"</a>
C1A17	ICC SENSOR MALF	ON	×	×	×	<a href="#">CCS-91, "DTC Description"</a>
C1A18	LASER ALIGNMENT INCMPT	ON	×	×	×	<a href="#">CCS-92, "DTC Description"</a>
C1A21	UNIT HIGH TEMP	ON	×	×	×	<a href="#">CCS-93, "DTC Description"</a>
C1A24	NP RANGE	ON	×	×	×	<a href="#">CCS-94, "DTC Description"</a>



# ICC SENSOR

< ECU DIAGNOSIS INFORMATION >

[DRIVER ASSISTANCE SYSTEM]

DTC	CONSULT display	ICC system warning lamp	Fail-safe function			Reference
			Intelligent Cruise Control	Predictive Forward Collision Control	Forward Emergency Brake (FEB)	
C1A26	ECD MODE MALF	ON	×	×	×	<a href="#">CCS-96, "DTC Description"</a>
C1A27	ECD POWER SUPPLY CIRCUIT	ON	×	×	×	<a href="#">CCS-98, "DTC Description"</a>
C1A39	STRG SENS CIR	ON	×	×	×	<a href="#">CCS-100, "DTC Description"</a>
C1A50	ADAS MALFUNCTION	ON	×	×	×	<a href="#">CCS-102, "DTC Description"</a>
C1B5D	FEB OPE COUNT LIMIT	ON	×	×	×	<a href="#">CCS-101, "DTC Description"</a>
C10B7	YAW RATE SENSOR	ON	×	×	×	<a href="#">CCS-103, "DTC Description"</a>
U153A	TCM CAN CIR 1	ON	×	×	×	<a href="#">CCS-115, "DTC Description"</a>
U153B	TCM CAN CIR 2	ON	×	×	×	<a href="#">CCS-116, "DTC Description"</a>
U153D	ECM CAN CIR 2	ON	×	×	×	<a href="#">CCS-116, "DTC Description"</a>
U0121	VDC CAN CIR2	ON	×	×	×	<a href="#">CCS-104, "DTC Description"</a>
U0126	STRG SEN CAN CIR1	ON	×	×	×	<a href="#">CCS-106, "DTC Description"</a>
U0401	ECM CAN CIR1	ON	×	×	×	<a href="#">CCS-107, "DTC Description"</a>
U0415	VDC CAN CIR1	ON	×	×	×	<a href="#">CCS-108, "DTC Description"</a>
U0428	STRG SEN CAN CIR2	ON	×	×	×	<a href="#">CCS-110, "DTC Description"</a>
U1000	CAN COMM CIRCUIT	ON	×	×	×	<a href="#">CCS-111, "DTC Logic"</a>
U1010	CONTROL UNIT (CAN)	ON	×	×	×	<a href="#">CCS-112, "DTC Logic"</a>

A  
B  
C  
D  
E  
F  
G  
H  
I  
J  
K  
L  
M  
N  
P

DAS

SIDE RADAR LH

Reference Value

INFOID:000000011953159

VALUES ON THE DIAGNOSIS TOOL

**NOTE:**

The following table includes information (items) inapplicable to this vehicle. For information (items) applicable to this vehicle, refer to CONSULT display items.

CONSULT MONITOR ITEM

Monitor Item	Condition	Value/Status
BSW/CTA WARN STATUS	BSW system is normal.	On
	BSW system is malfunctioning.	Off
CTA SYSTEM ON	CTA system is ON.	On
	CTA system is OFF.	Off
BSW STATUS	BSW system is ON.	Off
	BSW system is OFF.	On
VHCL SPD SE	Indicates current vehicle speed	km/h
TURN SIGNAL	Left/right turn signal is ON.	On
	Left/right turn signal is OFF.	Off
SHIFT POSITION	Shows the position of the transmission range switch	P/R/N/D/L
LUMINANCE(LEFT)	Shows radar left luminance level	Hi/Lo
LUMINANCE (RIGHT)	Shows radar right luminance level	Hi/Lo

TERMINAL LAYOUT

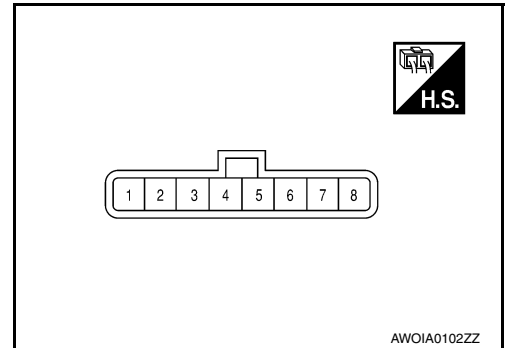

PHYSICAL VALUES

Terminal No. (Wire color)		Description		Condition	Value (Approx.)
+	-	Signal name	Input/Output		
4 (W)	Ground	Blind Spot Warning indicator	Output	Approx. 2 sec. after ignition switch OFF ⇒ ON (bulb check)	6 V
5 (O)	Ground	Ignition power supply	Input	Ignition switch ON	Battery voltage
6 (L)	—	ITS communication high	—	—	—
7 (Y)	—	ITS communication low	—	—	—
8 (B)	Ground	Ground	—	—	0 V

Fail-safe (Side Radar)

INFOID:0000000011953160

FAIL-SAFE CONTROL BY DTC

Blind Spot Warning (BSW)/Rear Cross Traffic Alert (RCTA)

If a malfunction occurs in the side radar, ADAS control unit cancels control and turns ON the Blind Spot Warning indicator (orange) on the combination meter.

TEMPORARY DISABLED STATUS AT BLOCKAGE

Blind Spot Warning (BSW)

When the side radar is blocked, the operation is temporarily canceled. Then the buzzer sounds and the Blind Spot Warning indicator (orange) is turned ON in the combination meter. Also, under the following conditions, the operation may be temporarily canceled:

- The side radar may be blocked by temporary ambient conditions such as splashing water, mist or fog.
- The blocked condition may also be caused by objects such as ice, frost or dirt obstructing the side radar.

Rear Cross Traffic Alert (RCTA)

When the side radar is blocked, the operation is temporarily canceled. Then the buzzer sounds and the Blind Spot Warning indicator (orange) is turned ON in the combination meter. Also, under the following conditions, the operation may be temporarily canceled.

- The side radar may be blocked by temporary ambient conditions such as splashing water, mist or fog.
- The blocked condition may also be caused by objects such as ice, frost or dirt obstructing the side radar.

DTC Inspection Priority Chart

INFOID:0000000011953161

If some DTCs are displayed at the same time, perform inspections one by one based on the following priority chart.

Priority	Detected items (DTC)
1	<ul style="list-style-type: none"> <li>• U1000: CAN COMM CIRCUIT</li> <li>• U1010: CONTROL UNIT (CAN)</li> </ul>
2	<ul style="list-style-type: none"> <li>• U0104: ADAS CAN CIR 1</li> <li>• U0405: ADAS CAN CIR 2</li> </ul>
3	C1B50: SIDE RDR MALFUNCTION
4	<ul style="list-style-type: none"> <li>• C1B51: BSW/BSI IND SHORT CIR</li> <li>• C1B52: BSW/BSI IND OPEN CIR</li> <li>• C1B55: RADAR BLOCKAGE</li> </ul>

DTC Index

INFOID:0000000011953162

×: Applicable

DTC		Fail-safe	Reference page
		Blind Spot Warning/Rear Cross Traffic Alert	
C1B50	SIDE RDR MALFUNCTION	×	<a href="#">DAS-145</a>
C1B51	BSW/BSI IND SHORT CIR	×	<a href="#">DAS-146</a>
C1B52	BSW/BSI IND OPEN CIR	×	<a href="#">DAS-148</a>
C1B55	RADAR BLOCKAGE	×	<a href="#">DAS-150</a>
U1000	CAN COMM CIRCUIT	×	<a href="#">DAS-156</a>
U1010	CONTROL UNIT (CAN)	×	<a href="#">DAS-159</a>
U0104	ADAS CAN CIR1	×	<a href="#">DAS-152</a>
U0405	ADAS CAN CIR2	×	<a href="#">DAS-154</a>

A  
B  
C  
D  
E  
F  
G  
H  
I  
J  
K  
L  
M  
N  
P



SIDE RADAR RH

Reference Value

INFOID:000000011953163

VALUES ON THE DIAGNOSIS TOOL

**NOTE:**

The following table includes information (items) inapplicable to this vehicle. For information (items) applicable to this vehicle, refer to CONSULT display items.

CONSULT MONITOR ITEM

Monitor Item	Condition	Value/Status
BSW/CTA WARN STATUS	BSW system is normal.	On
	BSW system is malfunctioning.	Off
CTA SYSTEM ON	CTA system is ON.	On
	CTA system is OFF.	Off
BSW STATUS	BSW system is ON.	Off
	BSW system is OFF.	On
VHCL SPD SE	Indicates current vehicle speed	km/h
TURN SIGNAL	Left/right turn signal is ON.	On
	Left/right turn signal is OFF.	Off
SHIFT POSITION	Shows the position of the transmission range switch	P/R/N/D
LUMINANCE(LEFT)	Shows radar left luminance level	Hi/Lo
LUMINANCE (RIGHT)	Shows radar right luminance level	Hi/Lo

TERMINAL LAYOUT

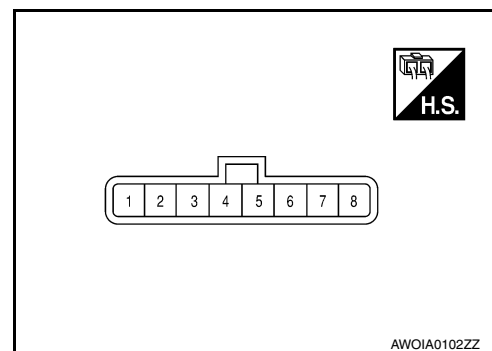

PHYSICAL VALUES

Terminal No. (Wire color)		Description		Condition	Value (Approx.)
+	-	Signal name	Input/ Output		
3 (B)	Ground	Right/Left switching signal	Input	—	0 V
4 (P)	Ground	Blind Spot Warning indicator	Output	Approx. 2 sec. after ignition switch OFF ⇒ ON (bulb check)	6 V
5 (O)	Ground	Ignition power supply	Input	Ignition switch ON	Battery voltage
6 (L)	—	ITS communication high	—	—	—
7 (Y)	—	ITS communication low	—	—	—
8 (B)	Ground	Ground	—	—	0 V

Fail-safe (Side Radar)

INFOID:0000000011953164

FAIL-SAFE CONTROL BY DTC

Blind Spot Warning (BSW)/Rear Cross Traffic Alert (RCTA)

If a malfunction occurs in the side radar, ADAS control unit cancels control and turns ON the Blind Spot Warning indicator (orange) on the combination meter.

TEMPORARY DISABLED STATUS AT BLOCKAGE

Blind Spot Warning (BSW)

When the side radar is blocked, the operation is temporarily canceled. Then the buzzer sounds and the Blind Spot Warning indicator (orange) is turned ON in the combination meter. Also, under the following conditions, the operation may be temporarily canceled:

- The side radar may be blocked by temporary ambient conditions such as splashing water, mist or fog.
- The blocked condition may also be caused by objects such as ice, frost or dirt obstructing the side radar.

Rear Cross Traffic Alert (RCTA)

When the side radar is blocked, the operation is temporarily canceled. Then the buzzer sounds and the Blind Spot Warning indicator (orange) is turned ON in the combination meter. Also, under the following conditions, the operation may be temporarily canceled.

- The side radar may be blocked by temporary ambient conditions such as splashing water, mist or fog.
- The blocked condition may also be caused by objects such as ice, frost or dirt obstructing the side radar.

DTC Inspection Priority Chart

INFOID:0000000011953165

If some DTCs are displayed at the same time, perform inspections one by one based on the following priority chart.

Priority	Detected items (DTC)
1	<ul style="list-style-type: none"> <li>• U1000: CAN COMM CIRCUIT</li> <li>• U1010: CONTROL UNIT (CAN)</li> </ul>
2	<ul style="list-style-type: none"> <li>• U0104: ADAS CAN CIR 1</li> <li>• U0405: ADAS CAN CIR 2</li> </ul>
3	C1B50: SIDE RDR MALFUNCTION
4	<ul style="list-style-type: none"> <li>• C1B51: BSW/BSI IND SHORT CIR</li> <li>• C1B52: BSW/BSI IND OPEN CIR</li> <li>• C1B55: RADAR BLOCKAGE</li> </ul>

DTC Index

INFOID:0000000011953166

×: Applicable

DTC		Fail-safe	Reference page
		Blind Spot Warning/Rear Cross Traffic Alert	
C1B50	SIDE RDR MALFUNCTION	×	<a href="#">DAS-145</a>
C1B51	BSW/BSI IND SHORT CIR	×	<a href="#">DAS-146</a>
C1B52	BSW/BSI IND OPEN CIR	×	<a href="#">DAS-148</a>
C1B55	RADAR BLOCKAGE	×	<a href="#">DAS-150</a>
U1000	CAN COMM CIRCUIT	×	<a href="#">DAS-157</a>
U1010	CONTROL UNIT (CAN)	×	<a href="#">DAS-160</a>
U0104	ADAS CAN CIR1	×	<a href="#">DAS-152</a>
U0405	ADAS CAN CIR2	×	<a href="#">DAS-154</a>

A  
B  
C  
D  
E  
F  
G  
H  
I  
J  
K  
L  
M  
N  
P



< WIRING DIAGRAM >

WIRING DIAGRAM

DRIVER ASSISTANCE SYSTEMS

Wiring Diagram

INFOID:0000000011953167

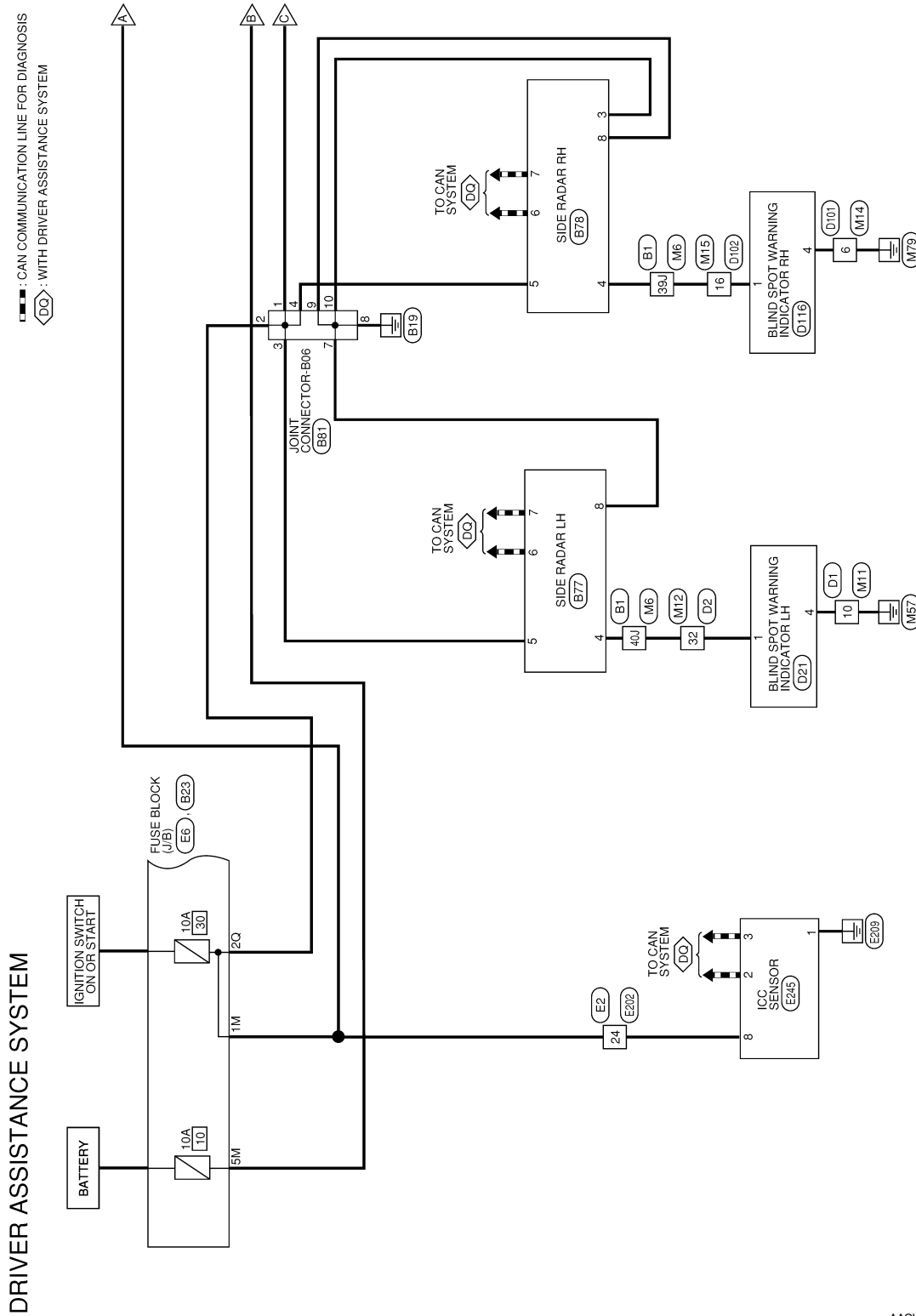

AAOWA0105GB

# DRIVER ASSISTANCE SYSTEMS

## [DRIVER ASSISTANCE SYSTEM]

< WIRING DIAGRAM >

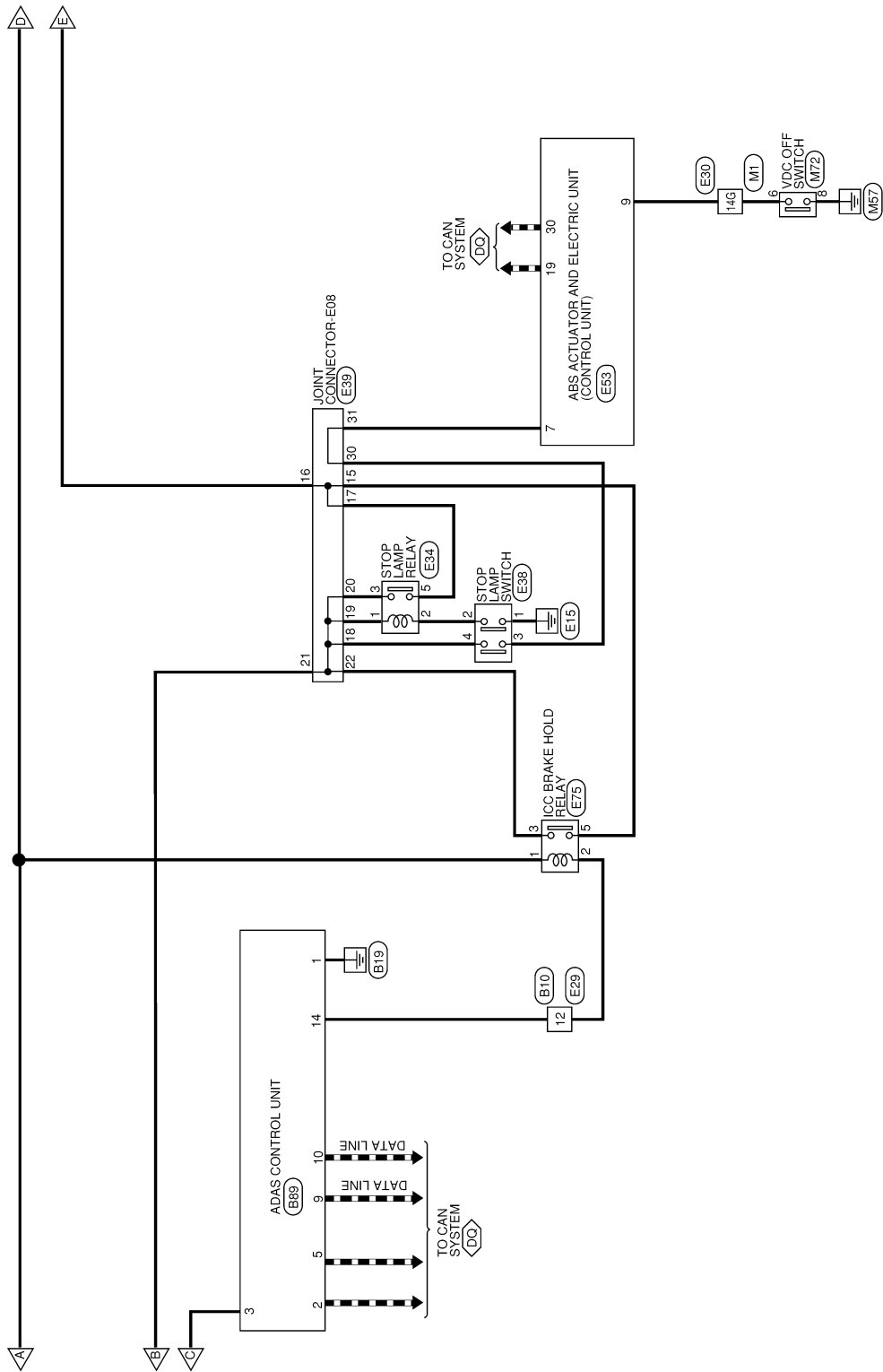

AAOWA0106GB

A  
B  
C  
D  
E  
F  
G  
H  
I  
J  
K  
L  
M  
N  
P

DAS

# DRIVER ASSISTANCE SYSTEMS

## [DRIVER ASSISTANCE SYSTEM]

< WIRING DIAGRAM >

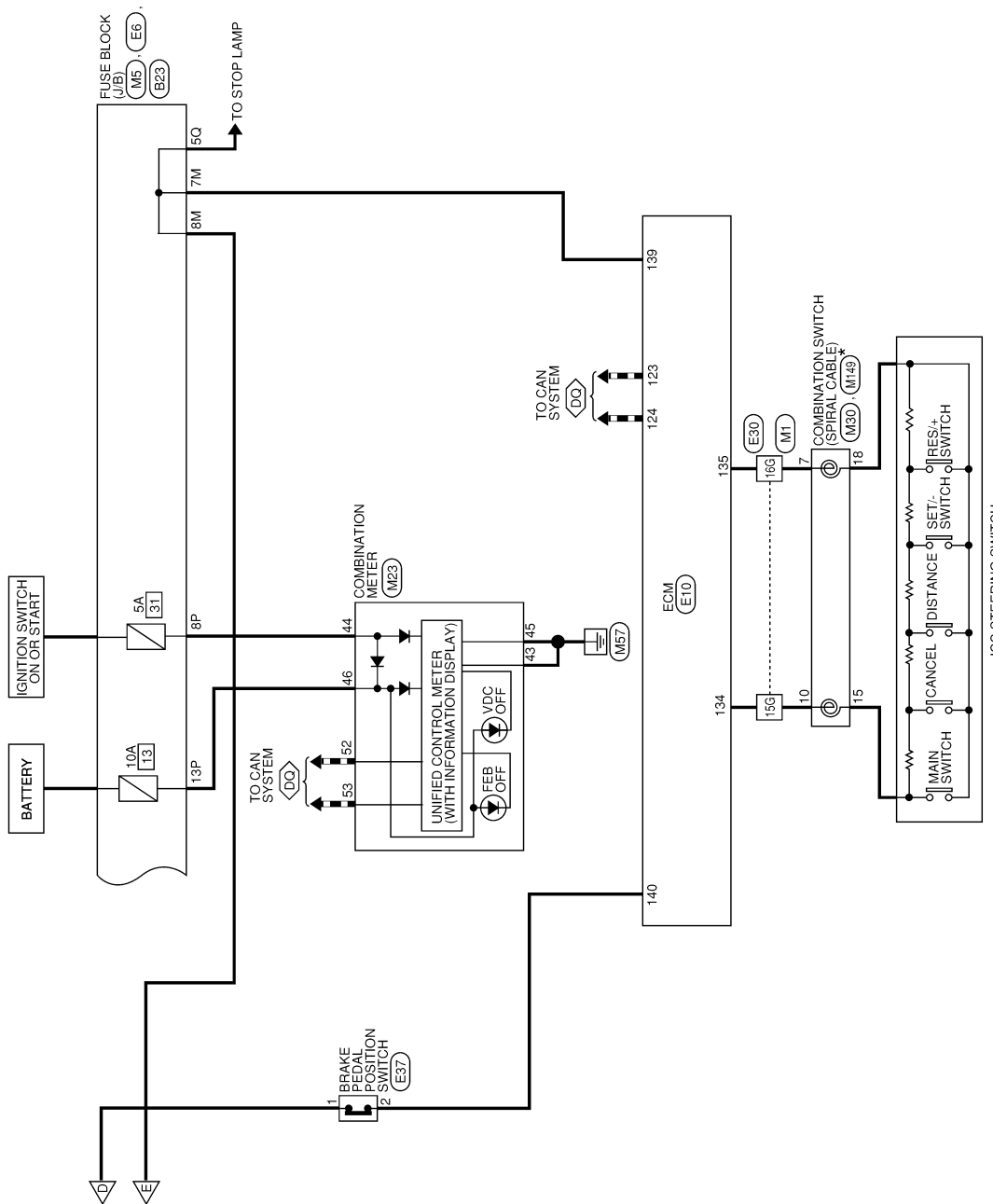

\*: This connector is not shown in "Harness Layout"

AAOWA0107GB



# DRIVER ASSISTANCE SYSTEMS

## [DRIVER ASSISTANCE SYSTEM]

< WIRING DIAGRAM >

### DRIVER ASSISTANCE SYSTEM CONNECTORS

Connector No.	M1
Connector Name	WIRE TO WIRE
Connector Type	TH80FW-CS16-TM4
Connector Color	WHITE

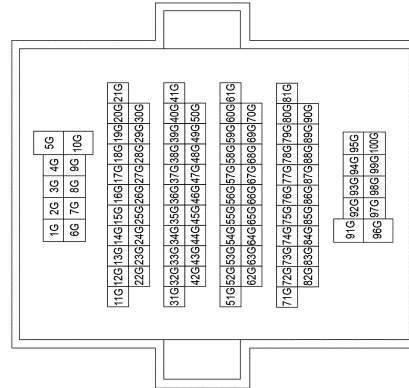

Terminal No.	Color of Wire	Signal Name
14G	LG	-
15G	BG	-
16G	R	-

Connector No.	M5
Connector Name	FUSE BLOCK (J/B)
Connector Type	NS16FW-CS
Connector Color	WHITE



Terminal No.	Color of Wire	Signal Name
8P	BR	-
13P	G	-

Connector No.	M6
Connector Name	WIRE TO WIRE
Connector Type	TH80FDGY-CS16-TM4
Connector Color	GRAY

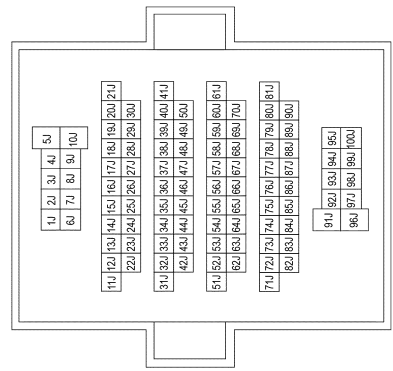

Terminal No.	Color of Wire	Signal Name
38U	P	-
40U	W	-

Connector No.	M11
Connector Name	WIRE TO WIRE
Connector Type	NS16MW-CS
Connector Color	WHITE

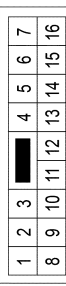

Terminal No.	Color of Wire	Signal Name
10	B	-

Connector No.	M12
Connector Name	WIRE TO WIRE
Connector Type	TH40MW-NH
Connector Color	WHITE

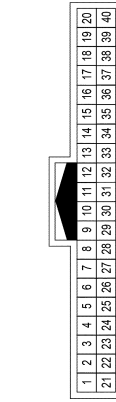

Terminal No.	Color of Wire	Signal Name
32	W	-

Connector No.	M14
Connector Name	WIRE TO WIRE
Connector Type	NS10MW-CS
Connector Color	WHITE

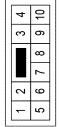

Terminal No.	Color of Wire	Signal Name
6	GR	-

Connector No.	M15
Connector Name	WIRE TO WIRE
Connector Type	TH24MW-NH
Connector Color	WHITE



Terminal No.	Color of Wire	Signal Name
16	P	-

A  
B  
C  
D  
E  
F  
G  
H  
I  
J  
K  
L  
M  
N  
P



AAOIA00363GB

# DRIVER ASSISTANCE SYSTEMS

## [DRIVER ASSISTANCE SYSTEM]

< WIRING DIAGRAM >

Connector No.	E6
Connector Name	FUSE BLOCK (J/B)
Connector Type	NS10FW-CS
Connector Color	WHITE



4M	3M	2M	1M
10M	9M	8M	7M
6M	5M		

Terminal No.	Color of Wire	Signal Name
1M	BG	-
5M	P	-
7M	GR	-
8M	W	-

Connector No.	E10
Connector Name	ECM
Connector Type	RH24FB-RZ8-L-LH
Connector Color	BLACK



121	125	129	133	137	141	145	149
122	126	130	134	138	142	146	150
123	127	131	135	139	143	147	151
124	128	132	136	140	144	148	152

Terminal No.	Color of Wire	Signal Name
123	P	CAN-L
124	L	CAN-H
134	G	ASCD/CC STEERING SWITCH
135	R	ASCD/CC STEERING SWITCH GROUND
139	GR	STOP LAMP SWITCH
140	BR	BRAKE PEDAL POSITION SWITCH

Connector No.	M12
Connector Name	VDC OFF SWITCH
Connector Type	TH08FB-NH
Connector Color	BLACK



4	3	2	1
8	7	6	5

Terminal No.	Color of Wire	Signal Name
6	LG	-
8	B	-

Connector No.	M149
Connector Name	COMBINATION SWITCH (SPIRAL CABLE)
Connector Type	TK08FGY-X
Connector Color	GRAY



22	21	20	19	18	17	16	15
----	----	----	----	----	----	----	----

Terminal No.	Color of Wire	Signal Name
15	W	-
18	BR	-

Connector No.	E2
Connector Name	WIRE TO WIRE
Connector Type	TH24MW-NH
Connector Color	WHITE



1	2	3	4	5	6	7	8	9	10	11	12
13	14	15	16	17	18	19	20	21	22	23	24

Terminal No.	Color of Wire	Signal Name
24	BG	-

Connector No.	M23
Connector Name	COMBINATION METER
Connector Type	TH16FW-NH
Connector Color	WHITE



41	42	43	44	45	46	47	48
49	50	51	52	53	54	55	56

Terminal No.	Color of Wire	Signal Name
43	B	GND1
44	BR	POWER (IGN)
45	B	GND2
46	G	POWER (BAT)
52	P	CAN-L
53	L	CAN-H

Connector No.	M30
Connector Name	COMBINATION SWITCH (SPIRAL CABLE)
Connector Type	TK08FGY-1V
Connector Color	GRAY



10	9	8	7
14	13	12	11

Terminal No.	Color of Wire	Signal Name
7	R	-
10	BG	-

AAOIA0364GB

# DRIVER ASSISTANCE SYSTEMS

< WIRING DIAGRAM >

[DRIVER ASSISTANCE SYSTEM]

2	R	-
3	LG	-
4	P	-

Connector No.	E39
Connector Name	JOINT CONNECTOR-E08
Connector Type	BJ30FW
Connector Color	WHITE

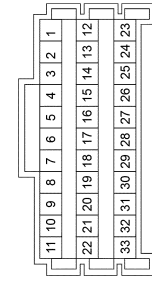

Terminal No.	Color of Wire	Signal Name
15	W	-
16	W	-
17	W	-
18	P	-
19	P	-
20	P	-
21	P	-
22	P	-
30	LG	-
31	LG	-

Connector No.	E53
Connector Name	ABS ACTUATOR AND ELECTRIC UNIT (CONTROL UNIT) (WITH INTELLIGENT CRUISE CONTROL SYSTEM)
Connector Type	SAZ34FB-HS2-SJZ2-UH
Connector Color	BLACK

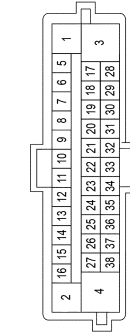

Terminal No.	Color of Wire	Signal Name
7	LG	BLS
9	V	VDC OFF
19	L	CAN-H
30	P	CAN-L

Connector No.	E34
Connector Name	STOP LAMP RELAY
Connector Type	MS02FL-M2-LC
Connector Color	BLUE

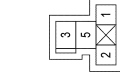

Terminal No.	Color of Wire	Signal Name
1	P	-
2	R	-
3	P	-
5	W	-

Connector No.	E37
Connector Name	BRAKE PEDAL POSITION SWITCH
Connector Type	M02FBR-LC
Connector Color	BROWN



Terminal No.	Color of Wire	Signal Name
1	BG	-
2	BR	-

Connector No.	E38
Connector Name	STOP LAMP SWITCH
Connector Type	M04FW-LC
Connector Color	WHITE

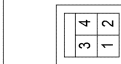

Terminal No.	Color of Wire	Signal Name
1	B	-

Connector No.	E29
Connector Name	WIRE TO WIRE
Connector Type	NS16FW-CS
Connector Color	WHITE

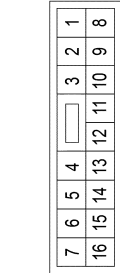

Terminal No.	Color of Wire	Signal Name
12	W	-

Connector No.	E30
Connector Name	WIRE TO WIRE
Connector Type	TH80MW-CS16-TM4
Connector Color	WHITE

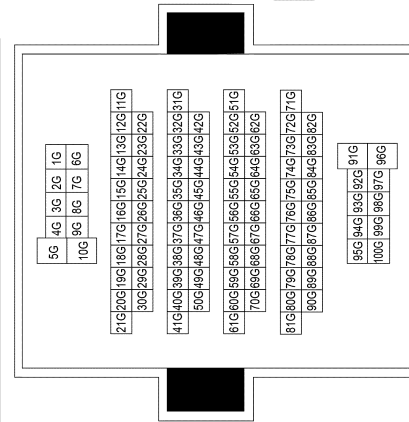

Terminal No.	Color of Wire	Signal Name
14G	V	-
15G	G	-
16G	R	-

AAOIA00365GB

A  
B  
C  
D  
E  
F  
G  
H  
I  
J  
K  
L  
M  
N  
P



# DRIVER ASSISTANCE SYSTEMS

< WIRING DIAGRAM >

[DRIVER ASSISTANCE SYSTEM]

Connector No.	B23
Connector Name	FUSE BLOCK (J/B)
Connector Type	NS08FW-CS
Connector Color	WHITE

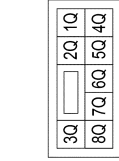

Terminal No.	Color of Wire	Signal Name
2Q	BG	-
5Q	L	-

Connector No.	B77
Connector Name	SIDE RADAR LH
Connector Type	JAD08FB-5P
Connector Color	BLACK

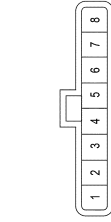

Terminal No.	Color of Wire	Signal Name
4	W	-
5	O	-
6	L	-
7	Y	-
8	B	-

3	Y	ITS CAN-H
8	BG	IGN

  

Connector No.	B1
Connector Name	WIRE TO WIRE
Connector Type	TH80MDGY-CS16-TM4
Connector Color	GRAY

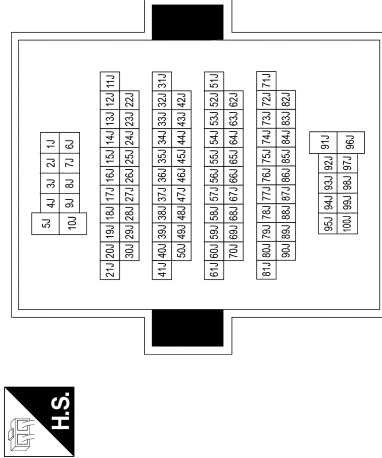

Terminal No.	Color of Wire	Signal Name
38J	P	-
40J	W	-

Connector No.	B10
Connector Name	WIRE TO WIRE
Connector Type	NS16MW-CS
Connector Color	WHITE

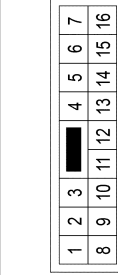

Terminal No.	Color of Wire	Signal Name
12	W	-

Connector No.	E75
Connector Name	ICC BRAKE HOLD RELAY
Connector Type	MS02FL-M2-LC
Connector Color	BLUE

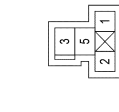

Terminal No.	Color of Wire	Signal Name
1	BG	-
2	W	-
3	P	-
5	W	-

Connector No.	E202
Connector Name	WIRE TO WIRE
Connector Type	TH24FW-NH
Connector Color	WHITE

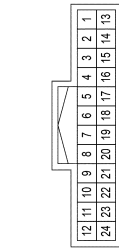

Terminal No.	Color of Wire	Signal Name
24	BG	-

Connector No.	E245
Connector Name	ICC SENSOR
Connector Type	AAZ08FB
Connector Color	BLACK

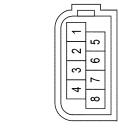

Terminal No.	Color of Wire	Signal Name
1	GR	GND
2	L	ITS CAN-H

# DRIVER ASSISTANCE SYSTEMS

## [DRIVER ASSISTANCE SYSTEM]

< WIRING DIAGRAM >

Connector No.	D2
Connector Name	WIRE TO WIRE
Connector Type	TH40FW-NH
Connector Color	WHITE

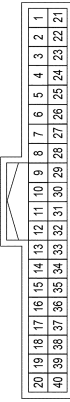
Terminal No.	Color of Wire	Signal Name
32	P	-

Connector No.	D21
Connector Name	BLIND SPOT WARNING INDICATOR LH
Connector Type	TH04MW-NH
Connector Color	WHITE

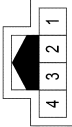

Terminal No.	Color of Wire	Signal Name
1	P	-
4	B	-

Connector No.	D101
Connector Name	WIRE TO WIRE
Connector Type	NS10FW-CS
Connector Color	WHITE

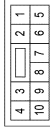
Terminal No.	Color of Wire	Signal Name
6	B	-

Connector No.	B89
Connector Name	ADAS CONTROL UNIT
Connector Type	TH24FW-NH
Connector Color	WHITE

Terminal No.	Color of Wire	Signal Name
1	B	GND
2	L	ITS CAN-H
3	BG	IGN
5	Y	ITS CAN-L
9	L	CAN-H
10	P	CAN-L
14	W	BRAKE RELAY

Connector No.	D1
Connector Name	WIRE TO WIRE
Connector Type	NS16FW-CS
Connector Color	WHITE

Terminal No.	Color of Wire	Signal Name
10	B	-

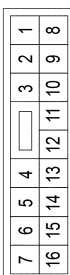
Connector No.	B78
Connector Name	SIDE RADAR RH
Connector Type	JAD08FB-6P
Connector Color	BLACK

Terminal No.	Color of Wire	Signal Name
3	B	-
4	P	-
5	O	-
6	L	-
7	Y	-
8	B	-

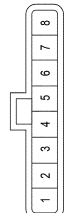
Connector No.	B81
Connector Name	JOINT CONNECTOR-B06
Connector Type	A12FL
Connector Color	BLUE



Terminal No.	Color of Wire	Signal Name
1	BG	-
2	BG	-
3	O	-
4	O	-
7	B	-
8	B	-
9	B	-
10	B	-

AAOIA0367GB

A  
B  
C  
D  
E  
F  
G  
H  
I  
J  
K  
L  
M  
N  
P

DAS

# DRIVER ASSISTANCE SYSTEMS

< WIRING DIAGRAM >

[DRIVER ASSISTANCE SYSTEM]

Connector No.	D102
Connector Name	WIPE TO WIRE
Connector Type	TH24FW-NH
Connector Color	WHITE

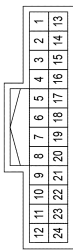

Terminal No.	16	Color of Wire	R	Signal Name	-
--------------	----	---------------	---	-------------	---

Connector No.	D116
Connector Name	BLIND SPOT WARNING INDICATOR RH
Connector Type	TH04MW-NH
Connector Color	WHITE

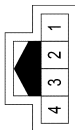

Terminal No.	1	Color of Wire	R	Signal Name	-
4		B			

AAOIA0368GB

# DIAGNOSIS AND REPAIR WORK FLOW

< BASIC INSPECTION >

[DRIVER ASSISTANCE SYSTEM]

## BASIC INSPECTION

### DIAGNOSIS AND REPAIR WORK FLOW

Work Flow

INFOID:0000000011953168

#### OVERALL SEQUENCE

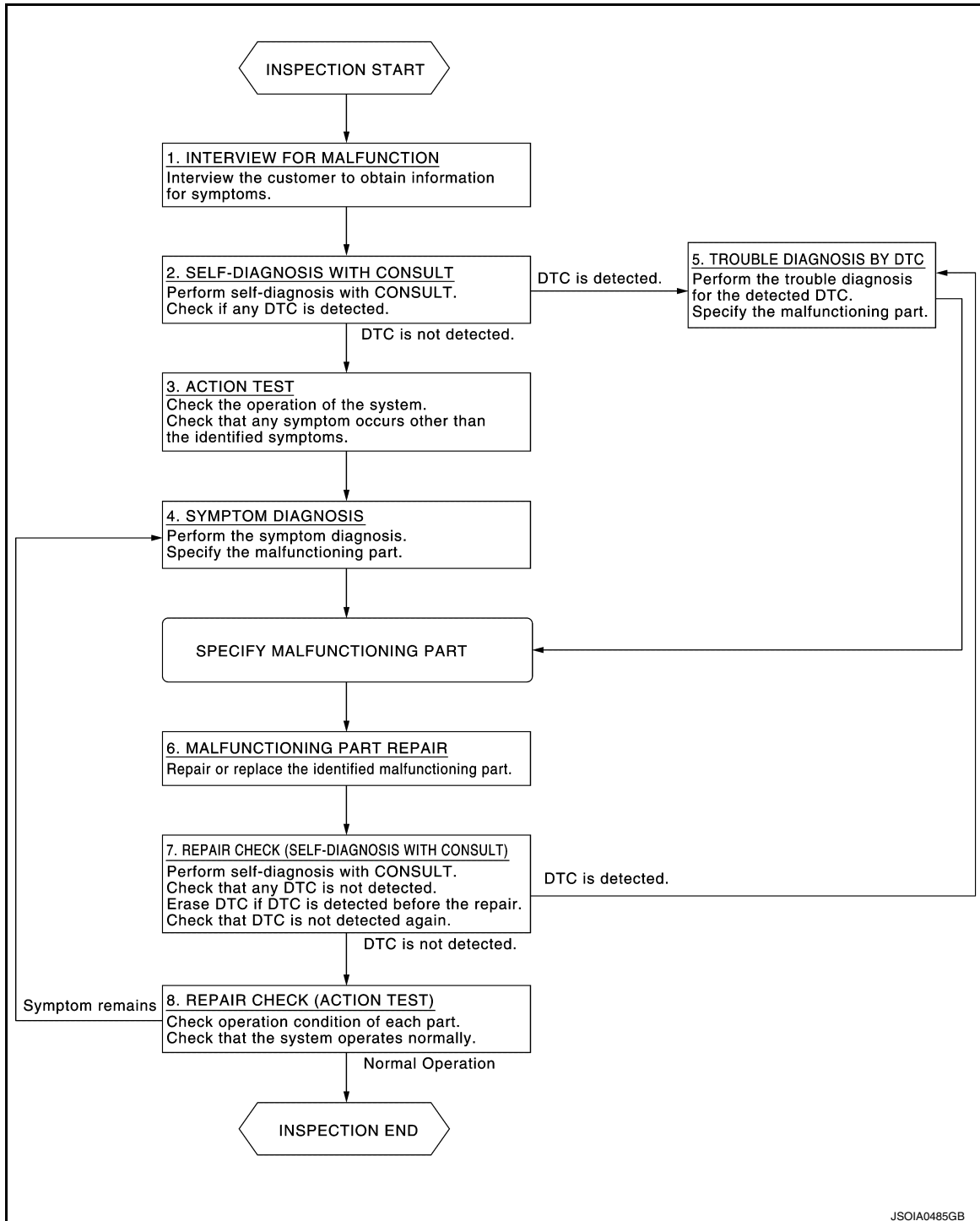

#### DETAILED FLOW

##### 1. INTERVIEW FOR MALFUNCTION

It is important to clarify the customer's concerns before starting the inspection. Interview the customer about the concerns carefully and understand the symptoms fully.

A  
B  
C  
D  
E  
F  
G  
H  
I  
J  
K  
L  
M  
N  
P

DAS

# DIAGNOSIS AND REPAIR WORK FLOW

[DRIVER ASSISTANCE SYSTEM]

< BASIC INSPECTION >

## NOTE:

The customers are not professionals. Never assume that “maybe the customer means...” or “maybe the customer mentioned this symptom”.

>> GO TO 2.

## 2. SELF-DIAGNOSIS WITH CONSULT

---

### CONSULT

1. Perform “All DTC Reading” mode.
2. Check if the DTC is detected in the “Self Diagnostic Result” of the following:
  - “ICC/ADAS”
  - “LASER/RADAR”
  - “SIDE RADAR LEFT”
  - “SIDE RADAR RIGHT”

Is any DTC detected?

YES >> GO TO 5.

NO >> GO TO 3.

## 3. ACTION TEST

---

1. Perform the system action test to check the operation status of the following:
  - BSW: Refer to [DAS-143, "BLIND SPOT WARNING : Description"](#).
  - RCTA: Refer to [DAS-144, "RCTA : Description"](#).
2. Check if any other malfunctions occur.

>> GO TO 4.

## 4. SYMPTOM DIAGNOSIS

---

Perform the applicable diagnosis according to the diagnosis chart by symptom. Refer to [DAS-164, "Symptom Table"](#).

>> GO TO 6.

## 5. TROUBLE DIAGNOSIS BY DTC

---

### CONSULT

1. Check the DTC in the “Self Diagnostic Result”.
2. Perform trouble diagnosis for the following detected DTC:
  - “ICC/ADAS”: Refer to [DAS-117, "DTC Index"](#).
  - “LASER/RADAR”: Refer to [CCS-46, "DTC Index"](#).
  - “SIDE RADAR LEFT”: Refer to [DAS-127, "DTC Index"](#).
  - “SIDE RADAR RIGHT”: Refer to [DAS-129, "DTC Index"](#).

### NOTE:

If “DTC U1000” is detected, first diagnose the CAN communication system or ITS communication system.

>> GO TO 6.

## 6. MALFUNCTIONING PART REPAIR

---

Repair or replace the identified malfunctioning parts.

>> GO TO 7.

## 7. REPAIR CHECK (SELF-DIAGNOSIS WITH CONSULT)

---

1. Erase “Self Diagnostic Result”.
2. Perform “All DTC Reading” mode after repairing or replacing the specific items.
3. Check if any DTC is detected in self-diagnosis results of the following:
  - “ICC/ADAS”
  - “LASER/RADAR”
  - “SIDE RADAR LEFT”
  - “SIDE RADAR RIGHT”



# DIAGNOSIS AND REPAIR WORK FLOW

[DRIVER ASSISTANCE SYSTEM]

< BASIC INSPECTION >

Is any DTC detected?

YES >> GO TO 5.

NO >> GO TO 8.

## 8.REPAIR CHECK (ACTION TEST)

Perform the following system action test. Check that the malfunction symptom is solved or no other symptoms occur.

- BSW: Refer to [DAS-143. "BLIND SPOT WARNING : Description"](#).
- RCTA: Refer to [DAS-144. "RCTA : Description"](#).

Is there a malfunction symptom?

YES >> GO TO 4.

NO >> Inspection End.

A  
B  
C  
D  
E  
F  
G  
H  
I  
J  
K  
L  
M  
N  
P

DAS

## ADDITIONAL SERVICE WHEN REPLACING ICC SENSOR

< BASIC INSPECTION >

[DRIVER ASSISTANCE SYSTEM]

---

### ADDITIONAL SERVICE WHEN REPLACING ICC SENSOR

#### Description

INFOID:000000011953169

- Always perform the radar alignment after removing and installing or replacing the ICC sensor.  
**CAUTION:**  
**The system does not operate normally unless the laser beam aiming adjustment is performed. Always perform it.**
- Perform the PFCW system action test and check that the PFCW system operates normally.

#### Work Procedure

INFOID:000000011953170

#### 1. RADAR ALIGNMENT

---

Perform the radar alignment. Refer to [CCS-59. "Description"](#).

>> GO TO 2.

#### 2. ICC SYSTEM ACTION TEST

- 
1. Perform the ICC system action test. Refer to [CCS-66. "Description"](#).
  2. Check that the ICC system operates normally.

>> Inspection End.

# ACTION TEST

< BASIC INSPECTION >

[DRIVER ASSISTANCE SYSTEM]

## ACTION TEST

### BLIND SPOT WARNING

#### BLIND SPOT WARNING : Description

INFOID:000000011953171

Always perform the Blind Spot Warning system action test to check that the system operates normally after replacing the side radar LH/RH or repairing any Blind Spot Warning system malfunction.

**WARNING:**

Be careful of traffic conditions and safety around the vehicle when performing road test.

**CAUTION:**

Fully understand the following items well before the road test;

- Precautions: Refer to [DAS-82, "Blind Spot Warning System Service"](#).
- System description for Blind Spot Warning: Refer to [DAS-90, "BSW : System Description"](#).
- Normal operating condition: Refer to [DAS-170, "Description"](#).

#### BLIND SPOT WARNING : Work Procedure

INFOID:000000011953172

**WARNING:**

Be careful of traffic conditions and safety around the vehicle when performing road test.

**CAUTION:**

Fully understand the following items well before the road test;

- Precautions: Refer to [DAS-82, "Blind Spot Warning System Service"](#).
- System description for Blind Spot Warning: Refer to [DAS-90, "BSW : System Description"](#).
- Normal operating condition: Refer to [DAS-170, "Description"](#).

#### 1. CHECK BSW SYSTEM SETTING

1. Start the engine.
2. Check that the BSW system setting can be enabled/disabled on the integral switch.
3. Turn ignition switch OFF and wait for 5 seconds or more.
4. Check that the previous setting is saved when the engine starts again.

>> GO TO 2.

#### 2. BSW SYSTEM ACTION TEST

1. Enable the setting of the BSW system on the integral switch.
2. Check BSW operation according to the following table:

Vehicle condition/ Driver operation			Action			
Vehicle speed (Approx.)	Turn signal condition	Status of vehicle detection within detection area	Indication on the Blind Spot Warning indicator	Indication on the combination meter	Indicator color	Buzzer
Less than 18 MPH (29 km/h)	—	—	OFF	ON	White	OFF
	—	Vehicle is absent.	OFF	ON	White	OFF
20 MPH (32 km/h) or more	OFF	Vehicle is detected.	ON	ON	White	OFF
	ON (vehicle detected direction)	Before turn signal operates Vehicle is detected.	Blink	Blink	Yellow (Blink)	Short continuous beeps
		Vehicle is detected after turn signal operates.	Blink	Blink	Yellow (Blink)	OFF

>> Inspection End.

### RCTA

A  
B  
C  
D  
E  
F  
G  
H  
I  
J  
K  
L  
M  
N  
P

DAS

# ACTION TEST

< BASIC INSPECTION >

[DRIVER ASSISTANCE SYSTEM]

## RCTA : Description

INFOID:000000011953173

Always perform the RCTA system action test to check that the system operates normally after replacing the side radar LH/RH or repairing any BSW/RCTA system malfunction.

**WARNING:**

Be careful of traffic conditions and safety around the vehicle when performing road test.

**CAUTION:**

Fully understand the following items well before the road test;

- Precautions: Refer to [DAS-82, "Blind Spot Warning System Service"](#).
- System description for RCTA: Refer to [DAS-92, "RCTA : System Description"](#).
- Normal operating condition: Refer to [DAS-170, "Description"](#).

## RCTA : Work Procedure

INFOID:000000011953174

**WARNING:**

Be careful of traffic conditions and safety around the vehicle when performing road test.

**CAUTION:**

Fully understand the following items well before the road test;

- Precautions: Refer to [DAS-82, "Blind Spot Warning System Service"](#).
- System description for RCTA: Refer to [DAS-92, "RCTA : System Description"](#).
- Normal operating condition: Refer to [DAS-170, "Description"](#).

### 1. CHECK BSW/RCTA SYSTEM SETTING

1. Start the engine.
2. Check that the BSW system setting can be enabled/disabled on the integral switch.
3. Turn ignition switch OFF and wait for 30 seconds or more.
4. Check that the previous setting is saved when the engine starts again.

>> GO TO 2.

### 2. ACTION TEST FOR RCTA

1. Enable the setting of the RCTA system on the integral switch.
2. Check the RCTA operation according to the following table:

Vehicle condition		Action	Buzzer
• R range • 5 MPH (8 km/h)	If the radar detects an approaching vehicle from the side.	<ul style="list-style-type: none"><li>• Chime sounds (single beep)</li><li>• Flashes Blind Spot Warning indicator on the side that the approaching vehicle is detected</li><li>• Yellow rectangular frame appears in the display.</li></ul>	Single beep
	No approaching vehicle	No action	—

>> Inspection End.

# C1B50 SIDE RADAR MALFUNCTION

< DTC/CIRCUIT DIAGNOSIS >

[DRIVER ASSISTANCE SYSTEM]

## DTC/CIRCUIT DIAGNOSIS

### C1B50 SIDE RADAR MALFUNCTION

#### DTC Description

INFOID:0000000011953175

#### DTC DETECTION LOGIC

DTC No.	CONSULT screen terms (Trouble diagnosis content)	DTC detection condition	
C1B50	SIDE RDR MALFUNCTION (Side radar malfunction)	Diagnosis condition	When ignition switch is ON.
		Signal (terminal)	–
		Threshold	Side radar malfunction
		Diagnosis delay time	–

#### POSSIBLE CAUSE

Side radar

#### FAIL-SAFE

The following systems are canceled:

- Blind Spot Warning (BSW)
- Rear Cross Traffic Alert (RCTA)

#### DTC CONFIRMATION PROCEDURE

##### 1. PERFORM DTC CONFIRMATION PROCEDURE

###### CONSULT

1. Start the engine.
2. Select "All DTC Reading" mode.
3. Check if "C1B50" is detected as the current malfunction in "Self Diagnostic Result" mode of "SIDE RADAR RIGHT/LEFT".

###### Is the "C1B50" detected as the current malfunction?

- YES >> Refer to [DAS-145, "Diagnosis Procedure"](#).
- NO-1 >> To check malfunction symptom before repair: Refer to [GI-41, "Intermittent Incident"](#).
- NO-2 >> Confirmation after repair: Inspection End.

#### Diagnosis Procedure

INFOID:0000000011953176

##### 1. PERFORM SELF DIAGNOSTIC RESULT

###### CONSULT

1. Turn ignition switch ON.
2. Select "Self Diagnostic Result" mode of "SIDE RADAR LEFT/RIGHT".
3. Select "ERASE".
4. Turn ignition switch OFF.
5. Turn ignition switch ON.
6. Check if any DTC other than "C1B50" is detected in "Self Diagnostic Result" mode of "SIDE RADAR LEFT/RIGHT".

###### Is any DTC detected?

- YES >> Perform diagnosis on the detected DTC and repair or replace the malfunctioning part. Refer to [DAS-129, "DTC Index"](#) (Side Radar Right) or [DAS-127, "DTC Index"](#) (Side Radar Left).
- NO >> Replace the faulty side radar. Refer to [DAS-177, "Removal and Installation"](#).

# C1B51 BLIND SPOT WARNING INDICATOR SHORT CIRCUIT

< DTC/CIRCUIT DIAGNOSIS >

[DRIVER ASSISTANCE SYSTEM]

## C1B51 BLIND SPOT WARNING INDICATOR SHORT CIRCUIT

### DTC Description

INFOID:000000011953177

### DTC DETECTION LOGIC

DTC No.	CONSULT screen terms (Trouble diagnosis content)	DTC detection condition	
C1B51	BSW/BSI IND SHORT CIR (Blind Spot Warning indicator short circuit)	Diagnosis condition	When ignition switch is ON.
		Signal (terminal)	–
		Threshold	Short circuit in Blind Spot Warning indicator circuit is detected. (Over current is detected)
		Diagnosis delay time	–

### POSSIBLE CAUSE

- Blind Spot Warning indicator circuit
- Blind Spot Warning indicator
- Side radar

### FAIL-SAFE

The following systems are canceled:

- Blind Spot Warning (BSW)
- Rear Cross Traffic Alert (RCTA)

### DTC CONFIRMATION PROCEDURE

#### 1. PERFORM DTC CONFIRMATION PROCEDURE

#### CONSULT

1. Start the engine.
2. Select "All DTC Reading" mode.
3. Check if "C1B51" is detected as the current malfunction in "Self Diagnostic Result" mode of "SIDE RADAR RIGHT/LEFT".

#### Is the "C1B51" detected as the current malfunction?

- YES >> Refer to [DAS-146, "Diagnosis Procedure"](#).
- NO-1 >> To check malfunction symptom before repair: Refer to [GI-41, "Intermittent Incident"](#).
- NO-2 >> Confirmation after repair: Inspection End.

### Diagnosis Procedure

INFOID:000000011953178

Regarding Wiring Diagram information, refer to [DAS-130, "Wiring Diagram"](#).

#### 1. CHECK BLIND SPOT WARNING INDICATOR CIRCUIT FOR OPEN (1)

1. Turn ignition switch OFF.
2. Disconnect side radar harness connector and Blind Spot Warning indicator harness connector.
3. Check continuity between side radar harness connector and Blind Spot Warning indicator harness connector.

Side radar		Blind Spot Warning indicator		Continuity
Connector	Terminal	Connector	Terminal	
B77 LH	4	D21 LH	1	Yes
B78 RH		D116 RH		

#### Is the inspection result normal?

- YES >> GO TO 2.
- NO >> Repair or replace harness or connector.

# C1B51 BLIND SPOT WARNING INDICATOR SHORT CIRCUIT

< DTC/CIRCUIT DIAGNOSIS >

[DRIVER ASSISTANCE SYSTEM]

## 2. CHECK BLIND SPOT WARNING INDICATOR CIRCUIT FOR OPEN (2)

Check continuity between Blind Spot Warning indicator harness connector and ground.

Blind Spot Warning indicator		Ground	Continuity
Connector	Terminal		
D21 LH	4		Yes
D116 RH			

Is the inspection result normal?

YES >> GO TO 3.

NO >> Repair or replace harness or connector.

## 3. CHECK SIDE RADAR VOLTAGE OUTPUT

1. Connect side radar harness connector.
2. Check voltage between Blind Spot Warning indicator harness connector and ground.

Blind Spot Warning indicator		Ground	Condition	Voltage (Approx.)
Connector	Terminal			
D21 LH	1		Ignition switch OFF ⇒ ON (Approx. 2 sec.)	6 V
D116 RH				

Is the inspection result normal?

YES >> Replace Blind Spot Warning indicator. Refer to [DAS-178. "Removal and Installation"](#).

NO >> Replace side radar. Refer to [DAS-177. "Removal and Installation"](#).

A  
B  
C  
D  
E  
F  
G  
H  
I  
J  
K  
L  
M  
N  
P

DAS

# C1B52 BLIND SPOT WARNING INDICATOR OPEN CIRCUIT

< DTC/CIRCUIT DIAGNOSIS >

[DRIVER ASSISTANCE SYSTEM]

## C1B52 BLIND SPOT WARNING INDICATOR OPEN CIRCUIT

### DTC Description

INFOID:000000011953179

### DTC DETECTION LOGIC

DTC No.	CONSULT screen terms (Trouble diagnosis content)	DTC detection condition	
C1B52	BSW/BSI IND OPEN CIR (Blind Spot Warning indicator open circuit)	Diagnosis condition	When ignition switch is ON.
		Signal (terminal)	–
		Threshold	Open circuit in Blind Spot Warning indicator circuit is detected
		Diagnosis delay time	–

### POSSIBLE CAUSE

- Blind Spot Warning indicator circuit
- Blind Spot Warning indicator
- Side radar

### FAIL-SAFE

The following systems are canceled:

- Blind Spot Warning (BSW)
- Rear Cross Traffic Alert (RCTA)

### DTC CONFIRMATION PROCEDURE

#### 1. PERFORM DTC CONFIRMATION PROCEDURE

#### CONSULT

1. Start the engine.
2. Select "All DTC Reading" mode.
3. Check if "C1B52" is detected as the current malfunction in "Self Diagnostic Result" mode of "SIDE RADAR RIGHT/LEFT".

#### Is the "C1B52" detected as the current malfunction?

- YES >> Refer to [DAS-148, "Diagnosis Procedure"](#).
- NO-1 >> To check malfunction symptom before repair: Refer to [GI-41, "Intermittent Incident"](#).
- NO-2 >> Confirmation after repair: Inspection End.

### Diagnosis Procedure

INFOID:000000011953180

Regarding Wiring Diagram information, refer to [DAS-130, "Wiring Diagram"](#).

#### 1. CHECK BLIND SPOT WARNING INDICATOR CIRCUIT FOR OPEN (1)

1. Turn ignition switch OFF.
2. Disconnect side radar harness connector and Blind Spot Warning indicator harness connector.
3. Check continuity between side radar harness connector and Blind Spot Warning indicator harness connector.

Side radar		Blind Spot Warning indicator		Continuity
Connector	Terminal	Connector	Terminal	
B77 LH	4	D21 LH	1	Yes
B78 RH		D116 RH		

#### Is the inspection result normal?

- YES >> GO TO 2.
- NO >> Repair or replace harness or connector.



# C1B52 BLIND SPOT WARNING INDICATOR OPEN CIRCUIT

< DTC/CIRCUIT DIAGNOSIS >

[DRIVER ASSISTANCE SYSTEM]

## 2. CHECK BLIND SPOT WARNING INDICATOR CIRCUIT FOR OPEN (2)

Check continuity between Blind Spot Warning indicator harness connector and ground.

Blind Spot Warning indicator		Ground	Continuity
Connector	Terminal		
D21 LH	4		Yes
D116 RH			

Is the inspection result normal?

YES >> GO TO 3.

NO >> Repair or replace harness or connector.

## 3. CHECK SIDE RADAR VOLTAGE OUTPUT

1. Connect side radar harness connector.
2. Check voltage between Blind Spot Warning indicator harness connector and ground.

Blind Spot Warning indicator		Ground	Condition	Voltage (Approx.)
Connector	Terminal			
D21 LH	1		Ignition switch OFF ⇒ ON (Approx. 2 sec.)	6 V
D116 RH				

Is the inspection result normal?

YES >> Replace Blind Spot Warning indicator. Refer to [DAS-178. "Removal and Installation"](#).

NO >> Replace side radar. Refer to [DAS-177. "Removal and Installation"](#).

A  
B  
C  
D  
E  
F  
G  
H  
I  
J  
K  
L  
M  
N  
P

DAS

# C1B55 RADAR BLOCKAGE

< DTC/CIRCUIT DIAGNOSIS >

[DRIVER ASSISTANCE SYSTEM]

## C1B55 RADAR BLOCKAGE

### DTC Description

INFOID:000000011953181

### DTC DETECTION LOGIC

DTC No.	CONSULT screen terms (Trouble diagnosis content)	DTC detection condition	
C1B55	RADAR BLOCKAGE (Radar blockage)	Diagnosis condition	When ignition switch is ON.
		Signal (terminal)	–
		Threshold	Side radar is blocked
		Diagnosis delay time	–

#### NOTE:

DTC "C1B55" may be detected under the following conditions except for possible cause. (Explain to the customer about the difference between the contamination detection function and the indication when the malfunction is detected and tell them, "This is not malfunction")

- The side radar may be blocked by temporary ambient conditions such as splashing water, mist or fog.
- The blocked condition may also be caused by objects such as ice, frost or dirt obstructing the side radar.
- Due to the nature of radar technology, it is possible to get a blockage warning and not actually be blocked. This is rare and is known as a false blockage warning. A false blocked condition either self-clears or clears after an ignition cycle.

#### POSSIBLE CAUSE

Stain or foreign materials are deposited.

#### FAIL-SAFE

The following systems are canceled:

- Blind Spot Warning (BSW)
- Rear Cross Traffic Alert (RCTA)

#### DTC CONFIRMATION PROCEDURE

##### 1. PERFORM DTC CONFIRMATION PROCEDURE

###### ⓑ CONSULT

1. Start the engine.
2. Turn the Blind Spot Warning system ON.
3. Select "All DTC Reading" mode.
4. Check if "C1B55" is detected as the current malfunction in "Self Diagnostic Result" mode of "SIDE RADAR RIGHT/LEFT".

###### Is the DTC "C1B55" detected?

- YES >> Refer to [DAS-150, "Diagnosis Procedure"](#).
- NO-1 >> To check malfunction symptom before repair: Refer to [GI-41, "Intermittent Incident"](#).
- NO-2 >> Confirmation after repair: Inspection End.

#### Diagnosis Procedure

INFOID:000000011953182

##### 1. CHECK THE REAR BUMPER

Check if rear bumper near the side radar is contaminated with foreign materials.

>> GO TO 2.

##### 2. CHECK THE SIDE RADAR

Check if side radar and the side radar outskirts are contaminated with foreign materials.

>> GO TO 3.

##### 3. CHECK THE SIDE RADAR INSTALLATION CONDITION

Check side radar installation condition (installation position, properly tightened or a bent bracket).

# C1B55 RADAR BLOCKAGE

< DTC/CIRCUIT DIAGNOSIS >

[DRIVER ASSISTANCE SYSTEM]

>> GO TO 4.

## 4. INTERVIEW

1. Ask if there is stain or foreign materials.
2. Ask if there is any temporary ambient condition such as splashing water, mist or fog.
3. Ask if there is any object such as ice, frost or dirt obstructing the side radar.

Are any of above conditions seen?

YES >> Explain to the customer about the difference between the blockage detection function and the indication when the malfunction is detected and tell them, "This is not malfunction."

NO >> Inspection End.

A  
B  
C  
D  
E  
F  
G  
H  
I  
J  
K  
L  
M  
N  
P

DAS

U0104 ADAS CAN 1

DTC Description

INFOID:000000011953183

DTC DETECTION LOGIC

DTC No.	CONSULT screen terms (Trouble diagnosis content)	DTC detection condition	
U0104	ADAS CAN CIR1 (ADAS control unit CAN circuit 1)	Diagnosis condition	When ignition switch is ON.
		Signal (terminal)	–
		Threshold	Side radar detected an error of ITS communication signal that was received from ADAS control unit
		Diagnosis delay time	–

POSSIBLE CAUSE

ADAS control unit

FAIL-SAFE

The following systems are canceled:

- Blind Spot Warning (BSW)
- Rear Cross Traffic Alert (RCTA)

DTC CONFIRMATION PROCEDURE

1. CHECK DTC PRIORITY

If DTC “U0104” is displayed with DTC “U1000”, first diagnose the DTC “U1000”.

Is applicable DTC detected?

- YES >> Perform diagnosis of applicable. Refer to [DAS-156, "SIDE RADAR LH : DTC Description"](#) (Side Radar LH) or [DAS-157, "SIDE RADAR RH : DTC Description"](#) (Side Radar RH).
- NO >> GO TO 2.

2. PERFORM DTC CONFIRMATION PROCEDURE

CONSULT

1. Start the engine.
2. Turn the Blind Spot Warning system ON.
3. Select “All DTC Reading” mode.
4. Check if “U0104” is detected as the current malfunction in “Self Diagnostic Result” mode of “SIDE RADAR RIGHT/LEFT”.

Is DTC “U0104” detected?

- YES >> Refer to [DAS-152, "Diagnosis Procedure"](#).
- NO-1 >> To check malfunction symptom before repair: Refer to [GI-41, "Intermittent Incident"](#).
- NO-2 >> Confirmation after repair: Inspection End.

Diagnosis Procedure

INFOID:000000011953184

1. CHECK DTC PRIORITY

If DTC “U0104” is displayed with DTC “U1000”, first diagnose the DTC “U1000”.

Is applicable DTC detected?

- YES >> Perform diagnosis of applicable. Refer to [DAS-156, "SIDE RADAR LH : DTC Description"](#) (Side Radar LH) or [DAS-157, "SIDE RADAR RH : DTC Description"](#) (Side Radar RH).
- NO >> GO TO 2.

2. SELF DIAGNOSTIC RESULT OF ADAS CONTROL UNIT

CONSULT

1. Start the engine.
2. Turn the Blind Spot Warning system ON.
3. Select “Self Diagnostic Result” mode of “ICC/ADAS”.

# U0104 ADAS CAN 1

[DRIVER ASSISTANCE SYSTEM]

< DTC/CIRCUIT DIAGNOSIS >

4. Check DTC.

Is DTC detected?

YES >> Perform diagnosis on the detected DTC and repair or replace the malfunctioning parts. Refer to [DAS-117, "DTC Index"](#).

NO >> Replace side radar LH or side radar RH. Refer to [DAS-177, "Removal and Installation"](#).

A  
B  
C  
D  
E  
F  
G  
H  
I  
J  
K  
L  
M  
N  
P

DAS

U0405 ADAS CAN 2

DTC Description

INFOID:000000011953185

DTC DETECTION LOGIC

DTC No.	CONSULT screen terms (Trouble diagnosis content)	DTC detection condition	
U0405	ADAS CAN CIR2 (ADAS control unit CAN circuit 2)	Diagnosis condition	When ignition switch is ON.
		Signal (terminal)	–
		Threshold	Side radar detected an error of ITS communication signal that was received from ADAS control unit
		Diagnosis delay time	–

POSSIBLE CAUSE

ADAS control unit

FAIL-SAFE

The following systems are canceled:

- Blind Spot Warning (BSW)
- Rear Cross Traffic Alert (RCTA)

DTC CONFIRMATION PROCEDURE

1. CHECK DTC PRIORITY

If DTC “U0405” is displayed with DTC “U1000”, first diagnose the DTC “U1000”.

Is applicable DTC detected?

- YES >> Perform diagnosis of applicable. Refer to [DAS-156, "SIDE RADAR LH : DTC Description"](#) (Side Radar LH) or [DAS-157, "SIDE RADAR RH : DTC Description"](#) (Side Radar RH).
- NO >> GO TO 2.

2. PERFORM DTC CONFIRMATION PROCEDURE

ⓂCONSULT

1. Start the engine.
2. Turn the Blind Spot Warning system ON.
3. Select “All DTC Reading” mode.
4. Check if “U0405” is detected as the current malfunction in “Self Diagnostic Result” mode of “SIDE RADAR RIGHT/LEFT”.

Is DTC “U0405” detected?

- YES >> Refer to [DAS-154, "Diagnosis Procedure"](#).
- NO-1 >> To check malfunction symptom before repair: Refer to [GI-41, "Intermittent Incident"](#).
- NO-2 >> Confirmation after repair: Inspection End.

Diagnosis Procedure

INFOID:000000011953186

1. CHECK DTC PRIORITY

If DTC “U0405” is displayed with DTC “U1000”, first diagnose the DTC “U1000”.

Is applicable DTC detected?

- YES >> Perform diagnosis of applicable. Refer to [DAS-156, "SIDE RADAR LH : DTC Description"](#) (Side Radar LH) or [DAS-157, "SIDE RADAR RH : DTC Description"](#) (Side Radar RH).
- NO >> GO TO 2.

2. SELF DIAGNOSTIC RESULT OF ADAS CONTROL UNIT

ⓂCONSULT

1. Start the engine.
2. Turn the Blind Spot Warning system ON.
3. Select “Self Diagnostic Result” mode of “ICC/ADAS”.

## U0405 ADAS CAN 2

< DTC/CIRCUIT DIAGNOSIS >

[DRIVER ASSISTANCE SYSTEM]

4. Check DTC.

Is DTC detected?

- YES >> Perform diagnosis on the detected DTC and repair or replace the malfunctioning parts. Refer to [DAS-117, "DTC Index"](#).
- NO >> Replace side radar LH or side radar RH. Refer to [DAS-177, "Removal and Installation"](#).

A  
B  
C  
D  
E  
F  
G  
H  
I  
J  
K  
L  
M  
N  
P

DAS

# U1000 CAN COMM CIRCUIT

< DTC/CIRCUIT DIAGNOSIS >

[DRIVER ASSISTANCE SYSTEM]

## U1000 CAN COMM CIRCUIT

### SIDE RADAR LH

#### SIDE RADAR LH : Description

INFOID:0000000011953187

#### CAN COMMUNICATION

CAN (Controller Area Network) is a serial communication line for real-time applications. It is an on-vehicle multiplex communication line with high data communication speed and excellent error detection ability. Modern vehicles are equipped with many electronic control units, and each control unit shares information and links with other control units during operation (not independent). In CAN communication, control units are connected with 2 communication lines (CAN-H, CAN-L), allowing a high rate of information transmission with less wiring. Each control unit transmits/receives data but selectively reads the required data only.

For CAN communication signal chart. Refer to [LAN-32. "CAN COMMUNICATION SYSTEM : CAN Communication Signal Chart"](#).

#### ITS COMMUNICATION

- ITS communication is a multiplex communication system. This enables the system to transmit and receive large quantities of data at high speed by connecting plural units with 2 communication lines.
- ITS communication lines adopt twisted-pair line style (two lines twisted) for noise immunity.

#### SIDE RADAR LH : DTC Description

INFOID:0000000011953188

#### DTC DETECTION LOGIC

DTC No.	CONSULT screen terms (Trouble diagnosis content)	DTC detection condition	
U1000	CAN COMM CIRCUIT (CAN communication circuit)	Diagnosis condition	When ignition switch is ON.
		Signal (terminal)	–
		Threshold	If side radar LH is not transmitting or receiving ITS communication signal
		Diagnosis delay time	2 seconds or more

#### POSSIBLE CAUSE

ITS communication system

#### FAIL-SAFE

The following systems are canceled:

- Blind Spot Warning (BSW)
- Rear Cross Traffic Alert (RCTA)

#### DTC CONFIRMATION PROCEDURE

##### 1. PERFORM DTC CONFIRMATION PROCEDURE

##### CONSULT

1. Start the engine.
2. Turn the Blind Spot Warning system ON.
3. Select "All DTC Reading" mode.
4. Check if "U1000" is detected as the current malfunction in "Self Diagnostic Result" mode of "SIDE RADAR LEFT".

##### Is "U1000" detected?

- YES >> Refer to [DAS-156. "SIDE RADAR LH : Diagnosis Procedure"](#).
- NO-1 >> To check malfunction symptom before repair: Refer to [GI-41. "Intermittent Incident"](#).
- NO-2 >> Confirmation after repair: Inspection End.

#### SIDE RADAR LH : Diagnosis Procedure

INFOID:0000000011953189

##### 1. SELF DIAGNOSTIC RESULT

##### CONSULT



# U1000 CAN COMM CIRCUIT

[DRIVER ASSISTANCE SYSTEM]

< DTC/CIRCUIT DIAGNOSIS >

1. Start the engine.
2. Turn the Blind Spot Warning system ON, and then wait for 30 seconds or more.
3. Perform "ALL DTC Reading" mode.
4. Check if "U1000" is detected as the current malfunction in "Self Diagnostic Result" mode of "SIDE RADAR LEFT".

Is "U1000" detected?

YES >> Refer to [LAN-17, "Trouble Diagnosis Flow Chart"](#).

NO-1 >> To check malfunction symptom before repair: Refer to [GI-41, "Intermittent Incident"](#).

NO-2 >> Confirmation after repair: Inspection End.

## SIDE RADAR RH

### SIDE RADAR RH : Description

INFOID:000000011953190

### CAN COMMUNICATION

CAN (Controller Area Network) is a serial communication line for real-time applications. It is an on-vehicle multiplex communication line with high data communication speed and excellent error detection ability. Modern vehicles are equipped with many electronic control units, and each control unit shares information and links with other control units during operation (not independent). In CAN communication, control units are connected with 2 communication lines (CAN-H, CAN-L), allowing a high rate of information transmission with less wiring. Each control unit transmits/receives data but selectively reads the required data only.

For CAN communication signal chart. Refer to [LAN-32, "CAN COMMUNICATION SYSTEM : CAN Communication Signal Chart"](#).

### ITS COMMUNICATION

- ITS communication is a multiplex communication system. This enables the system to transmit and receive large quantities of data at high speed by connecting plural units with 2 communication lines.
- ITS communication lines adopt twisted-pair line style (two lines twisted) for noise immunity.

### SIDE RADAR RH : DTC Description

INFOID:000000011953191

### DTC DETECTION LOGIC

DTC No.	CONSULT screen terms (Trouble diagnosis content)	DTC detection condition	
U1000	CAN COMM CIRCUIT (CAN communication circuit)	Diagnosis condition	When ignition switch is ON.
		Signal (terminal)	-
		Threshold	If side radar RH is not transmitting or receiving ITS communication signal
		Diagnosis delay time	2 seconds or more

### POSSIBLE CAUSE

ITS communication system

### FAIL-SAFE

The following systems are canceled:

- Blind Spot Warning (BSW)
- Rear Cross Traffic Alert (RCTA)

### DTC CONFIRMATION PROCEDURE

#### 1. PERFORM DTC CONFIRMATION PROCEDURE

#### CONSULT

1. Start the engine.
2. Turn the Blind Spot Warning system ON.
3. Select "All DTC Reading" mode.
4. Check if "U1000" is detected as the current malfunction in "Self Diagnostic Result" mode of "SIDE RADAR RIGHT".

Is "U1000" detected?

YES >> Refer to [DAS-158, "SIDE RADAR RH : Diagnosis Procedure"](#).

# U1000 CAN COMM CIRCUIT

[DRIVER ASSISTANCE SYSTEM]

< DTC/CIRCUIT DIAGNOSIS >

NO-1 >> To check malfunction symptom before repair: Refer to [GI-41, "Intermittent Incident"](#).

NO-2 >> Confirmation after repair: Inspection End.

## SIDE RADAR RH : Diagnosis Procedure

INFOID:0000000011953192

### 1. SELF DIAGNOSTIC RESULT

#### CONSULT

1. Start the engine.
2. Turn the Blind Spot Warning system ON, and then wait for 30 seconds or more.
3. Select "ALL DTC Reading" mode.
4. Check if "U1000" is detected as the current malfunction in "Self Diagnostic Result" mode of "SIDE RADAR RIGHT".

#### Is "U1000" detected?

YES >> Refer to [LAN-17, "Trouble Diagnosis Flow Chart"](#).

NO-1 >> To check malfunction symptom before repair: Refer to [GI-41, "Intermittent Incident"](#).

NO-2 >> Confirmation after repair: Inspection End.

# U1010 CONTROL UNIT (CAN)

< DTC/CIRCUIT DIAGNOSIS >

[DRIVER ASSISTANCE SYSTEM]

## U1010 CONTROL UNIT (CAN)

### SIDE RADAR LH

#### SIDE RADAR LH : Description

INFOID:0000000011953193

CAN controller controls the communication of ITS communication signal and the error detection.

#### SIDE RADAR LH : DTC Description

INFOID:0000000011953194

#### DTC DETECTION LOGIC

DTC No.	CONSULT screen terms (Trouble diagnosis content)	DTC detection condition	
U1010	CONTROL UNIT (CAN) [Control unit (CAN)]	Diagnosis condition	When ignition switch is ON.
		Signal (terminal)	-
		Threshold	If side radar LH detects malfunction by CAN controller initial diagnosis
		Diagnosis delay time	-

#### POSSIBLE CAUSE

Side radar LH

#### FAIL-SAFE

The following systems are canceled:

- Blind Spot Warning (BSW)
- Rear Cross Traffic Alert (RCTA)

#### DTC CONFIRMATION PROCEDURE

##### 1. PERFORM DTC CONFIRMATION PROCEDURE

###### ⓂCONSULT

1. Start the engine.
2. Turn the Blind Spot Warning system ON.
3. Select "All DTC Reading" mode.
4. Check if "U1010" is detected as the current malfunction in "Self Diagnostic Result" mode of "SIDE RADAR LEFT".

###### Is "U1010" detected?

- YES >> Refer to [DAS-159, "SIDE RADAR LH : Diagnosis Procedure"](#).
- NO-1 >> To check malfunction symptom before repair: Refer to [GI-41, "Intermittent Incident"](#).
- NO-2 >> Confirmation after repair: Inspection End.

#### SIDE RADAR LH : Diagnosis Procedure

INFOID:0000000011953195

##### 1. SELF DIAGNOSTIC RESULT

###### ⓂCONSULT

1. Start the engine.
2. Turn the Blind Spot Warning system ON.
3. Select "ALL DTC Reading" mode.
4. Check if "U1010" is detected as the current malfunction in "Self Diagnostic Result" mode of "SIDE RADAR LEFT".

###### Is "U1010" detected?

- YES >> Replace the side radar LH. Refer to [DAS-177, "Removal and Installation"](#).
- NO >> Inspection End.

#### SIDE RADAR RH

#### SIDE RADAR RH : Description

INFOID:0000000011953196

CAN controller controls the communication of ITS communication signal and the error detection.

A  
B  
C  
D  
E  
F  
G  
H  
I  
J  
K  
L  
M  
N  
P

DAS

# U1010 CONTROL UNIT (CAN)

< DTC/CIRCUIT DIAGNOSIS >

[DRIVER ASSISTANCE SYSTEM]

## SIDE RADAR RH : DTC Description

INFOID:000000011953197

### DTC DETECTION LOGIC

DTC No.	CONSULT screen terms (Trouble diagnosis content)	DTC detection condition	
U1010	CONTROL UNIT (CAN) [Control unit (CAN)]	Diagnosis condition	When ignition switch is ON.
		Signal (terminal)	–
		Threshold	If side radar RH detects malfunction by CAN controller initial diagnosis
		Diagnosis delay time	–

### POSSIBLE CAUSE

Side radar RH

### FAIL-SAFE

The following systems are canceled:

- Blind Spot Warning (BSW)
- Rear Cross Traffic Alert (RCTA)

### DTC CONFIRMATION PROCEDURE

#### 1.PERFORM DTC CONFIRMATION PROCEDURE

##### CONSULT

1. Start the engine.
2. Turn the Blind Spot Warning system ON.
3. Select "All DTC Reading" mode.
4. Check if "U1010" is detected as the current malfunction in "Self Diagnostic Result" mode of "SIDE RADAR RIGHT".

##### Is "U1010" detected?

- YES >> Refer to [DAS-160. "SIDE RADAR RH : Diagnosis Procedure"](#).  
NO-1 >> To check malfunction symptom before repair: Refer to [GI-41. "Intermittent Incident"](#).  
NO-2 >> Confirmation after repair: Inspection End.

## SIDE RADAR RH : Diagnosis Procedure

INFOID:000000011953198

#### 1.SELF DIAGNOSTIC RESULT

##### CONSULT

1. Start the engine.
2. Turn the Blind Spot Warning system ON.
3. Select "ALL DTC Reading" mode.
4. Check if "U1010" is detected as the current malfunction in "Self Diagnostic Result" mode of "SIDE RADAR RIGHT".

##### Is "U1010" detected?

- YES >> Replace the side radar RH. Refer to [DAS-177. "Removal and Installation"](#).  
NO >> Inspection End.

# POWER SUPPLY AND GROUND CIRCUIT

< DTC/CIRCUIT DIAGNOSIS >

[DRIVER ASSISTANCE SYSTEM]

## POWER SUPPLY AND GROUND CIRCUIT

### SIDE RADAR LH

#### SIDE RADAR LH : Diagnosis Procedure

INFOID:0000000011953199

Regarding Wiring Diagram information, refer to [DAS-130. "Wiring Diagram"](#).

### 1.CHECK FUSES

Check that the following fuse is not blown:

Signal name	Fuse No.
Ignition power supply	30 (10 A)

Is the fuse blown?

- YES >> Replace the blown fuse after repairing the affected circuit.
- NO >> GO TO 2.

### 2.CHECK POWER SUPPLY CIRCUIT

1. Turn ignition switch OFF.
2. Disconnect the side radar LH connector.
3. Check voltage between side radar LH harness connector and ground.

Terminal		Condition	Voltage (Approx.)
(+)	(-)		
Side radar LH		Ground	Ignition switch
Connector	Terminal		
B77	5		
		OFF	0 V
		ON	Battery voltage

Is the inspection result normal?

- YES >> GO TO 3.
- NO >> Repair the side radar LH power supply circuit.

### 3.CHECK GROUND CIRCUIT

Check continuity between side radar LH harness connector and ground.

Side radar LH		Ground	Continuity
Connector	Terminal		
B77	8		Yes

Is the inspection result normal?

- YES >> Inspection End.
- NO >> Repair the side radar LH ground circuit.

### SIDE RADAR RH

#### SIDE RADAR RH : Diagnosis Procedure

INFOID:0000000011953200

Regarding Wiring Diagram information, refer to [DAS-130. "Wiring Diagram"](#).

### 1.CHECK FUSES

Check that the following fuse is not blown:

A  
B  
C  
D  
E  
F  
G  
H  
I  
J  
K  
L  
M  
N  
P

DAS

# POWER SUPPLY AND GROUND CIRCUIT

< DTC/CIRCUIT DIAGNOSIS >

[DRIVER ASSISTANCE SYSTEM]

Signal name	Fuse No.
Ignition power supply	30 (10 A)

Is the fuse blown?

YES >> Replace the blown fuse after repairing the affected circuit.

NO >> GO TO 2.

## 2.CHECK POWER SUPPLY CIRCUIT

1. Turn ignition switch OFF.
2. Disconnect the side radar RH connector.
3. Check voltage between side radar RH harness connector and ground.

Terminal		Condition	Voltage (Approx.)
(+)	(-)		
Side radar RH		Ground	Ignition switch
Connector	Terminal		
B78	5		
		OFF	0 V
		ON	Battery voltage

Is the inspection result normal?

YES >> GO TO 3.

NO >> Repair the side radar RH power supply circuit.

## 3.CHECK GROUND CIRCUIT

Check continuity between side radar RH harness connector and ground.

Side radar RH		Ground	Continuity
Connector	Terminal		
B78	3		Yes
	8		

Is the inspection result normal?

YES >> Inspection End.

NO >> Repair the side radar RH ground circuit.

# RIGHT/LEFT SWITCHING SIGNAL CIRCUIT

< DTC/CIRCUIT DIAGNOSIS >

[DRIVER ASSISTANCE SYSTEM]

## RIGHT/LEFT SWITCHING SIGNAL CIRCUIT

### Diagnosis Procedure

INFOID:0000000011953201

Regarding Wiring Diagram information, refer to [DAS-130. "Wiring Diagram"](#).

#### 1. CHECK CONNECTOR

1. Turn the ignition switch OFF.
2. Check the terminals and connectors of the side radar RH for damage, bend and short (unit side and connector side).

Is the inspection result normal?

YES >> GO TO 2.

NO >> Repair the terminal or connector.

#### 2. CHECK CONTINUITY OF RIGHT/LEFT SWITCHING SIGNAL CIRCUIT

1. Disconnect side radar RH connector.
2. Check continuity between side radar RH harness connector and ground.

Side radar RH		Ground	Continuity
Connector	Terminal		
B78	3		Yes

Is the inspection result normal?

YES >> Inspection End.

NO >> Repair harness or connector.

A  
B  
C  
D  
E  
F  
G  
H  
I  
J  
K  
L  
M  
N  
P

DAS

# DRIVER ASSISTANCE SYSTEM SYMPTOMS

< SYMPTOM DIAGNOSIS >

[DRIVER ASSISTANCE SYSTEM]

## SYMPTOM DIAGNOSIS

### DRIVER ASSISTANCE SYSTEM SYMPTOMS

#### Symptom Table

INFOID:0000000011953204

Symptom	Confirmation item	Inspection item/Reference page	
PFCW/FEB/BSW/RCTA indicators do not illuminate.	All of driver assistance indicators do not illuminate.	System cannot be turned ON/OFF using the integral switch. Refer to <a href="#">DAS-165, "Description"</a> .	
	Other information display is not illuminated.	Combination meter Refer to <a href="#">MWI-18, "On Board Diagnosis Function"</a> .	
FEB/PFCW/BSW/RCTA warning display does not illuminate (Buzzer is functioning normally)	Information display is functioning normally.	ADAS control unit Refer to <a href="#">DAS-25, "DTC Index"</a> .	
	Information display is not functioning normally.	Perform on board diagnosis of combination meter. Refer to <a href="#">MWI-18, "On Board Diagnosis Function"</a> .	
FEB/PFCW warning buzzer is not sounding. (Warning display is functioning normally)	FEB/PFCW warning buzzer does not sound.	Chime does not sound. Refer to <a href="#">DAS-166, "Description"</a> .	
BSW/RCTA warning buzzer is not sounding. (Warning display is functioning normally)	BSW/RCTA warning buzzer does not sound.	Chime does not sound. Refer to <a href="#">DAS-166, "Description"</a> .	
PFCW/FEB is not activated.	PFCW and FEB are not activated.	Frequently cannot detect the vehicle ahead/Detection zone is short.	Frequently cannot detect the vehicle ahead/Detection zone is short. Refer to <a href="#">DAS-167, "Description"</a> .
		System misidentifies a vehicle even though there is no vehicle ahead.	Perform radar alignment. Refer to <a href="#">CCS-59, "Description"</a> .
		System misidentifies a vehicle in the next lane.	
		System does not detect the vehicle ahead at all.	The system does not detect the vehicle ahead at all. Refer to <a href="#">DAS-169, "Description"</a> .



# SYSTEM SETTINGS CANNOT BE TURNED ON/OFF ON THE INTEGRAL SWITCH

< SYMPTOM DIAGNOSIS >

[DRIVER ASSISTANCE SYSTEM]

## SYSTEM SETTINGS CANNOT BE TURNED ON/OFF ON THE INTEGRAL SWITCH

### Description

INFOID:0000000011953205

System setting is not selectable in the combination meter information display.

### Diagnosis Procedure

INFOID:0000000011953206

#### 1.CHECK DRIVER ASSISTANCE SYSTEM SETTING

1. Turn ignition switch ON.
2. Check that the driver assistance system setting can be turned ON/OFF with the integral switch in the combination meter information display using the steering switches.

Is the inspection result normal?

- YES >> Inspection End.
- NO >> GO TO 2.

#### 2.CHECK STEERING SWITCH CIRCUIT

Check the steering switches. Refer to [MWI-57, "Diagnosis Procedure"](#).

Is the inspection result normal?

- YES >> GO TO 3.
- NO >> Repair or replace harness or connector.

#### 3.CHECK STEERING SWITCH RESISTANCE

Check the resistance of the steering switches . Refer to [MWI-57, "Component Inspection"](#).

Is the inspection result normal?

- YES >> Replace combination meter. Refer to [MWI-68, "Removal and Installation"](#).
- NO >> Replace steering switches. Refer to [AV-184, "Removal and Installation"](#).

A  
B  
C  
D  
E  
F  
G  
H  
I  
J  
K  
L  
M  
N  
P

DAS

# CHIME DOES NOT SOUND

< SYMPTOM DIAGNOSIS >

[DRIVER ASSISTANCE SYSTEM]

## CHIME DOES NOT SOUND

### Description

INFOID:000000011953207

The warning chime may not sound in some cases when there is a short distance between vehicles. Some examples are:

- When the vehicles are traveling at the same speed and the distance between vehicles is not changing.
- When the vehicle ahead is traveling faster and the distance between vehicles is increasing.
- When a vehicle cuts in near own vehicle.
- The warning chime will not sound when own vehicle approaches vehicles that are parked or moving slowly.
- The warning chime does not sound when the system does not detect any vehicle ahead. (Diagnose the conditions under which the system is detecting the vehicle ahead and when the system is malfunctioning. If there is any malfunction in detecting the vehicle ahead, check the system following the [DAS-167, "Description".](#))

### Diagnosis Procedure

INFOID:000000011953208

#### 1.PERFORM ACTIVE TEST

##### ⓐCONSULT

1. Select "METER BUZZER" in "Active Test" mode of "ICC/ADAS".
2. Check that the function operates normally.

Is the inspection result normal?

- YES >> Inspection End.  
NO >> GO TO 2.

#### 2.PERFORM THE SELF DIAGNOSTIC RESULT

##### ⓐCONSULT

1. Perform "All DTC Reading" mode.
2. Check if the "U1000" is detected in "Self Diagnostic Result" mode of "ICC/ADAS".

Is "U1000" detected?

- YES >> GO TO 3.  
NO >> GO TO 4.

#### 3.CAN COMMUNICATION INSPECTION

Check the CAN communication and repair or replace malfunctioning parts. Refer to [DAS-65, "DTC Description"](#).

>> Inspection End.

#### 4.CHECK METER BUZZER OPERATION

Check meter buzzer. Refer to [WCS-27, "Component Function Check"](#).

Is the inspection result normal?

- YES >> Replace the ADAS control unit. Refer to [DAS-80, "Removal and Installation"](#).  
NO >> Replace the combination meter. Refer to [MWI-68, "Removal and Installation"](#).

# FREQUENTLY CANNOT DETECT THE VEHICLE AHEAD / DETECTION ZONE IS SHORT

< SYMPTOM DIAGNOSIS >

[DRIVER ASSISTANCE SYSTEM]

## FREQUENTLY CANNOT DETECT THE VEHICLE AHEAD / DETECTION ZONE IS SHORT

### Description

INFOID:0000000011953209

Symptom check: Detection function may become unstable under the following conditions:

- When the vehicle is driving on a curve such as an S-curve where the curvature changes.
- When the vehicle is driving on an up-and-down road or passing the peak or foot of a slope or passing the break of the inclination of a hill.

### Diagnosis Procedure

INFOID:0000000011953210

#### 1.VISUAL CHECK (1)

Check ICC sensor for contamination and foreign materials.

Does contamination or foreign materials exist?

YES >> GO TO 2.

NO >> GO TO 3.

#### 2.WIPE OUT DIRT AND FOREIGN MATERIAL

Clean the contamination and foreign material from the ICC sensor.

>> GO TO 7.

#### 3.VISUAL CHECK (2)

Check ICC sensor and ICC sensor bracket for damage or looseness.

Does damage or looseness exist?

YES >> Repair or replace affected components. Refer to [CCS-136, "Removal and Installation"](#).

NO >> GO TO 4.

#### 4.PERFORM RADAR ALIGNMENT

1. Perform radar alignment. Refer to [CCS-59, "Description"](#).

2. Perform action test. Refer to [CCS-66, "Description"](#).

3. Check that the vehicle ahead detection performance improves.

Does it improve?

YES >> Inspection End.

NO >> GO TO 5.

#### 5.REPLACE ICC SENSOR

1. Replace the ICC sensor. Refer to [CCS-136, "Removal and Installation"](#).

2. Perform radar alignment. Refer to [CCS-59, "Description"](#).

3. Perform action test. Refer to [CCS-66, "Description"](#).

4. Check that the vehicle ahead detection performance improves.

Does it improve?

YES >> Inspection End.

NO >> GO TO 6.

#### 6.REPLACE ADAS CONTROL UNIT

Replace the ADAS control unit. Refer to [DAS-80, "Removal and Installation"](#).

>> GO TO 7.

#### 7.CHECK ICC SYSTEM

1. Erase "Self Diagnostic Result", and then perform "All DTC Reading" again after performing the action test. (Refer to [CCS-66, "Description"](#) for action test.)

2. Check that the ICC system is normal.

A  
B  
C  
D  
E  
F  
G  
H  
I  
J  
K  
L  
M  
N

DAS

P

**FREQUENTLY CANNOT DETECT THE VEHICLE AHEAD / DETECTION ZONE IS SHORT**

< SYMPTOM DIAGNOSIS >

[DRIVER ASSISTANCE SYSTEM]

---

>> Inspection End.

# THE SYSTEM DOES NOT DETECT THE VEHICLE AHEAD AT ALL

< SYMPTOM DIAGNOSIS >

[DRIVER ASSISTANCE SYSTEM]

## THE SYSTEM DOES NOT DETECT THE VEHICLE AHEAD AT ALL

### Description

INFOID:0000000011953211

When PFCW/FEB system is active, the PFCW/FEB system does not perform any control even though there is a vehicle ahead.

### Diagnosis Procedure

INFOID:0000000011953212

#### 1. CHECK INFORMATION DISPLAY

1. Start the "Self Diagnosis" of combination meter. Refer to [MWI-18, "On Board Diagnosis Function"](#).
2. Check that the segment of information display is displayed normally.

Is the inspection result normal?

YES >> GO TO 2.

NO >> Replace the combination meter. Refer to [MWI-68, "Removal and Installation"](#).

#### 2. VISUAL CHECK (1)

Check ICC sensor for contamination and foreign materials.

Does contamination or foreign materials exist?

YES >> GO TO 3.

NO >> GO TO 4.

#### 3. WIPE OUT DIRT AND FOREIGN MATERIAL

Clean the contamination and foreign material from the ICC sensor.

>> Inspection End.

#### 4. VISUAL CHECK (2)

Check ICC sensor and ICC sensor bracket for damage or looseness.

Does damage or looseness exist?

YES >> Repair or replace affected components. Refer to [CCS-136, "Removal and Installation"](#).

NO >> GO TO 5.

#### 5. PERFORM RADAR ALIGNMENT

1. Perform radar alignment. Refer to [CCS-59, "Description"](#).
2. Perform action test. Refer to [CCS-66, "Description"](#).
3. Check that the vehicle ahead detection performance improves.

Does it improve?

YES >> Inspection End.

NO >> GO TO 6.

#### 6. REPLACE ICC SENSOR

1. Replace the ICC sensor. Refer to [CCS-136, "Removal and Installation"](#).
2. Perform radar alignment. Refer to [CCS-59, "Description"](#).
3. Perform action test. Refer to [CCS-66, "Description"](#).
4. Check that the vehicle ahead detection performance improves.

Does it improve?

YES >> Inspection End.

NO >> GO TO 7.

#### 7. REPLACE ADAS CONTROL UNIT

Replace the ADAS control unit. Refer to [DAS-80, "Removal and Installation"](#).

>> Inspection End.

A  
B  
C  
D  
E  
F  
G  
H  
I  
J  
K  
L  
M  
N  
P

DAS

**NORMAL OPERATING CONDITION****Description**

INFOID:000000011953213

**PRECAUTIONS FOR PREDICTIVE FORWARD COLLISION WARNING (PFCW)**

- The Predictive Forward Collision Warning system is designed to warn the driver before a collision, but will not avoid a collision. It is the driver's responsibility to stay alert, drive safely and be in control of the vehicle at all times.
- The radar sensor does not detect the following objects:
  - Pedestrians, animals, or obstacles in the roadway.
  - Oncoming vehicles.
  - Crossing vehicles.
- The Predictive Forward Collision Warning system does not function when a vehicle ahead is a narrow vehicle, such as a motorcycle.
- The radar sensor may not detect a second vehicle ahead in the following conditions:
  - Snow or heavy rain.
  - Dirt, ice, snow or other material covering the radar sensor.
  - Interference by other radar sources.
  - Snow or road spray from traveling vehicles is splashed.
  - Driving in a tunnel.
- The radar sensor may not detect a second vehicle when the vehicle ahead is being towed.
- When the distance to the vehicle ahead is too close, the beam of the radar sensor is obstructed.
- The radar sensor may not detect a second vehicle when driving on a steep downhill slope or on roads with sharp curves.
- Excessive noise will interfere with the warning tone sound, and it may not be heard.

**PRECAUTIONS FOR BLIND SPOT WARNING**

- The Blind Spot Warning system is not a replacement for proper driving procedure and is not designed to prevent contact with vehicles or objects. When changing lanes, always use the side and rear mirrors and turn and look in the direction the vehicle will move to ensure it is safe to change lanes. Never rely solely on the Blind Spot Warning system.
- The Blind Spot Warning system may not provide the warning or the control for vehicles that pass through the detection zone quickly.
- Excessive noise (for example, audio system volume or open vehicle window) will interfere with the chime sound, and it may not be heard.
- The side radar may not be able to detect and activate Blind Spot Warning when certain objects are present such as:
  - Pedestrians, bicycles, animals.
  - Several types of vehicles such as motorcycles.
  - Oncoming vehicles.
  - Vehicles remaining in the detection zone when driver accelerates from a stop.
  - A vehicle merging into an adjacent lane at a speed approximately the same as own vehicle.
  - A vehicle approaching rapidly from behind.
  - A vehicle which own vehicle overtakes rapidly.
- Severe weather or road spray conditions may reduce the ability of the radar to detect other vehicles.
- The side radar detection zone is designed based on a standard lane width. When driving in a wider lane, the side radar may not detect vehicles in an adjacent lane. When driving in a narrow lane, the side radar may detect vehicles driving two lanes away.
- The side radar is designed to ignore most stationary objects; however, objects such as guardrails, walls, foliage and parked vehicles may occasionally be detected. This is a normal operating condition.

**PRECAUTIONS FOR REAR CROSS TRAFFIC ALERT (RCTA)**

- Always check surroundings and turn to check what is behind you before backing up. The radar sensors detect approaching (moving) vehicles. The radar sensors cannot detect every object such as:
  - Pedestrians, bicycles, motorcycles, animals or child operated toy vehicles.
  - A vehicle that is passing at speeds greater than approximately 19 mph (30 km/h).
  - A vehicle that is passing at speeds less than approximately 5 mph (8 km/h).
- The radar sensors may not detect approaching vehicles in certain situations:
  - When the vehicle that is parked next to you obstructs the beam of the radar sensor.
  - When the vehicle is parked in an angled parking space.
  - When the vehicle is parked on an incline.

## NORMAL OPERATING CONDITION

< SYMPTOM DIAGNOSIS >

[DRIVER ASSISTANCE SYSTEM]

- When an approaching vehicle turns into your vehicle's parking lot isle.
- When the angle formed by your vehicle is too small.
- The following conditions may reduce the ability of the radar to detect other vehicles:
  - Severe weather
  - Road spray
  - Ice build-up on the vehicle
  - Frost on the vehicle
  - Dirt build-up on the vehicle
- Do not attach stickers (including transparent material), install accessories or apply additional paint near the radar sensors. These conditions may reduce the ability of the radar to detect other vehicles.
- Do not use RCTA system when towing a trailer.
- Excessive noise (e.g., audio system volume or open vehicle window) will interfere with the chime sound, and it may not be heard.

A

B

C

D

E

F

G

H

I

J

K

L

M

N

DAS

P

# ICC SENSOR

< REMOVAL AND INSTALLATION >

[DRIVER ASSISTANCE SYSTEM]

## REMOVAL AND INSTALLATION

### ICC SENSOR

#### Exploded View

INFOID:000000013094009

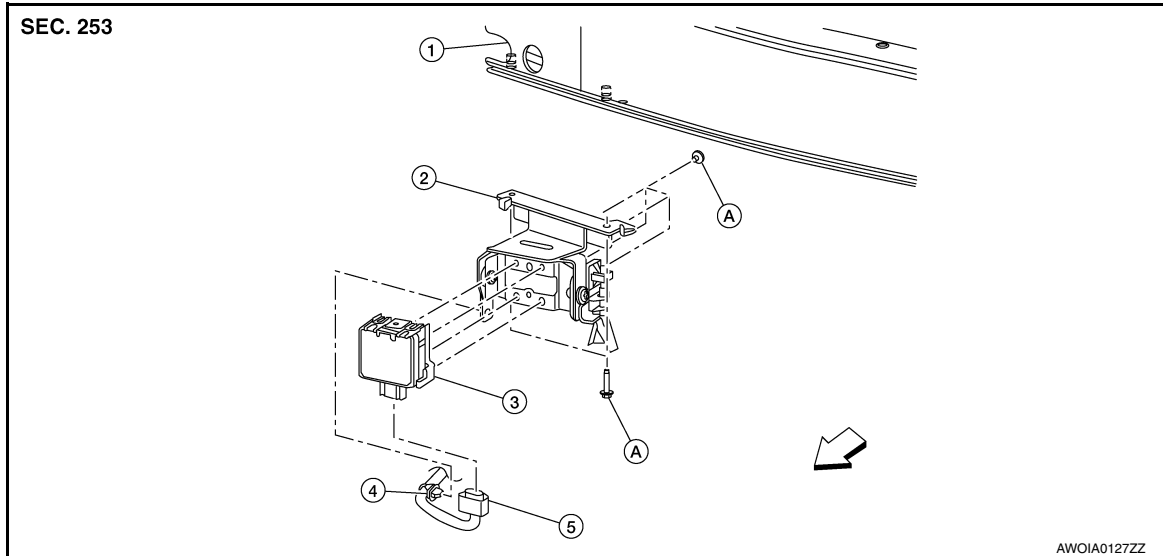

- |                               |                                 |                          |
|-------------------------------|---------------------------------|--------------------------|
| 1. Front bumper reinforcement | 2. ICC sensor bracket           | 3. ICC sensor            |
| 4. Clip                       | 5. ICC sensor harness connector | A. Refer to INSTALLATION |

⇐ Front

### Removal and Installation

INFOID:000000013094010

#### REMOVAL

1. Remove front bumper fascia. Refer to [EXT-16, "Exploded View"](#).
2. Disconnect harness connector from ICC sensor.
3. Remove bolts and remove ICC sensor bracket from front bumper reinforcement.
4. Remove bolts and remove ICC sensor from ICC sensor bracket.

#### INSTALLATION

1. Install ICC sensor to ICC sensor bracket.
2. Install ICC sensor bolts finger tight, then tighten in sequence shown.

**ICC sensor bolts : 3.8 N·m (0.39 kg·m, 34 in-lb)**

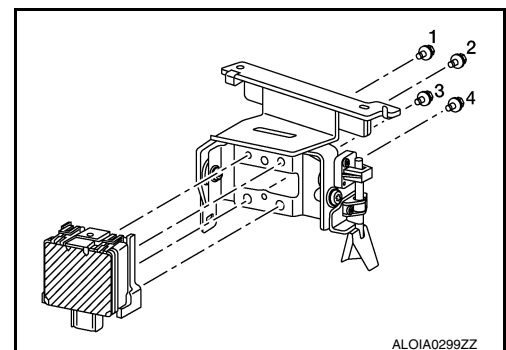

3. Install ICC sensor bracket to front bumper reinforcement.



## ICC SENSOR

### < REMOVAL AND INSTALLATION >

### [DRIVER ASSISTANCE SYSTEM]

4. Install ICC sensor bracket bolts finger tight, then tighten in sequence shown.

**ICC sensor bracket bolts : 10.0 N·m (1.0 kg-m, 7 ft-lb)**

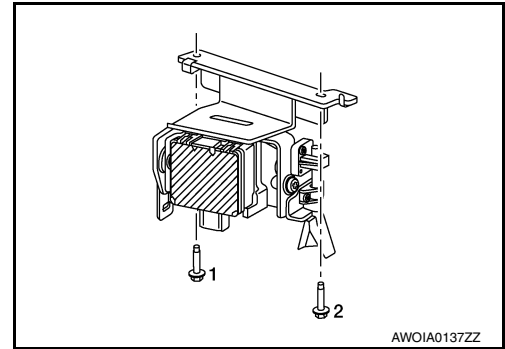

5. Install remaining components in the reverse order of removal.

#### **CAUTION:**

- Always perform ICC sensor alignment and check operation after removal, installation or replacement of ICC sensor. Refer to [CCS-56, "Work Procedure"](#).
- Do not touch ICC sensor face.
- Do not drop or shock ICC sensor.
- Make sure ICC sensor harness is installed without any twists.

A  
B  
C  
D  
E  
F  
G  
H  
I  
J  
K  
L  
M  
N  
P

DAS

# ICC STEERING SWITCH

< REMOVAL AND INSTALLATION >

[DRIVER ASSISTANCE SYSTEM]

## ICC STEERING SWITCH

Exploded View

INFOID:000000013094011

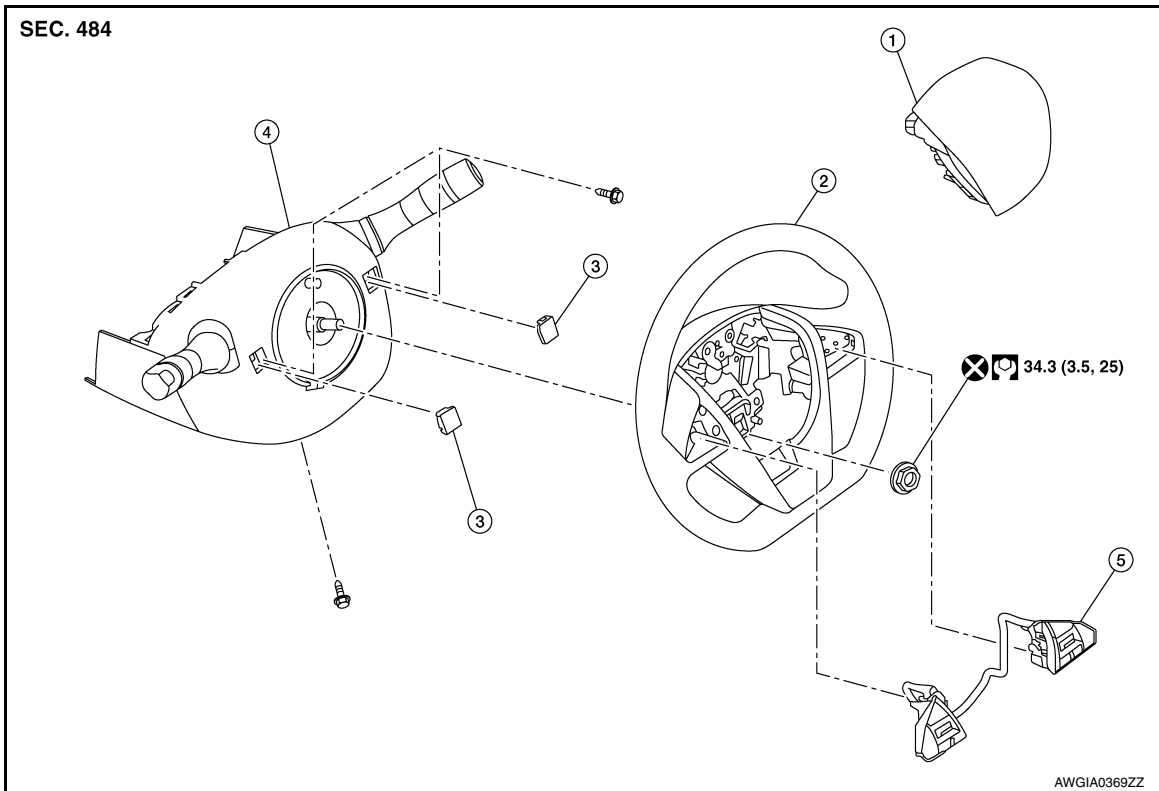

- 1. Driver air bag module
- 2. Steering wheel
- 3. Cover
- 4. Steering column cover
- 5. Steering wheel switches

## Removal and Installation

INFOID:000000013094012

### REMOVAL

#### NOTE:

The steering switches are serviced as an assembly.

1. Remove steering wheel. Refer to [ST-30, "Removal and Installation"](#).
2. Remove screws (A).
3. Release pawls using suitable tool, then remove steering wheel rear finisher (1) from steering wheel (2).

 : Pawl

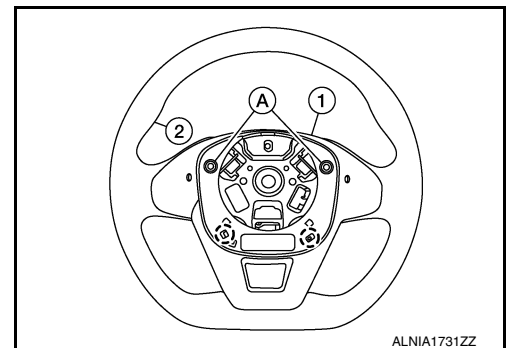

# ICC STEERING SWITCH

## < REMOVAL AND INSTALLATION >

## [DRIVER ASSISTANCE SYSTEM]

4. Remove screws (A)
5. Release pawls using suitable tool, then remove steering wheel front finisher (2) from steering wheel (1).

 : Pawl

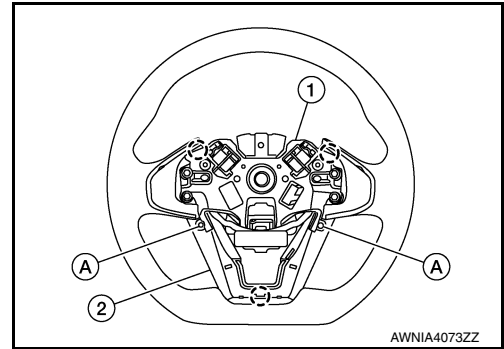

6. Remove screws (A) and remove steering switches from steering wheel (1).

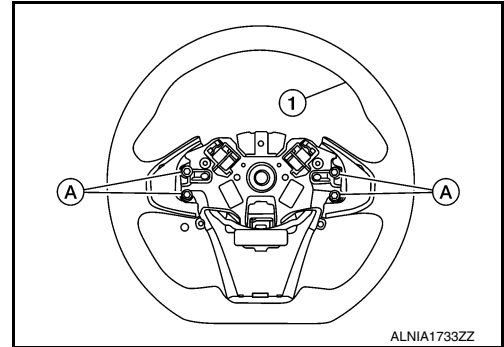

## INSTALLATION

Installation is in the reverse order of removal.

A  
B  
C  
D  
E  
F  
G  
H  
I  
J  
K  
L  
M  
N  
P

DAS

## WARNING BUZZER

< REMOVAL AND INSTALLATION >

[DRIVER ASSISTANCE SYSTEM]

---

### WARNING BUZZER

#### Exploded View

INFOID:000000011953218

The warning buzzer is an integral part of the combination meter. Refer to [IP-14. "Exploded View"](#).

#### Removal and Installation

INFOID:000000011953219

The warning buzzer is an integral part of the combination meter. Refer to [IP-15. "Removal and Installation"](#).

# SIDE RADAR

< REMOVAL AND INSTALLATION >

[DRIVER ASSISTANCE SYSTEM]

## SIDE RADAR

### Exploded View

INFOID:0000000011953220

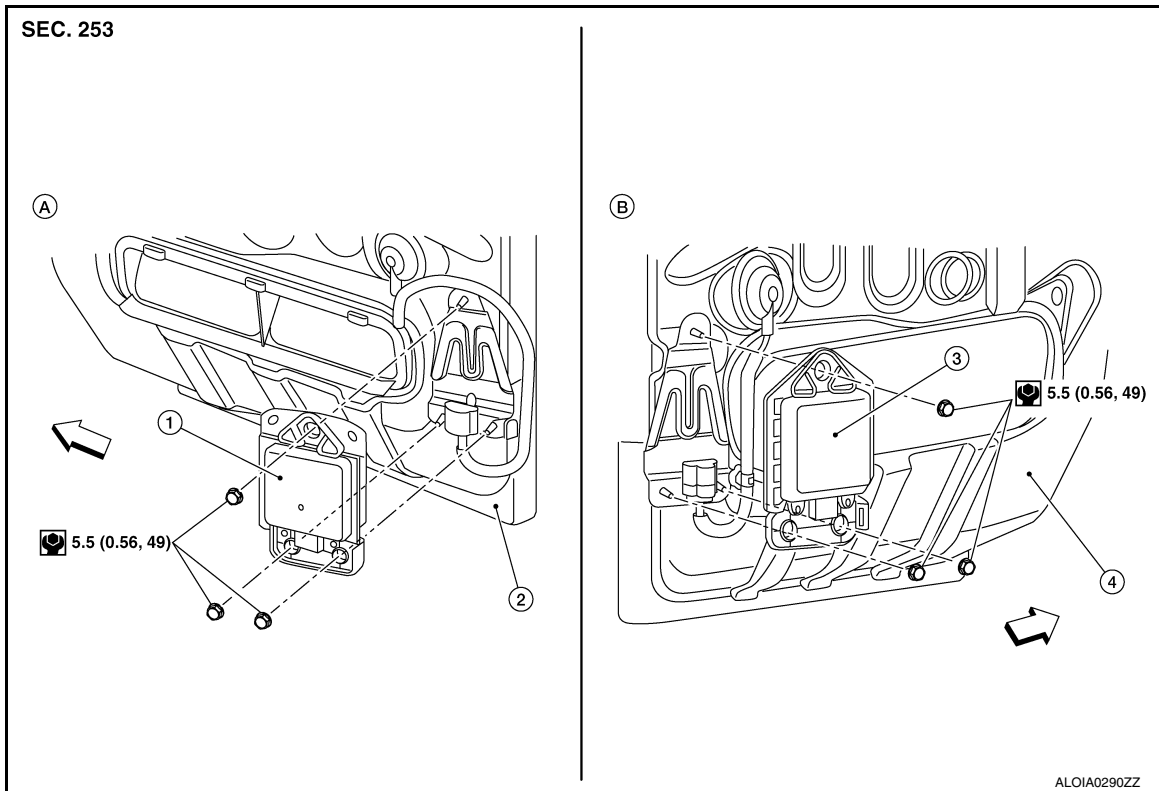

1. Side radar (LH)

2. Rear fender (LH)

3. Side radar (RH)

4. Rear fender (RH)

A. LH side

B. RH side

⇐ Front

## Removal and Installation

INFOID:0000000011953221

### REMOVAL

1. Remove rear bumper fascia. Refer to [INT-26. "Exploded View"](#).
2. Disconnect harness connector from side radar.
3. Remove nuts and remove side radar.

### INSTALLATION

Installation is in the reverse order of removal.

#### **CAUTION:**

**Do not use side radar if lens has flaws.**

#### **NOTE:**

Do not touch side radar lens and keep lens area clean.

A

B

C

D

E

F

G

H

I

J

K

L

M

N

DAS

P

# BLIND SPOT WARNING INDICATOR

< REMOVAL AND INSTALLATION >

[DRIVER ASSISTANCE SYSTEM]

## BLIND SPOT WARNING INDICATOR

Exploded View

INFOID:000000011953222

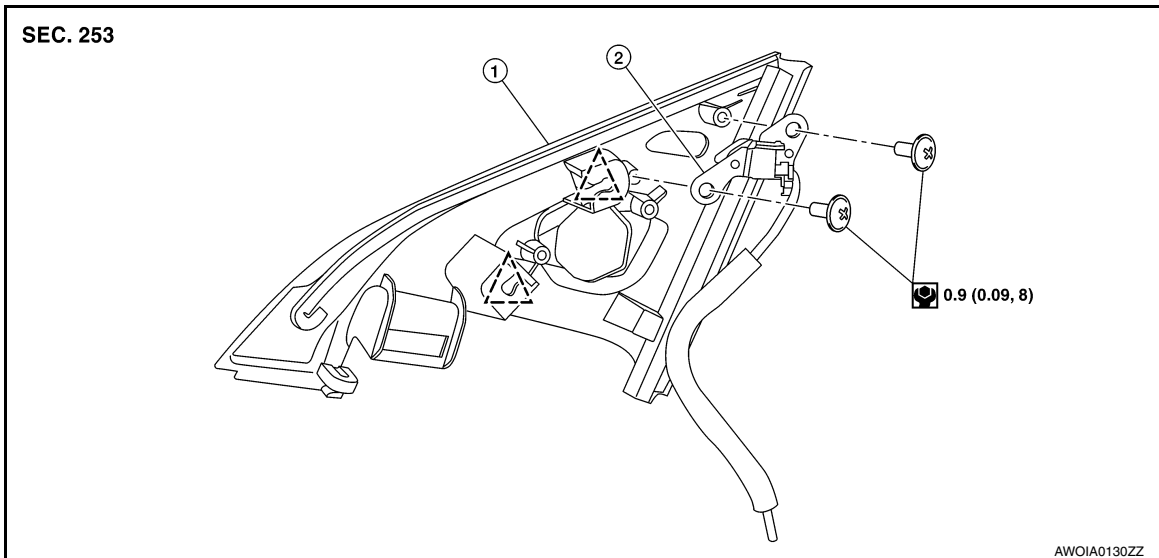

1. Door mirror corner finisher    2. Blind Spot Warning indicator     Clip

### Removal and Installation

INFOID:000000011953223

#### REMOVAL

##### NOTE:

LH shown; RH similar

1. Remove door mirror corner finisher. Refer to [MIR-21, "Removal and Installation"](#).
2. Remove screws and remove Blind Spot Warning indicator.

#### INSTALLATION

Installation in the reverse order of removal.

PRECAUTION

PRECAUTIONS

Precaution for Supplemental Restraint System (SRS) "AIR BAG" and "SEAT BELT PRE-TENSIONER"

INFOID:000000012271674

The Supplemental Restraint System such as "AIR BAG" and "SEAT BELT PRE-TENSIONER", used along with a front seat belt, helps to reduce the risk or severity of injury to the driver and front passenger for certain types of collision. Information necessary to service the system safely is included in the SR and SB section of this Service Manual.

**WARNING:**

- To avoid rendering the SRS inoperative, which could increase the risk of personal injury or death in the event of a collision which would result in air bag inflation, all maintenance must be performed by an authorized NISSAN/INFINITI dealer.
- Improper maintenance, including incorrect removal and installation of the SRS, can lead to personal injury caused by unintentional activation of the system. For removal of Spiral Cable and Air Bag Module, see the SR section.
- Do not use electrical test equipment on any circuit related to the SRS unless instructed to in this Service Manual. SRS wiring harnesses can be identified by yellow and/or orange harnesses or harness connectors.

PRECAUTIONS WHEN USING POWER TOOLS (AIR OR ELECTRIC) AND HAMMERS

**WARNING:**

- When working near the Airbag Diagnosis Sensor Unit or other Airbag System sensors with the Ignition ON or engine running, DO NOT use air or electric power tools or strike near the sensor(s) with a hammer. Heavy vibration could activate the sensor(s) and deploy the air bag(s), possibly causing serious injury.
- When using air or electric power tools or hammers, always switch the Ignition OFF, disconnect the battery and wait at least three minutes before performing any service.

Precaution for Work

INFOID:000000012271675

- When removing or disassembling each component, be careful not to damage or deform it. If a component may be subject to interference, be sure to protect it with a shop cloth.
- When removing (disengaging) components with a screwdriver or similar tool, be sure to wrap the component with a shop cloth or vinyl tape to protect it.
- Protect the removed parts with a shop cloth and prevent them from being dropped.
- Replace a deformed or damaged clip.
- If a part is specified as a non-reusable part, always replace it with a new one.
- Be sure to tighten bolts and nuts securely to the specified torque.
- After installation is complete, be sure to check that each part works properly.
- Follow the steps below to clean components:
  - Water soluble dirt:
    - Dip a soft cloth into lukewarm water, wring the water out of the cloth and wipe the dirty area.
    - Then rub with a soft, dry cloth.
  - Oily dirt:
    - Dip a soft cloth into lukewarm water with mild detergent (concentration: within 2 to 3%) and wipe the dirty area.
    - Then dip a cloth into fresh water, wring the water out of the cloth and wipe the detergent off.
    - Then rub with a soft, dry cloth.
  - Do not use organic solvent such as thinner, benzene, alcohol or gasoline.
  - For genuine leather seats, use a genuine leather seat cleaner.

A  
B  
C  
D  
E  
F  
G  
H  
I  
J  
K  
L  
M  
N  
P



# PRECAUTIONS

[CHASSIS CONTROL]

< PRECAUTION >

INFOID:000000012271676

## Precautions for Harness Repair

- Solder the repaired area and wrap tape around the soldered area.  
**NOTE:**  
A fray of twisted lines must be within 110 mm (4.33 in).

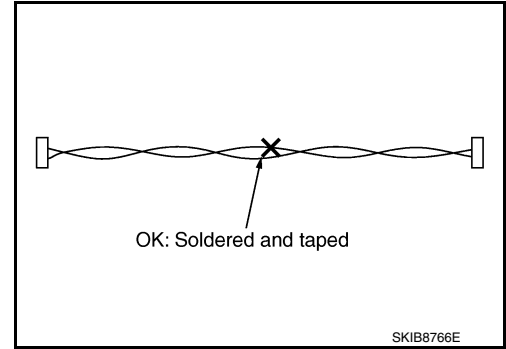

- Bypass connection is never allowed at the repaired area.  
**NOTE:**  
Bypass connection may cause CAN communication error. The spliced wire becomes separated and the characteristics of twisted line are lost.

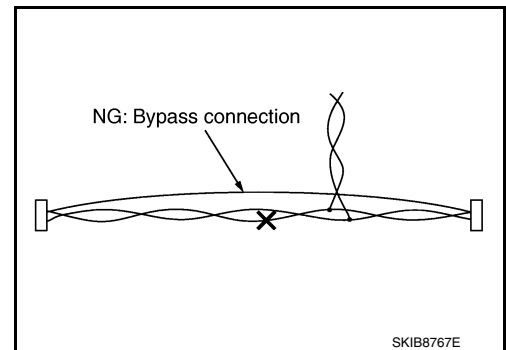

- Replace the applicable harness as an assembly if error is detected on the shield lines of CAN communication line.

## Precautions for Chassis control

INFOID:000000012271677

- Do not disassemble the chassis control module.
- Do not reuse if the chassis control module has been dropped.
- Do not perform ACTIVE TEST while driving the vehicle.
- Slight vibrations are felt on the brake pedal and the operation noises occur, when Active Trace Control and Active Ride Control function operates. This is not a malfunction because it is caused by the functions that are normally operated.
- Tachometer will rise and engine noise may be noticeable during Active Engine Brake function operation. This is not a malfunction because it is caused by the function that is normally operated.
- Active Trace Control, Active Ride Control and Active Engine Brake are not always activated in any driving conditions.



# PREPARATION

## PREPARATION

### Special Service Tool

INFOID:0000000012271678

The actual shape of the tools may differ from those illustrated here.

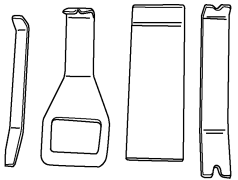
Tool number (TechMate No.) Tool name	Description
<p>— (J-46534) Trim Tool Set</p>  <p>AWJIA0483ZZ</p>	<p>Removing trim components</p>

A  
B  
C  
D  
E  
F  
G  
H  
I  
J  
K  
L  
M  
N  
P

DAS

< SYSTEM DESCRIPTION >

SYSTEM DESCRIPTION

COMPONENT PARTS

Component Parts Location

INFOID:000000012312091

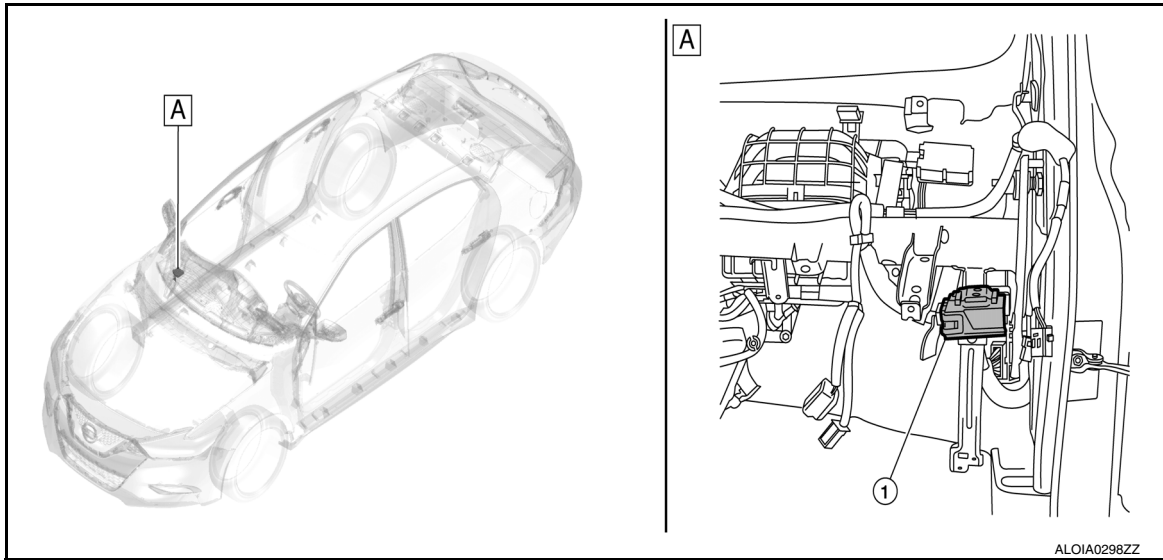

A. View with instrument panel assembly removed

No.	Component	Description
1.	Chassis control module	Refer to <a href="#">DAS-183. "System Description"</a> .

Chassis Control Module

INFOID:000000012312092

Chassis control module controls the following systems based on the signals from each sensor, each switch, and each control unit:

- Active trace control function
- Active engine control function
- Active ride control function

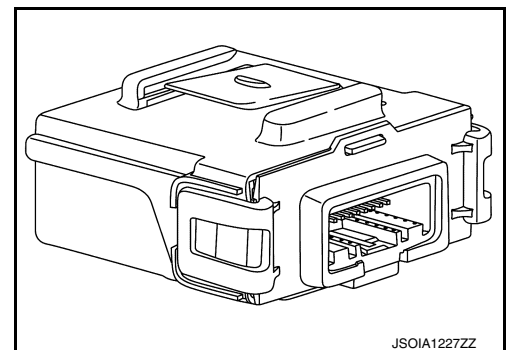

JSOIA1227ZZ

SYSTEM

System Description

INFOID:000000012312320

- Chassis control to integrally control the driving system was adopted.
- Chassis control module inputs the necessary information for control from CAN communication and each switch and integrally controls each system. Refer to the following table for systems controlled and input and output signals.

Function	Reference page
Active trace control function	<a href="#">DAS-186. "ACTIVE TRACE CONTROL (DYNAMIC CORNERING ENHANCEMENT) FUNCTION : System Description"</a>
Active engine brake control function	<a href="#">DAS-192. "ACTIVE ENGINE BRAKE FUNCTION : System Description"</a>
Active ride control function	<a href="#">DAS-195. "ACTIVE RIDE CONTROL FUNCTION : System Description"</a>

SYSTEM DIAGRAM

NOTE:

TCM is applied to CVT models.

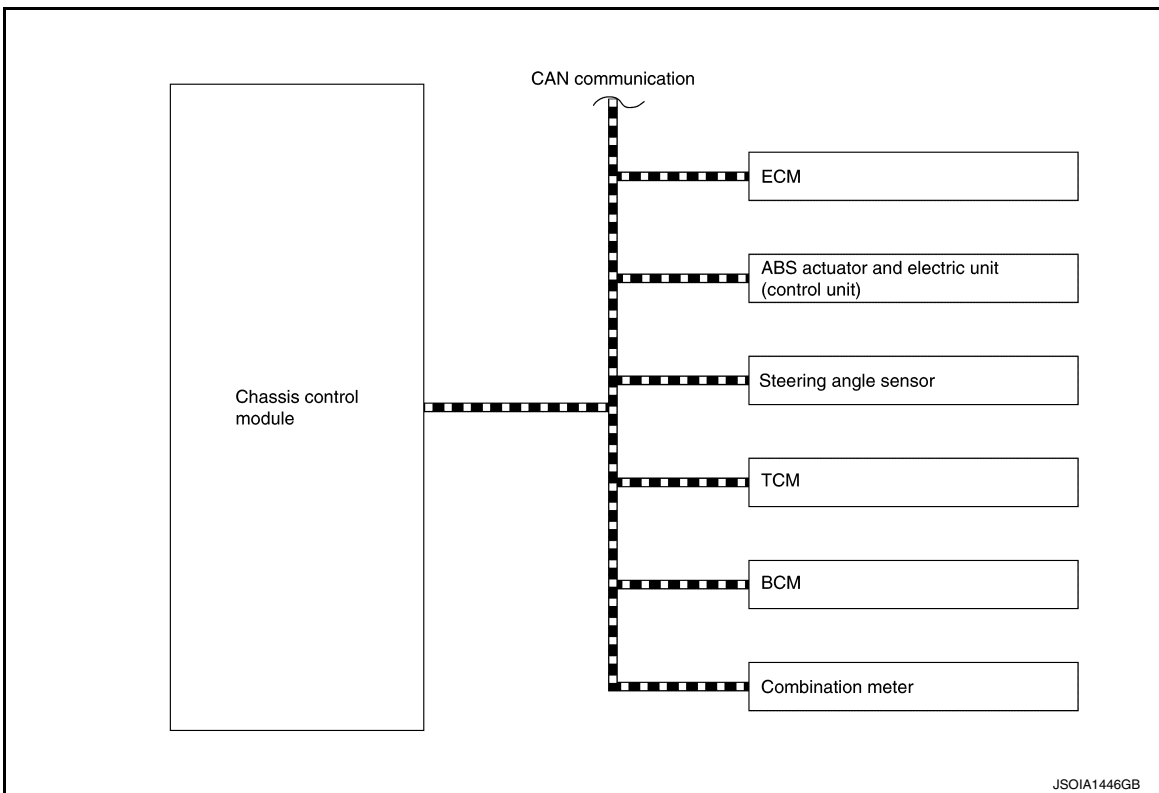

INPUT SIGNAL AND OUTPUT SIGNAL

Major signal transmission between each unit via communication lines is shown in the following table.

DAS

# SYSTEM

< SYSTEM DESCRIPTION >

[CHASSIS CONTROL]

Component parts	Signal description
ECM	<p>Transmits the following signals to chassis control module via CAN communication:</p> <ul style="list-style-type: none"> <li>• Accelerator pedal position signal</li> <li>• Engine speed signal</li> <li>• Estimate drive torque signal</li> <li>• Request drive torque signal</li> <li>• ECM malfunction signal</li> <li>• Request drive torque status signal</li> </ul>
ABS actuator and electric unit (control unit)	<p>Transmits the following signals to chassis control module via CAN communication:</p> <ul style="list-style-type: none"> <li>• Front LH wheel speed signal</li> <li>• Front RH wheel speed signal</li> <li>• Rear LH wheel speed signal</li> <li>• Rear RH wheel speed signal</li> <li>• TCS operation signal</li> <li>• VDC operation signal</li> <li>• Side G signal</li> <li>• VDC OFF switch signal</li> <li>• Brake fluid pressure signal</li> <li>• Steering angle signal</li> <li>• VDC accept permission signal</li> <li>• ABS operation signal</li> <li>• Vehicle speed signal</li> <li>• Decel G signal</li> <li>• ABS malfunction signal</li> <li>• VDC malfunction signal</li> <li>• TCS malfunction signal</li> <li>• Yaw rate signal</li> </ul> <p>Receives the following signals from chassis control module via CAN communication:</p> <ul style="list-style-type: none"> <li>• Active trace control signal</li> <li>• Active engine brake control signal</li> <li>• Active ride control signal</li> </ul>
BCM	<p>Transmits the following signals to chassis control module via CAN communication:</p> <ul style="list-style-type: none"> <li>• Stop lamp switch signal</li> <li>• Turn signal switch signal</li> <li>• Brake pedal position switch signal</li> <li>• BCM malfunction signal</li> </ul>
TCM	<p>Transmits the following signals to chassis control module via CAN communication:</p> <ul style="list-style-type: none"> <li>• Current gear position signal</li> <li>• CVT target gear ratio signal</li> <li>• CVT accept permission signal</li> <li>• Input speed signal</li> <li>• TCM malfunction signal</li> </ul>
Combination meter	<p>Transmits the following signals to chassis control module via CAN communication:</p> <ul style="list-style-type: none"> <li>• Active trace control setting change request signal</li> <li>• Active engine brake setting change request signal</li> <li>• Combination meter malfunction signal</li> </ul> <p>Receives the chassis control malfunction display request signal from the chassis control module via CAN communication.</p>
Steering angle sensor	<p>Transmits the steering angle sensor signal to the chassis control module via CAN communication.</p>

## Fail-Safe (Chassis Control Module)

INFOID:000000012338480

When a malfunction occurs in the chassis control module, the master warning lamp turns ON and an interrupt is displayed on the information display of the combination meter.

# SYSTEM

< SYSTEM DESCRIPTION >

[CHASSIS CONTROL]

DTC	Vehicle condition	A
C1B92-00	The following functions are suspended: <ul style="list-style-type: none"> <li>• Active Trace Control</li> <li>• Active Ride Control</li> <li>• Active Engine Brake</li> </ul>	B
C1B93-00	The following functions are suspended: <ul style="list-style-type: none"> <li>• Active Trace Control</li> <li>• Active Ride Control (engine)</li> <li>• Active Engine Brake</li> </ul>	C
C1B94-00	The following functions are suspended: <ul style="list-style-type: none"> <li>• Active Trace Control</li> <li>• Active Ride Control (engine)</li> </ul>	D
C1B95-00	The following functions are suspended: <ul style="list-style-type: none"> <li>• Active Trace Control</li> <li>• Active Ride Control (brake)</li> </ul>	E
C1B99-00	The following functions are suspended: <ul style="list-style-type: none"> <li>• Active Trace Control</li> <li>• Active Ride Control</li> <li>• Active Engine Brake</li> </ul>	F
C1BA0-00	The following functions are suspended: <ul style="list-style-type: none"> <li>• Active Trace Control</li> <li>• Active Ride Control (brake)</li> </ul>	G
C1BA2-00	The following functions are suspended: <ul style="list-style-type: none"> <li>• Active Trace Control</li> <li>• Active Ride Control (engine)</li> </ul>	H
C1BA5-00	Normal control	
C1BAB-00	The following functions are suspended: <ul style="list-style-type: none"> <li>• Active Trace Control</li> <li>• Active Ride Control (engine)</li> </ul>	I
C1BB2-00	The following functions are suspended: <ul style="list-style-type: none"> <li>• Active Trace Control</li> <li>• Active Ride Control</li> <li>• Active Engine Brake</li> </ul>	J
C1BB3-00		
C1BB4-00		
C1BB5-00		
C1BB6-00	Normal control	
C1BB7-00	The following functions are suspended: <ul style="list-style-type: none"> <li>• Active Trace Control</li> <li>• Active Ride Control</li> <li>• Active Engine Brake</li> </ul>	L
C1BB8-00		
C1BB9-00		
C1BBA-00		
C1BBB-00	Normal control	M
C1BBC-00		
C1BBD-00	The following functions are suspended: <ul style="list-style-type: none"> <li>• Active Trace Control</li> <li>• Active Ride Control</li> <li>• Active Engine Brake</li> </ul>	N
C1BC0-00	The following functions are suspended: <ul style="list-style-type: none"> <li>• Active Trace Control</li> <li>• Active Ride Control</li> </ul>	P
C1BC1-00		
C1BC2-00		
C1BC3-00		
C1BC4-00	The following function is suspended: <ul style="list-style-type: none"> <li>• Active Ride Control (brake)</li> </ul>	
C1BC5-00	The following functions is suspended: <ul style="list-style-type: none"> <li>• Active Trace Control</li> </ul>	

DAS

# SYSTEM

< SYSTEM DESCRIPTION >

[CHASSIS CONTROL]

DTC	Vehicle condition
C1BC6-00	The following functions are suspended: <ul style="list-style-type: none"><li>• Active Trace Control</li><li>• Active Ride Control (brake)</li></ul>
U1A34-00	The following functions are suspended: <ul style="list-style-type: none"><li>• Active Trace Control</li><li>• Active Ride Control</li><li>• Active Engine Brake</li></ul>
U1A35-00	
U1A36-00	
U1A39-00	Normal control
U1A3B-00	The following functions are suspended: <ul style="list-style-type: none"><li>• Active Trace Control</li><li>• Active Ride Control (brake)</li><li>• Active Engine Brake</li></ul>
U1A42-00	The following functions are suspended: <ul style="list-style-type: none"><li>• Active Trace Control</li><li>• Active Ride Control (engine)</li></ul>
U1A43-00	
U1A48-00	The following functions are suspended: <ul style="list-style-type: none"><li>• Active Trace Control</li><li>• Active Ride Control</li><li>• Active Engine Brake</li></ul>
U1A4A-00	
U1A4B-00	
U1A4E-00	The following function is suspended: <ul style="list-style-type: none"><li>• Active Ride Control</li></ul>

## ACTIVE TRACE CONTROL (DYNAMIC CORNERING ENHANCEMENT) FUNCTION

### ACTIVE TRACE CONTROL (DYNAMIC CORNERING ENHANCEMENT) FUNCTION

#### : System Description

INFOID:000000012312323

- The steering operation condition by the driver and the information from multiple sensors are computed by the chassis control module, and a command is transmitted to the ABS actuator and electric unit (control unit).
- The ABS actuator and electric unit (control unit) controls the brake based on the command from the chassis control module.
- When cornering, driver operation is reduced and vehicle behavior is smoothed.
- When the VDC function is turned OFF with the VDC OFF switch, active trace control function also turns OFF.
- The active trace control function can be turned ON/OFF by operating the steering switch. However, even when turned OFF, a portion of functions (emergency avoidance, etc.) turn ON.
- When a malfunction occurs in active trace control function, the master warning lamp illuminates and the information display in the combination meter informs the driver.

#### NOTE:

- Active trace control function may not be effective in all driving environments (traction conditions, etc.).
- When active trace control function operates, vibration may be transmitted to the brake pedal, an operation sound may be heard, and a feeling of deceleration may be felt. These are not symptoms of malfunctions and indicate normal operating conditions.
- Even when active trace control function OFF is selected with chassis control setting, it is not turned completely OFF continues to provide assistance in scenes where steering load is in the high excess range (emergency avoidance, etc.).

#### OPERATION CHARACTERISTICS

# SYSTEM

## < SYSTEM DESCRIPTION >

## [CHASSIS CONTROL]

- This performs assistance when switching from deceleration (brake operation) to acceleration (accelerator operation) when driving on a curve. It operates the brake automatically to stabilize cornering and smoothens acceleration in the longitudinal and lateral directions.

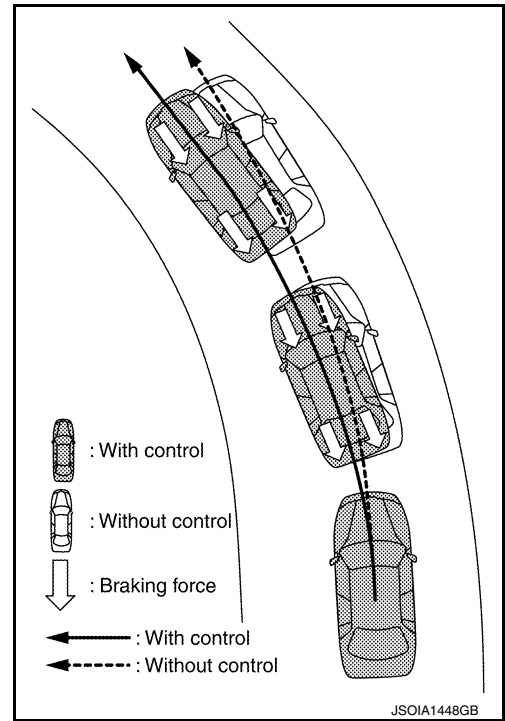

- The brake is controlled according to the steering operation condition of the driver and the cornering condition of the vehicle.

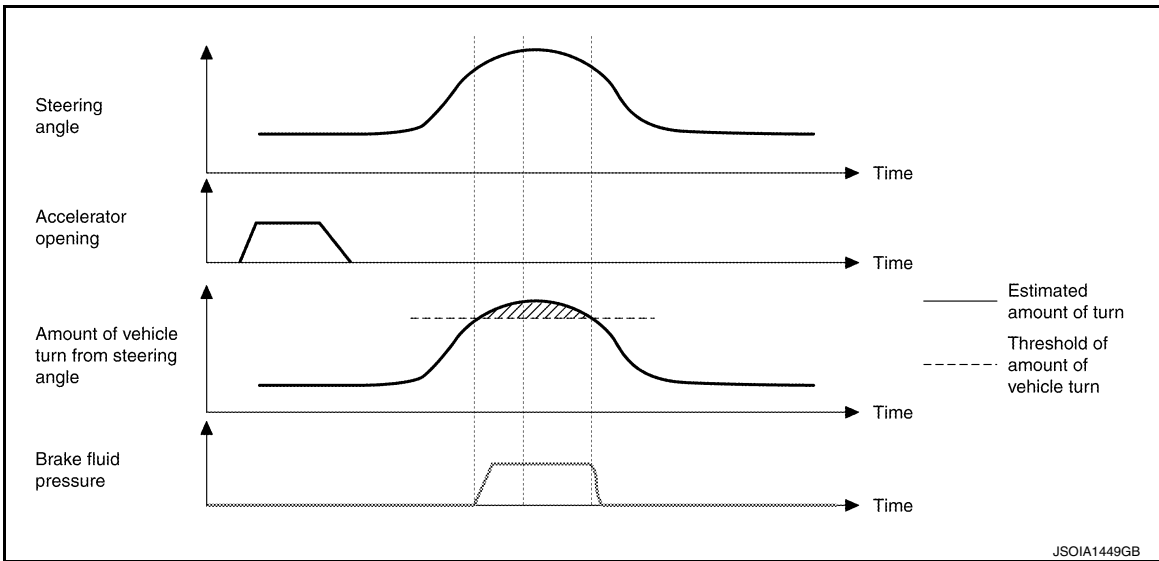

A  
B  
C  
D  
E  
F  
G  
H  
I  
J  
K  
L  
M  
N  
P

DAS

# SYSTEM

## < SYSTEM DESCRIPTION >

- For the purpose of improving responsiveness during excessive steering operation, such as emergency avoidance steering, etc., the brake is applied to the inside wheel of the steering direction and causes turning momentum to be generated.

## [CHASSIS CONTROL]

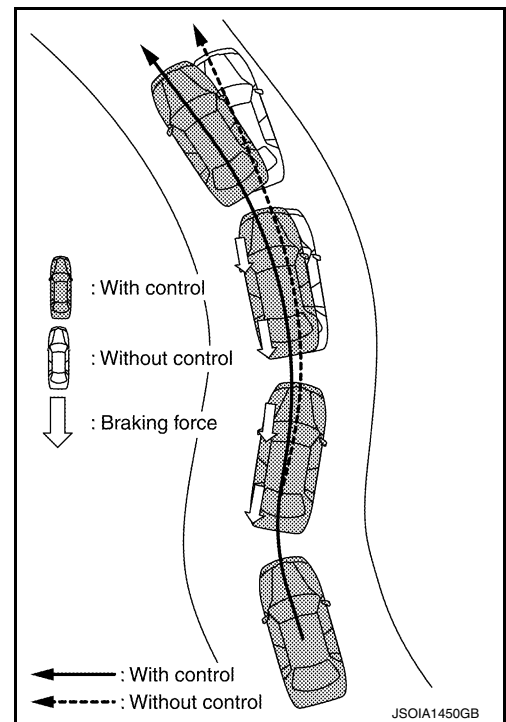

- The brake is controlled according to the steering operation condition of the driver.

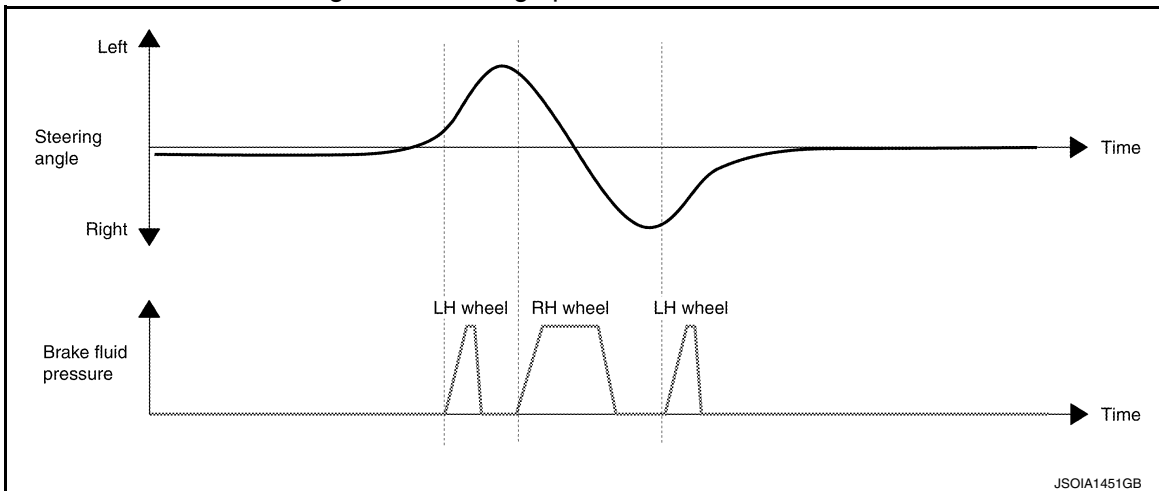



# SYSTEM

## < SYSTEM DESCRIPTION >

## [CHASSIS CONTROL]

- When driving on a curve, change of the steering operation angle is controlled, vehicle movement is smoothened and cornering with a stable feeling is realized simultaneously by controlling the brake on the inner wheel, according to accelerator operation.

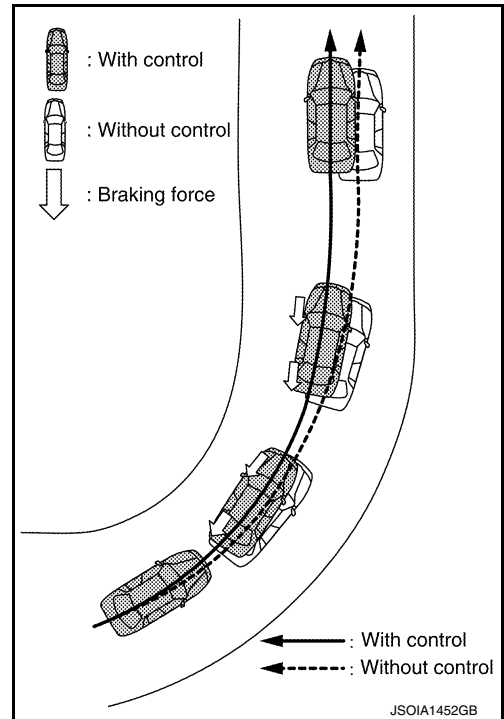

- The brake is controlled according to the steering operation condition of the driver and the cornering condition of the vehicle.

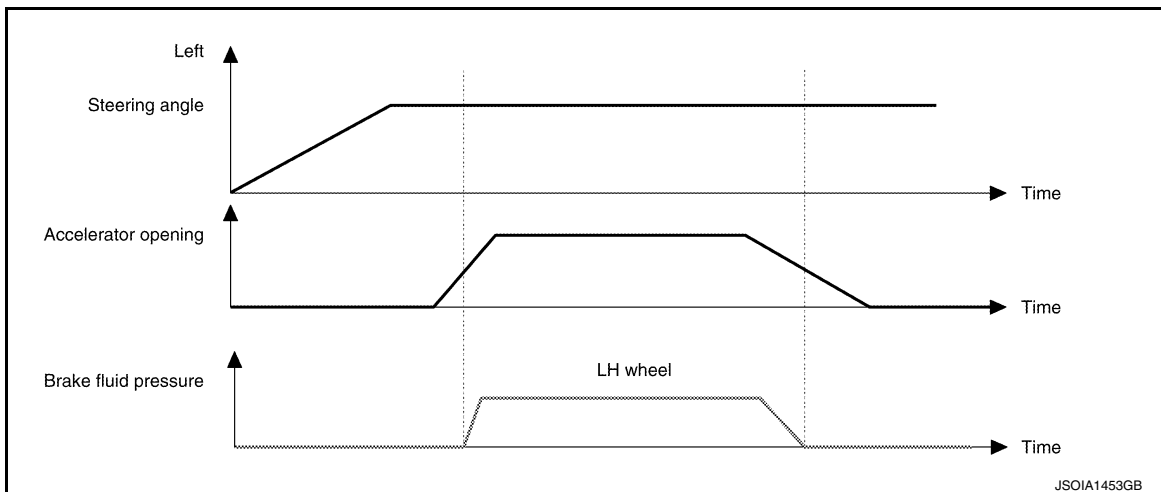

A  
B  
C  
D  
E  
F  
G  
H  
I  
J  
K  
L  
M  
N  
P

DAS

# SYSTEM

## < SYSTEM DESCRIPTION >

## [CHASSIS CONTROL]

- When performing quick lane changes and other excessive steering operations, the brake is operated automatically, and erratic vehicle behavior due to steering operation is reduced.

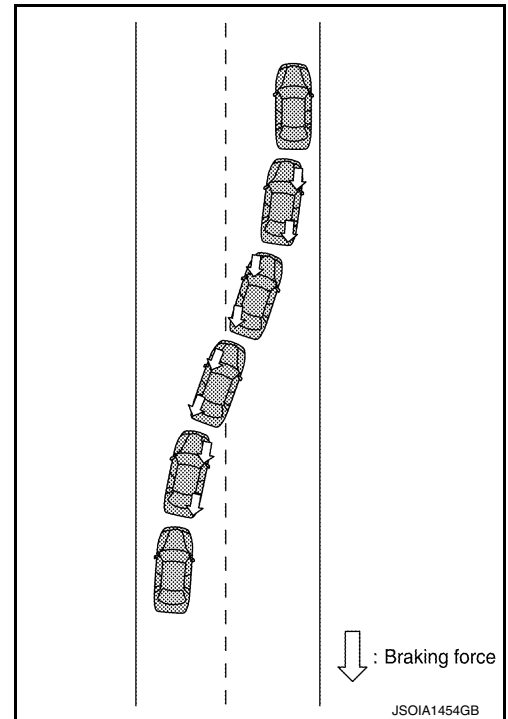

- The brake is controlled according to the steering operation condition of the driver and the cornering condition of the vehicle.

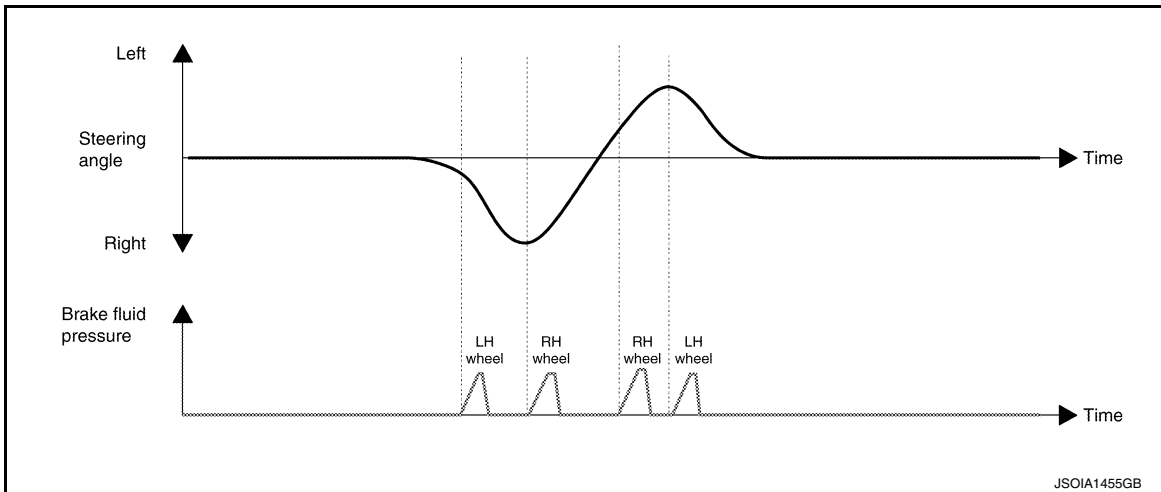

## SYSTEM DIAGRAM

### NOTE:

TCM is applied to CVT models.

# SYSTEM

< SYSTEM DESCRIPTION >

[CHASSIS CONTROL]

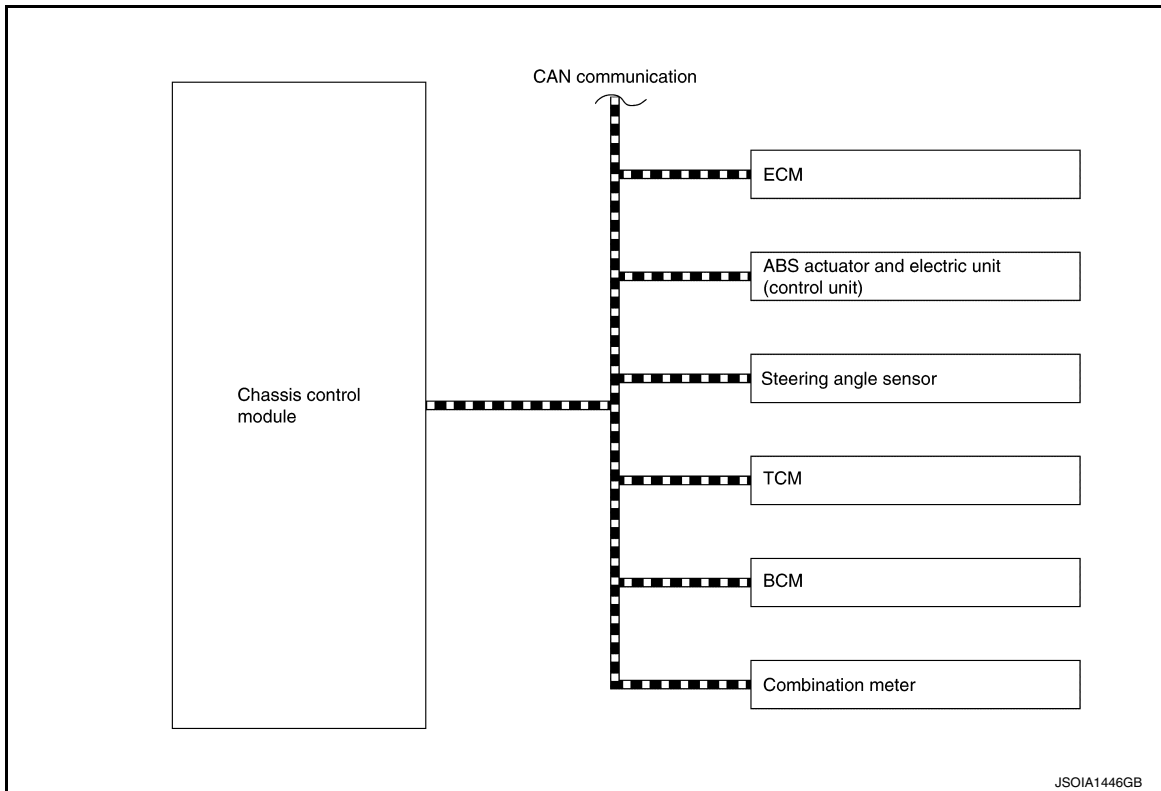

## INPUT SIGNAL AND OUTPUT SIGNAL

Major signal transmission between each unit via communication lines is shown in the following table:

Component parts	Signal description
ECM	Transmits the following signals to chassis control module via CAN communication: <ul style="list-style-type: none"> <li>• Accelerator pedal position signal</li> <li>• Engine speed signal</li> <li>• Estimate drive torque signal</li> <li>• Request drive torque signal</li> <li>• Request drive torque status signal</li> </ul>
ABS actuator and electric unit (control unit)	Transmits the following signals to chassis control module via CAN communication: <ul style="list-style-type: none"> <li>• Front LH wheel speed signal</li> <li>• Front RH wheel speed signal</li> <li>• Rear LH wheel speed signal</li> <li>• Rear RH wheel speed signal</li> <li>• TCS operation signal</li> <li>• VDC operation signal</li> <li>• Side G signal</li> <li>• VDC OFF switch signal</li> <li>• Brake fluid pressure signal</li> <li>• Steering angle signal</li> <li>• VDC accept permission signal</li> </ul> Receives the active trace control signal from chassis control module via CAN communication.
BCM	Transmits the stop lamp switch signal to chassis control module via CAN communication.
IPDM E/R	Transmits the ignition switch ON signal to chassis control module via CAN communication.
TCM	Transmits the following signals to chassis control module via CAN communication: <ul style="list-style-type: none"> <li>• Current gear position signal</li> <li>• CVT target gear ratio signal</li> </ul>
Combination meter	Transmits the active trace control setting change request signal to chassis control module via CAN communication. Receives the chassis control malfunction display request signal from chassis control module via CAN communication.
Steering angle sensor	Transmits the steering angle sensor signal to chassis control module via CAN communication.

A  
B  
C  
D  
E  
F  
G  
H  
I  
J  
K  
L  
M  
N  
P

DAS

ACTIVE ENGINE BRAKE FUNCTION

ACTIVE ENGINE BRAKE FUNCTION : System Description

INFOID:0000000012312324

The active engine control function can be turned ON/OFF by operating the steering switch.

CORNERING CONTROL

- For the purpose of reducing the operation of switching to depress the brake pedal during cornering, the operation information of the driver is computed by the chassis control module and a command is transmitted to TCM.
- Based on the command from the chassis control module, TCM shifts the gear ratio of the transaxle to the low side and applies the engine brake.

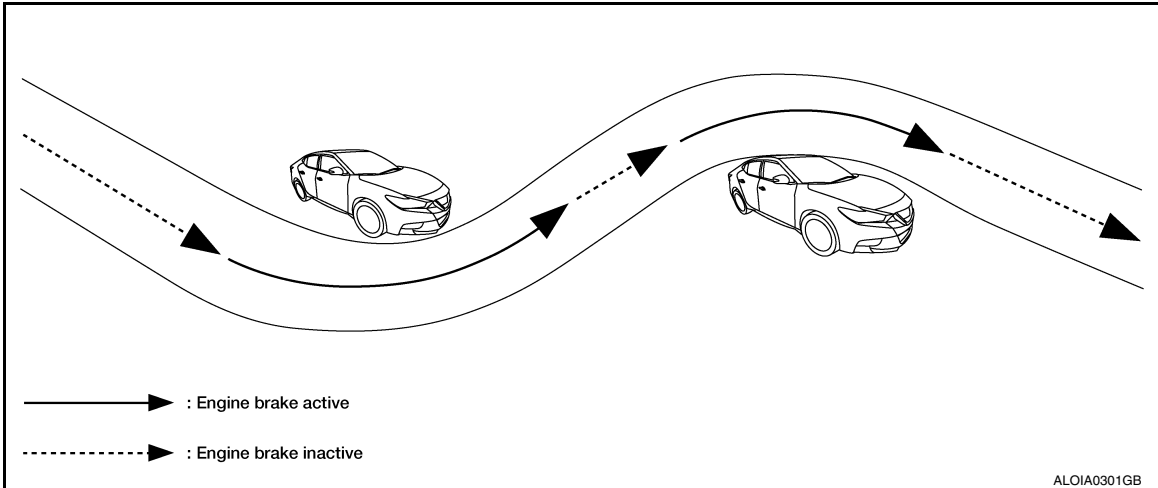

- The transaxle is controlled according to the steering operation of the driver as well as the accelerator pedal condition and cornering condition of the vehicle.

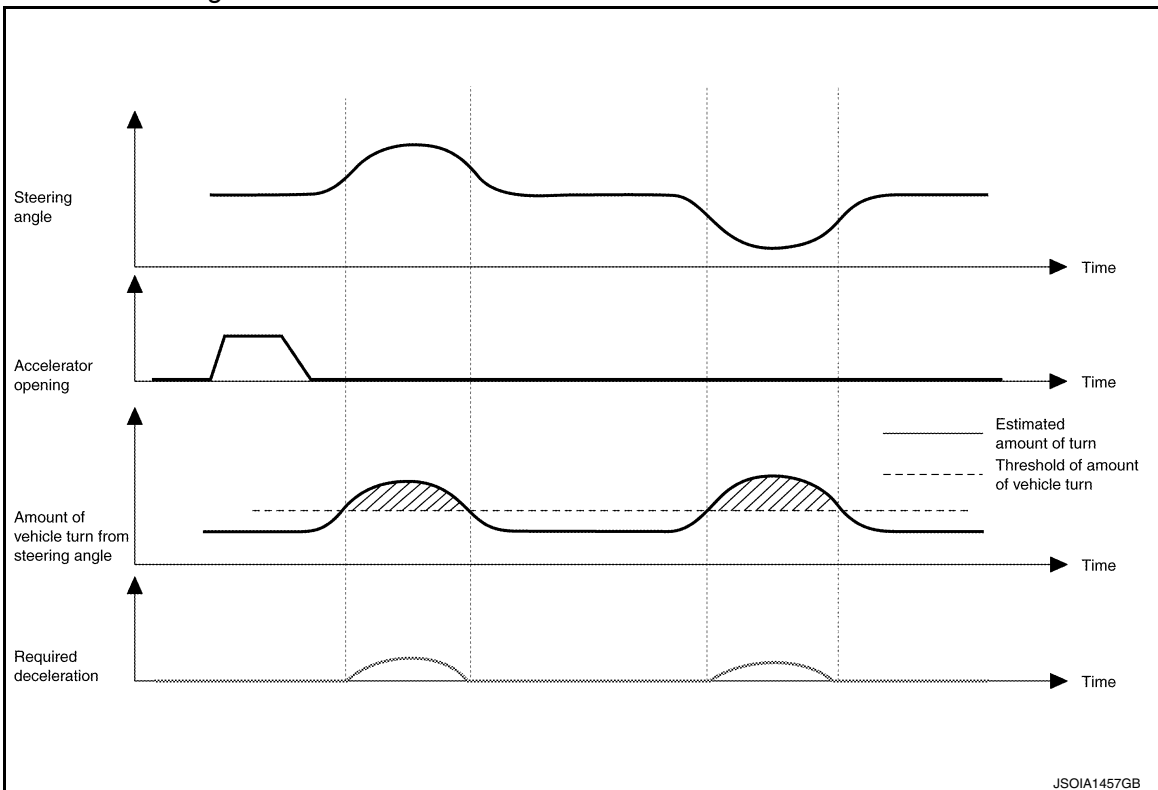

BRAKING CONTROL

- For the purpose of improving the feeling of effectiveness of the brake when decelerating, the brake operation amount of the driver is computed by the chassis control module and a command is transmitted to TCM.

# SYSTEM

## [CHASSIS CONTROL]

### < SYSTEM DESCRIPTION >

- Based on the command from the chassis control module, TCM shifts the gear ratio of the transaxle to the low side and applies the engine brake.

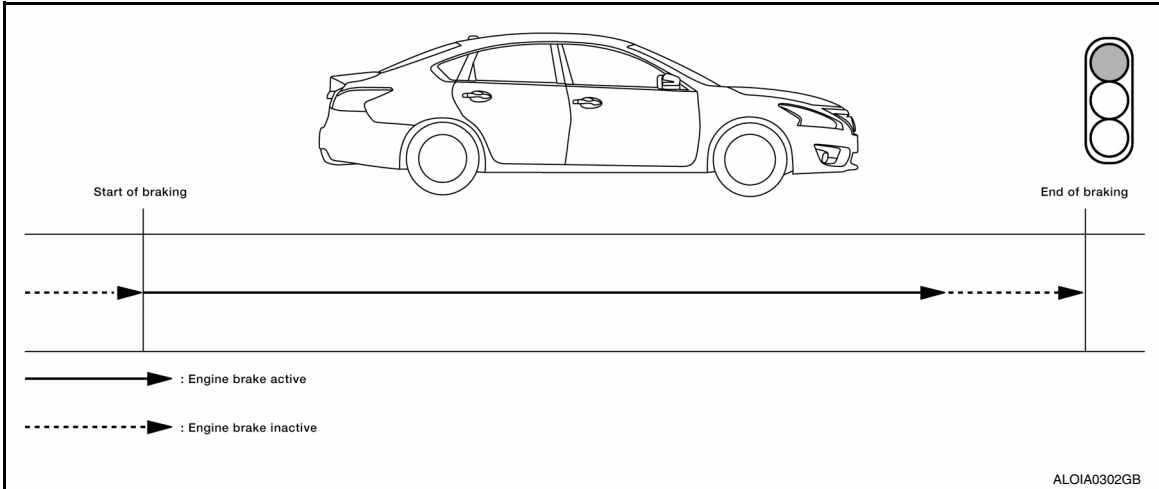

- The transaxle is controlled according to the brake condition.

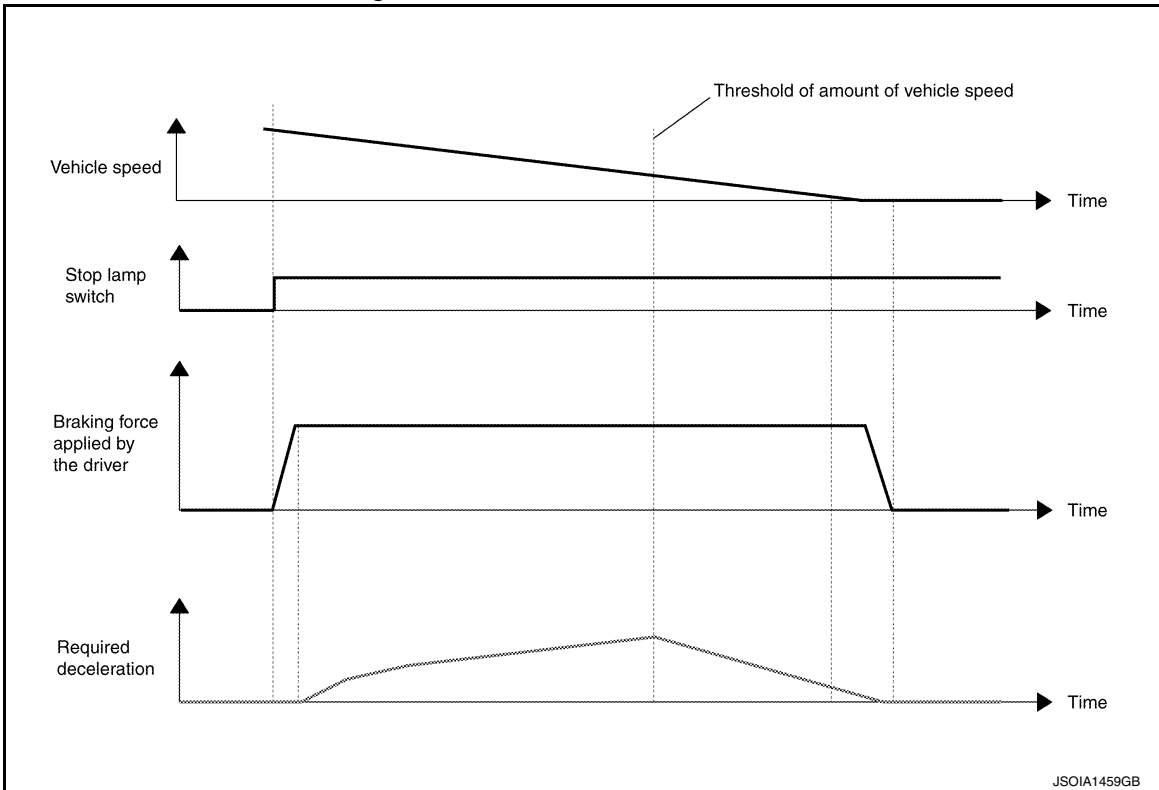

### SYSTEM DIAGRAM

#### NOTE:

TCM is applied to CVT models.

A  
B  
C  
D  
E  
F  
G  
H  
I  
J  
K  
L  
M  
N  
P

DAS

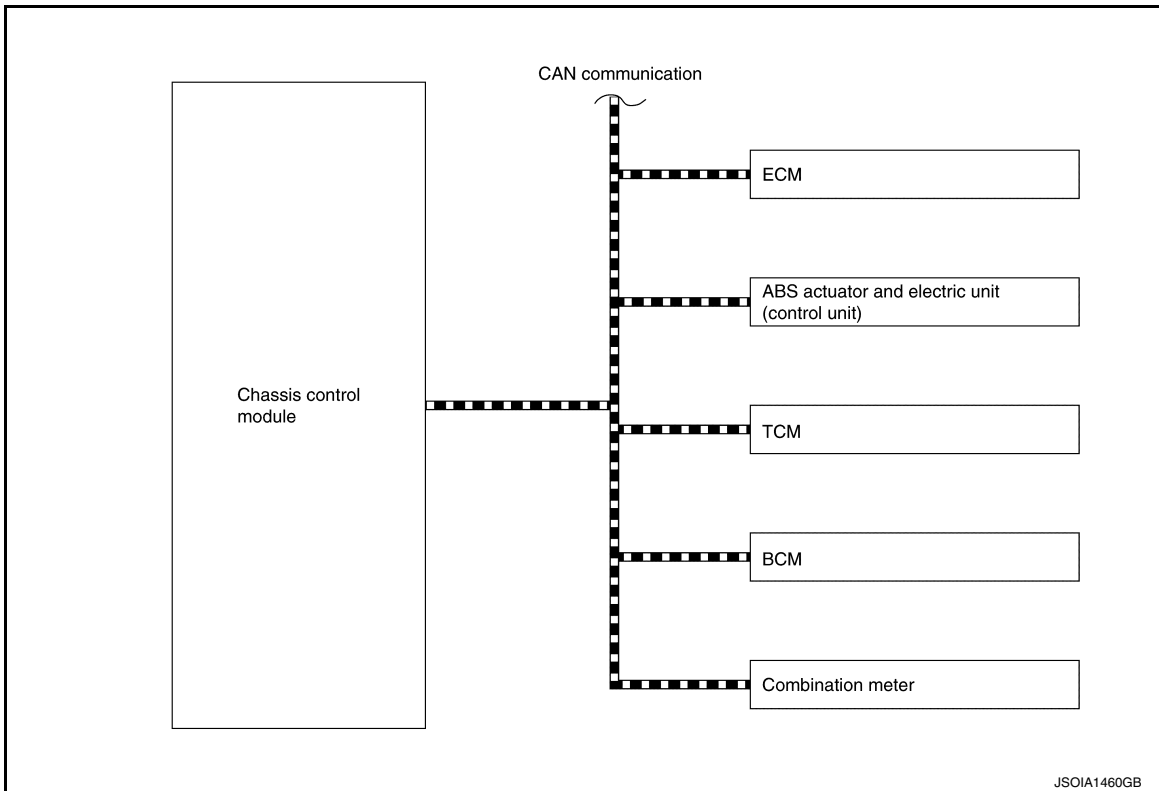

**INPUT SIGNAL AND OUTPUT SIGNAL**

Major signal transmission between each unit via communication lines is shown in the following table:

Component parts	Signal description
ECM	Mainly transmits the following signals to chassis control module via CAN communication: <ul style="list-style-type: none"> <li>• Accelerator pedal position signal</li> <li>• Estimate drive torque signal</li> <li>• Request drive torque status signal</li> </ul>
ABS actuator and electric unit (control unit)	Mainly transmits the following signals to chassis control module via CAN communication: <ul style="list-style-type: none"> <li>• Front LH wheel speed signal</li> <li>• Front RH wheel speed signal</li> <li>• Rear LH wheel speed signal</li> <li>• Rear RH wheel speed signal</li> <li>• VDC operation signal</li> <li>• Side G signal</li> <li>• Brake fluid pressure signal</li> <li>• Steering angle signal</li> </ul> Mainly receives the following signal from chassis control module via CAN communication: <ul style="list-style-type: none"> <li>• Active engine brake control signal</li> </ul>
BCM	Mainly transmits the following signal to chassis control module via CAN communication: <ul style="list-style-type: none"> <li>• Stop lamp switch signal</li> </ul>
IPDM E/R	Mainly transmits the following signal to chassis control module via CAN communication: <ul style="list-style-type: none"> <li>• Ignition switch ON signal</li> </ul>
TCM	Mainly transmits the following signal to chassis control module via CAN communication: <ul style="list-style-type: none"> <li>• CVT accept permission signal</li> </ul>
Combination meter	Mainly transmits the following signal to chassis control module via CAN communication: <ul style="list-style-type: none"> <li>• Active engine brake setting change request signal</li> </ul> Mainly receives the following signals from chassis control module via CAN communication: <ul style="list-style-type: none"> <li>• Curve display request signal</li> <li>• Tire display request signal</li> <li>• Active engine brake setting display request signal</li> </ul>

**ACTIVE RIDE CONTROL FUNCTION**

## ACTIVE RIDE CONTROL FUNCTION : System Description

INFOID:000000012312325

- When the VDC function is turned OFF by operation of VDC OFF switch, active ride control function also turns OFF.
- When a malfunction occurs in active ride control function, the master warning lamp illuminates and the information display in the combination meter informs the driver.

**NOTE:**

Active ride control function may not be effective in all driving environments (traction conditions, etc.).

### ENGINE CONTROL

#### Riding Comfort Improvement

- When driving on an uneven road surface, the rotation of each wheel, the steering angle, and the requested traction torque are computed by the chassis control module and a command is transmitted to ECM.
- Based on the command from the chassis control module, ECM corrects the engine torque that is outputted.
- By correcting the engine torque that is outputted, the load of weight on the front and rear wheels stabilizes and riding comfort is improved.

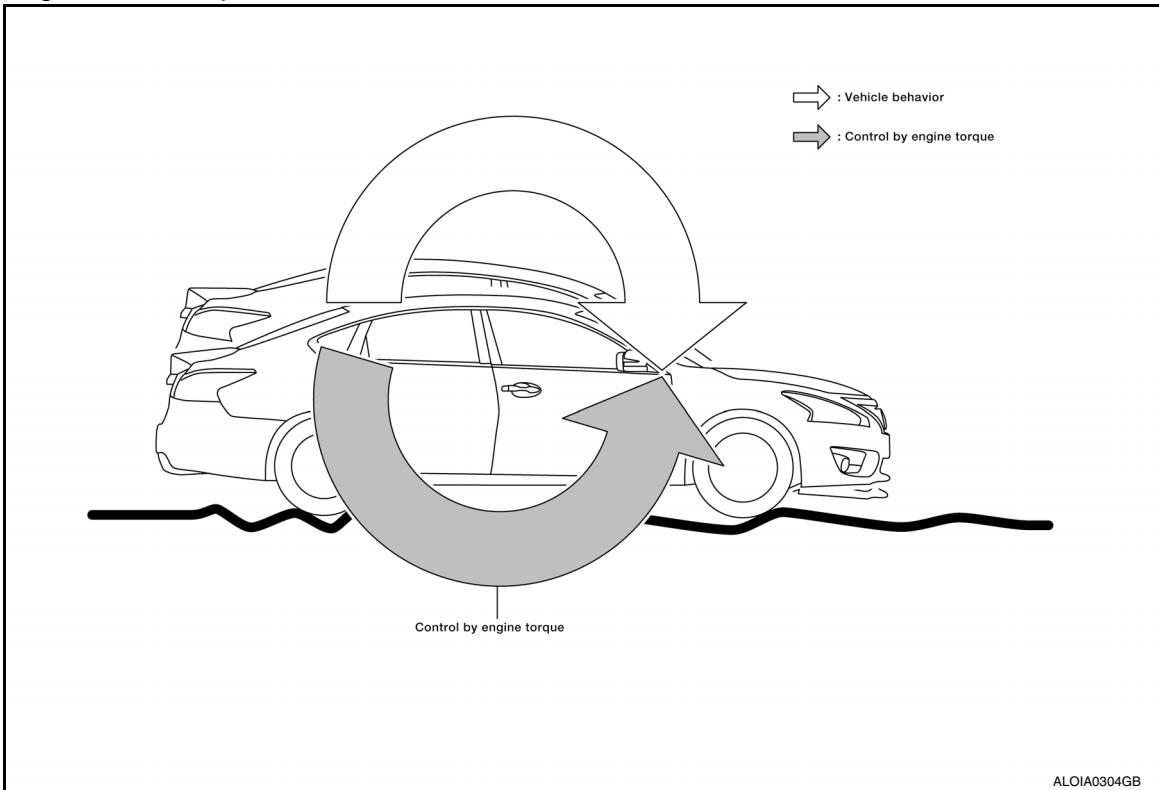

A  
B  
C  
D  
E  
F  
G  
H  
I  
J  
K  
L  
M  
N  
P

DAS

- Engine torque is corrected according to driving conditions.

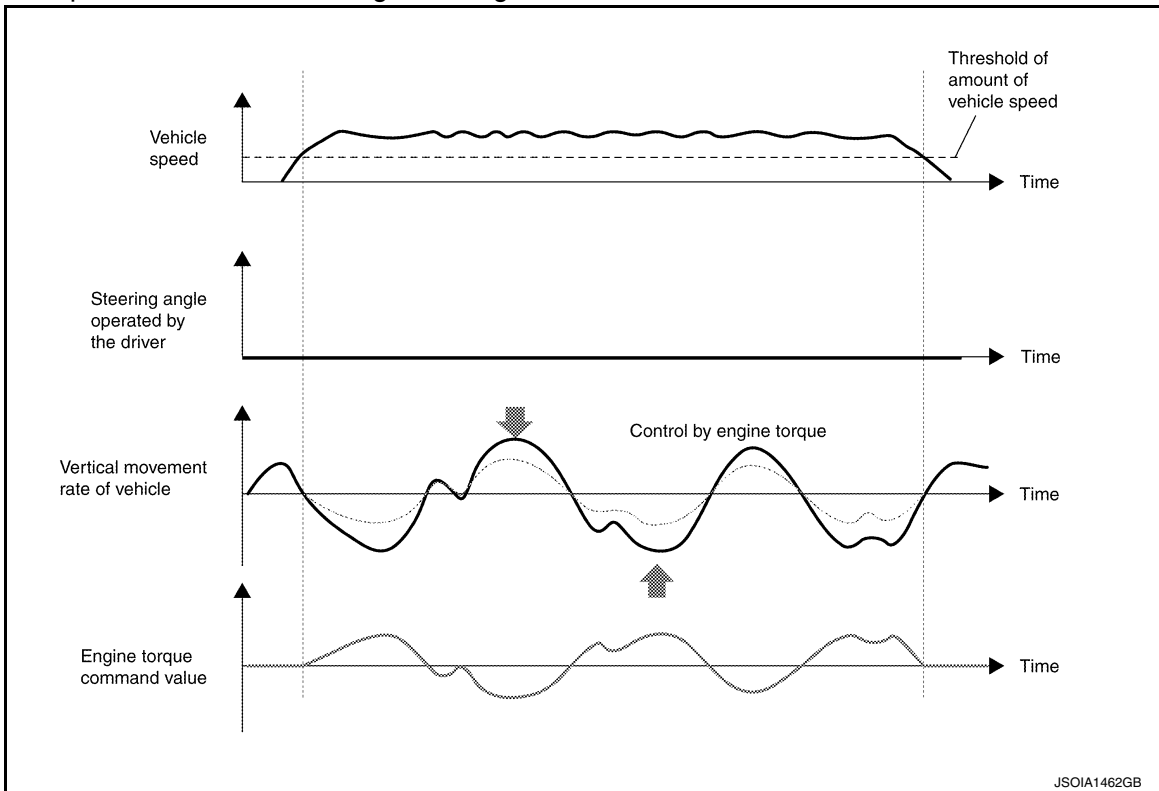

### Steering Stability

- The rotation of each wheel, the steering angle, and the requested traction torque are computed by the chassis control module and a command is transmitted to ECM.
- Based on the command from the chassis control module, ECM corrects the engine torque that is outputted.
- By correcting the engine torque that is outputted, vehicle behavior during cornering is smoothed.

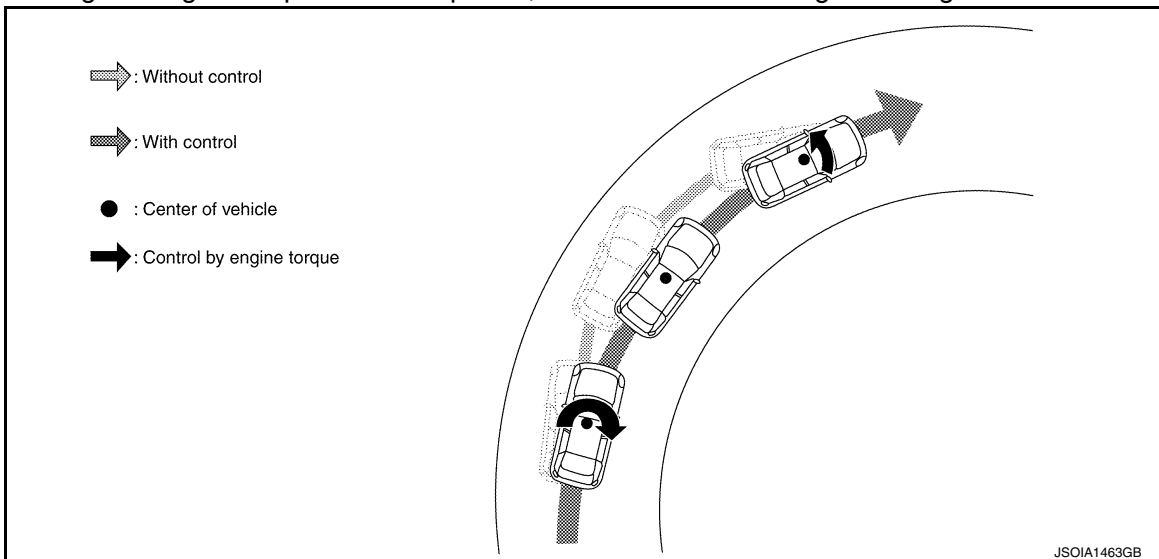



# SYSTEM

## < SYSTEM DESCRIPTION >

## [CHASSIS CONTROL]

- Engine torque is corrected according to steering operation conditions.

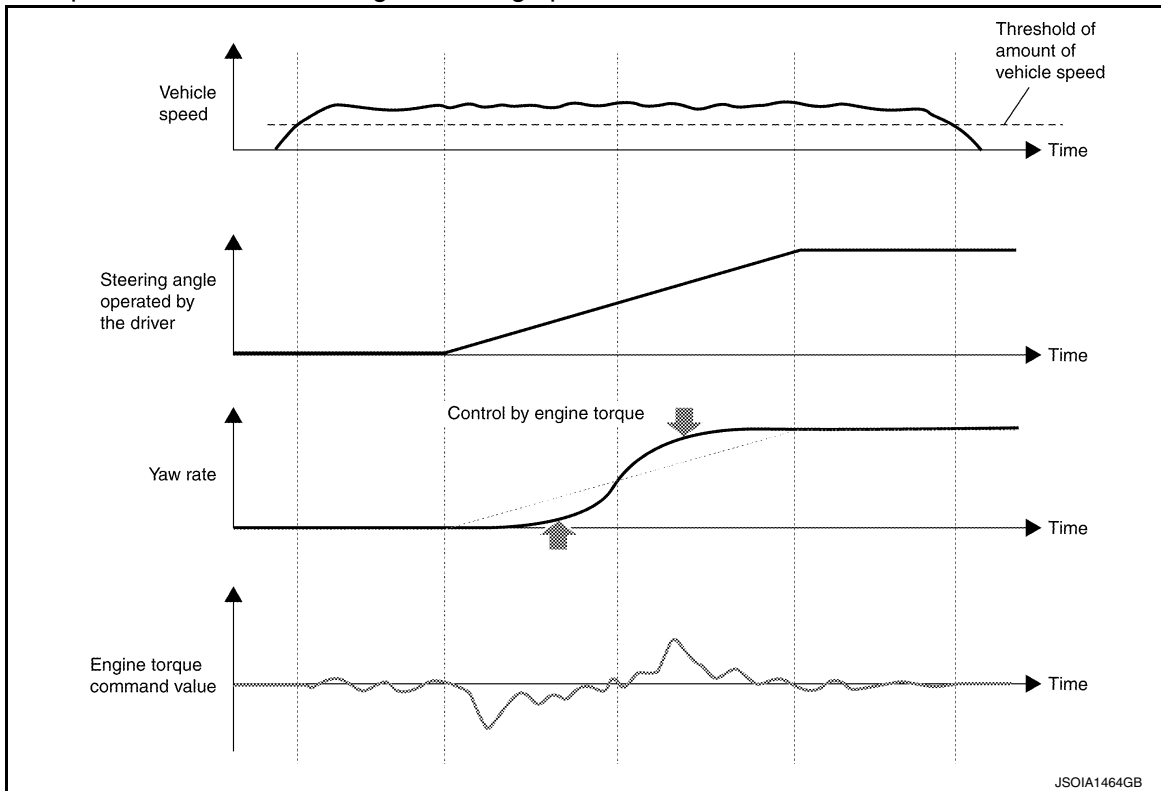

A  
B  
C  
D  
E  
F  
G  
H

## BRAKING CONTROL

- When driving on an uneven road surface, mainly the rotation speed information of each wheel is computed by the chassis control module to estimate vertical G and a command is transmitted to the ABS actuator and electric unit (control unit).
- The ABS actuator and electric unit (control unit) controls brake fluid pressure (brake force) according to the command from the chassis control module.
- By controlling the brake fluid pressure (brake force), behavior of the vehicle in the vertical direction decreases, and riding comfort is improved.

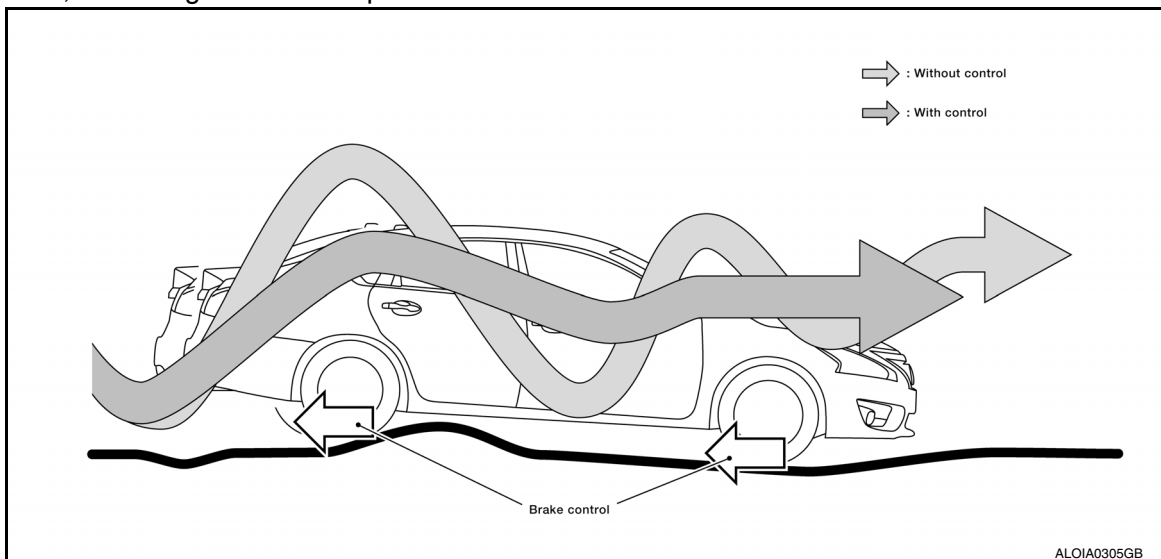

I  
J  
K  
L  
M  
N  
DAS  
P

# SYSTEM

< SYSTEM DESCRIPTION >

[CHASSIS CONTROL]

- Brake fluid pressure (brake force) is controlled according to driving conditions.

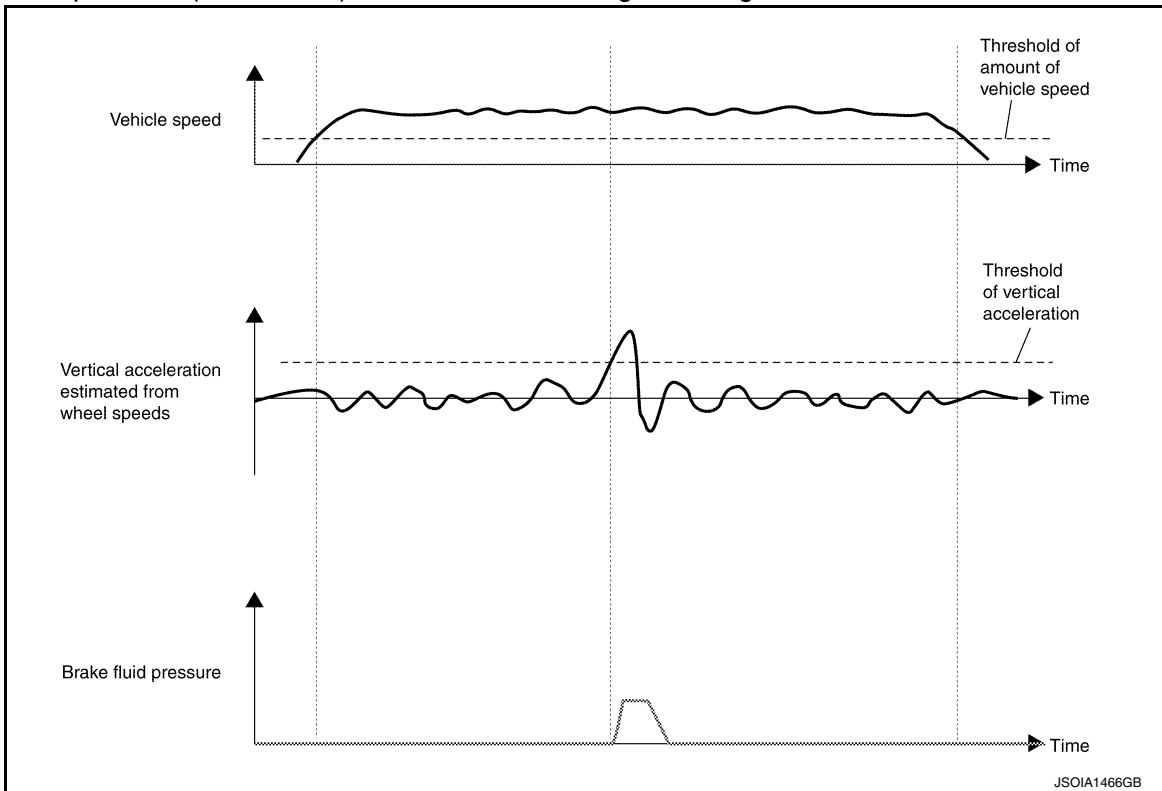

## SYSTEM DIAGRAM

### NOTE:

TCM is applied to CVT models.

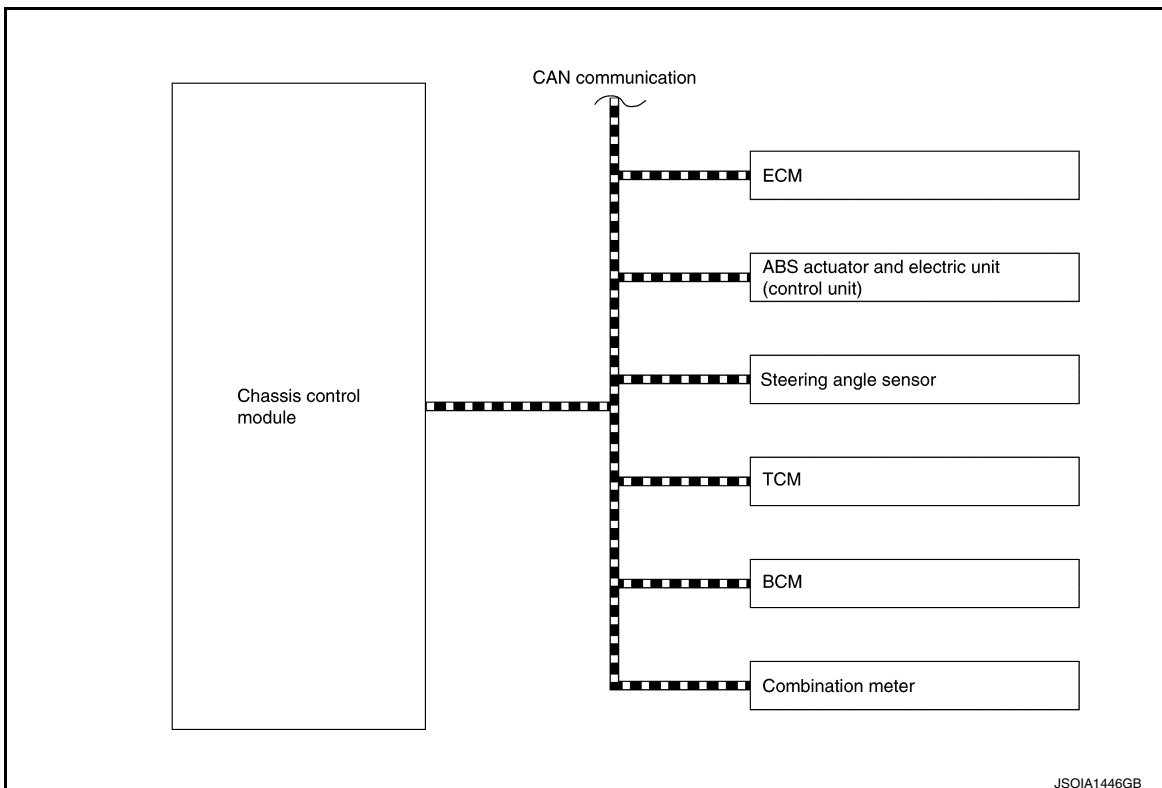

## INPUT SIGNAL AND OUTPUT SIGNAL

Major signal transmission between each unit via communication lines is shown in the following table:

# SYSTEM

< SYSTEM DESCRIPTION >

[CHASSIS CONTROL]

Component parts	Signal description	A
ECM	Transmits the following signals to chassis control module via CAN communication: <ul style="list-style-type: none"> <li>• Accelerator pedal position signal</li> <li>• Request drive torque signal</li> <li>• Request drive torque status signal</li> <li>• Engine speed signal</li> </ul>	B
ABS actuator and electric unit (control unit)	Transmits the following signals to chassis control module via CAN communication: <ul style="list-style-type: none"> <li>• Front LH wheel speed signal</li> <li>• Front RH wheel speed signal</li> <li>• Rear LH wheel speed signal</li> <li>• Rear RH wheel speed signal</li> <li>• ABS operation signal</li> <li>• TCS operation signal</li> <li>• VDC operation signal</li> <li>• Vehicle speed signal</li> <li>• Decel G signal</li> <li>• Side G signal</li> <li>• VDC OFF switch signal</li> <li>• Brake fluid pressure signal</li> <li>• VDC accept permission signal</li> </ul> Receives the active ride control signal from chassis control module via CAN communication.	C D E
BCM	Transmits the stop lamp switch signal to chassis control module via CAN communication.	F
IPDM E/R	Transmits the ignition switch ON signal to chassis control module via CAN communication.	G
TCM	Transmits the following signals to chassis control module via CAN communication: <ul style="list-style-type: none"> <li>• Current gear position signal</li> <li>• Input speed signal</li> </ul>	H
Combination meter	Receives the chassis control malfunction display request signal from chassis control module via CAN communication.	I
Steering angle sensor	Transmits the steering angle sensor signal to chassis control module via CAN communication.	J

DAS

P

## HANDLING PRECAUTION

### Precautions for Chassis Control (Engine Brake, Active Ride, and Active Trace)

INFOID:000000012271687

#### CHASSIS CONTROL

- Chassis Control will not provide all the necessary controls to replace driver intervention. It is not designed to prevent loss of control. It is the driver's responsibility to stay alert, drive safely, keep the vehicle in the traveling lane, and be in control of vehicle at all times.
- Chassis Control is primarily intended for use on well-developed freeways or highways. It may not perform satisfactorily in certain roads, weather or driving conditions.
- Using Chassis Control under some conditions of road, corner or severe weather could lead to an unexpected system operation. In such conditions, driver needs to correct the vehicle's direction with driver's steering operation to avoid accidents.
- When Chassis Control is operating, avoid excessive or sudden steering maneuvers. Otherwise, you could lose control of the vehicle.
- Engine Brake Control is designed to enhance braking feel and traceability at corners.
- Active Ride Control is designed to enhance handling and drive comfort.
- Active Trace Control is designed to enhance traceability at corners and smooth vehicle movement for more confident driving.
- Chassis Control may not function properly under the following conditions:
  - During bad weather (rain, fog, snow, wind, etc.).
  - When driving on slippery roads, such as on ice or snow, etc.
  - When driving on winding or uneven roads.
  - When driving with a tire that is not within normal tire conditions (for example, tire wear, low tire pressure, installation of spare tire, tire chains, non-standard wheels).
  - When the vehicle is equipped with non-original steering parts or suspension parts.
- The functions of Chassis Control may or may not operate properly under the following conditions:
  - On roads covered with water, dirt or snow, etc.
  - On roads where there are sharp curves.

# DIAGNOSIS SYSTEM (CHASSIS CONTROL MODULE)

< SYSTEM DESCRIPTION >

[CHASSIS CONTROL]

## DIAGNOSIS SYSTEM (CHASSIS CONTROL MODULE)

### CONSULT Function

INFOID:000000012271688

#### APPLICATION ITEM

CONSULT can display each diagnostic item using the diagnostic test modes as follows.

Diagnosis mode	Function description
Self Diagnostic Result	Self diagnostic result and freeze frame data can be read and erased quickly.*1
Data Monitor	Displays real-time input/output data of chassis control module.
ECU identification	Displays chassis control module part number.
Active Test	Enables an operational check of a load by transmitting a driving signal from the chassis control module.
Re/programming, Configuration	<ul style="list-style-type: none"><li>• Read and save the vehicle specification (TYPE ID).</li><li>• Write the vehicle specification (TYPE ID) when replacing chassis control module.</li></ul>

\*1: The following diagnosis information is erased by erasing:

- DTC
- Freeze Frame Data (FFD)

#### ECU IDENTIFICATION

Chassis control module part number can be read.

#### SELF DIAGNOSTIC RESULT

Refer to [DAS-210, "DTC Index"](#).

When "CRNT" is displayed on "Self diagnostic result".

- The system is presently malfunctioning.

When "PAST" is displayed on "Self diagnostic result".

- System malfunction in the past was detected, but the system is presently normal.

#### Freeze Frame Data (FFD)

When DTC is detected, a vehicle state shown below is recorded and displayed on CONSULT.

Item name	Indication/Unit	Display item
Odometer/Trip meter	km	Total mileage (odometer value) of the moment a particular DTC is detected is displayed.
DTC LOCAL CODE	—	DTC code is displayed but not used.
CAN DIAG PERMIS CONDITION	Off / On	Displays CAN network diagnosis status.
BRAKE SWITCH 1	Off / On	Displays brake switch operating status (Off: close / On: open).
BRAKE SWITCH 2	Off / On	Displays brake switch operating status (Off: open / On: close).
ABS	NORMAL / ABNOR	Displays ABS function status.
TCS	NORMAL / ABNOR	Displays TCS function status.
VDC	NORMAL / ABNOR	Displays VDC function status.
VEHICLE SPEED	km/h	Displays the vehicle speed.
FR WHEEL SPEED	rpm	Displays the rotational speed of front RH tire.
FL WHEEL SPEED	rpm	Displays the rotational speed of front LH tire.
RR WHEEL SPEED	rpm	Displays the rotational speed of rear RH tire.
RL WHEEL SPEED	rpm	Displays the rotational speed of rear LH tire.
STEERING ANG SENSOR	deg	Displays the steering angle from the steering angle sensor.
SIDE G SENSOR	G	Displays the side G.
DECEL G SENSOR	G	Displays the decel G.
YAW RATE SENSOR	deg/s	Displays the yaw rate.

A

B

C

D

E

F

G

H

I

J

K

L

M

N

DAS

P

# DIAGNOSIS SYSTEM (CHASSIS CONTROL MODULE)

< SYSTEM DESCRIPTION >

[CHASSIS CONTROL]

Item name	Indication/Unit	Display item
THRTL OPENING	%	Displays the electric throttle position.
SHIFT POSITION	Off / P / R / N / D (A) / S / L / B / 1 – 6 / M 1 – M 8 / A 1 – A 6	Displayed but not used.
PRESS SENSOR	bar	Displays the brake fluid pressure.

## DATA MONITOR

### NOTE:

The following table includes information (items) inapplicable to this vehicle. For information (items) applicable to this vehicle, refer to CONSULT display items.

Item [Unit]	Description
IGN VOLT [V]	Displays the ignition power supply voltage.
CONTROL MODULE MALF [Off / On]	Displays chassis control module malfunction.
CAN DIAG STATUS [Off / On]	Displays CAN network diagnosis status.
VEHICLE SPEED [km/m]	Displays the vehicle speed.
FR WHEEL SPEED [rpm]	Displays the rotational speed of front RH tire.
FL WHEEL SPEED [rpm]	Displays the rotational speed of front LH tire.
RR WHEEL SPEED [rpm]	Displays the rotational speed of rear RH tire.
RL WHEEL SPEED [rpm]	Displays the rotational speed of rear LH tire.
STEERING ANG SENSOR [deg]	Displays the steering angle from the steering angle sensor.
DECEL G SENSOR [G]	Displays the decel G.
SIDE G SENSOR [G]	Displays the side G.
YAW RATE SENSOR [deg/s]	Displays the yaw rate.
ACCELE PEDAL POSITION [%]	Displays the accelerator pedal position.
THROTTLE CONTROL [NORMAL / INCORR / PREV / IN-POSSI]	Displays the electric throttle status.
SHIFT POSITION [Off / P / R / N / D (A) / S / L / B / 1–6 / M 1 – M 8 / A 1 – A 6]	Displayed but not used.
BRAKE SWITCH 2 [Off / On]	Displays brake switch operating status (Off: close / On: open).
BRAKE SWITCH 1 [Off / On]	Displays brake switch operating status (Off: open / On: close).
PRESS SENSOR [bar]	Displays the brake fluid pressure.
ABS [NORMAL / ABNOR]	Displays ABS function status.
ABS MALF [NORMAL / ABNOR]	Displays ABS function status.
EBD [NORMAL / ABNOR]	Displays EBD function status.
TCS [NORMAL / ABNOR]	Displays TCS function status.
TCS MALF [NORMAL / ABNOR]	Displays TCS function status.
VDC [NORMAL / ABNOR]	Displays VDC function status.
VDC MALF [NORMAL / ABNOR]	Displays VDC function status.
VDC OFF SWITCH [Off / On]	Displays VDC OFF switch status.
DRV TRQ CTRL MODE [INITIAL / NORMAL / STOP 1 / STOP 2 / LIMIT 1 / PROHIBI]	Displays the status of correction to slightly increase/decrease the drive torque.
DRV TRQ CTRL PERMIS 1 [NO PER / PERMIS]	Displays the permission status (basic requirement) of correction to slightly increase/decrease drive torque.
DRV TRQ CTRL PERMIS 2 [NO PER / PERMIS]	Displays the permission status (system requirement) of correction to slightly increase/decrease drive torque.
DRV TRQ CTRL STOP [REQ / NO REQ]	Displays the stop request status of correction to slightly increase/decrease drive torque.

# DIAGNOSIS SYSTEM (CHASSIS CONTROL MODULE)

< SYSTEM DESCRIPTION >

[CHASSIS CONTROL]

Item [Unit]	Description
DRV TRQ CTRL PROHIBIT [REQ / NO REQ]	Displays the prohibition request status of correction to slightly increase/decrease drive torque.
AEB [Off / On]	Displays the Active Engine Brake (corner) function operating status
ATC 1 [Off / On]	Displays active trace control function operating status.
ATC 2 [Off / On]	Displays active trace control function operating status.
ATC 3 [Off / On]	Displays active trace control function operating status.
ATC 4 [Off / On]	Displays active trace control function operating status.
ATC 5 [Off / On]	Displays active trace control function operating status.
ATC SETTING [Off / On]	Displays active trace control status.
AEB CVT PERMIT [Off / On]	Displays the CVT authorized state for active engine brake.
AEB STATUS [Off / On]	Displays the active engine brake status.
AEB COMMAND 1 [0.0000]	Displays the relative command value of active engine brake.
AEB COMMAND 2 [0.0000]	Displays absolute command value of active engine brake.
AEB SLIP RATE [%]	Displays slip ratio of active engine brake.
AEB SETTING [Off / On]	Displays active engine brake control status.

## ACTIVE TEST

The active test is used to determine and identify details of a malfunction, based on self-diagnosis test results and data obtained in the Data Monitor. In response to instructions from CONSULT instead of those from chassis control module on the vehicle, a drive signal is sent to the actuator to check its operation.

### CAUTION:

- **Never perform ACTIVE TEST while driving the vehicle.**
- **Always bleed air from brake system before active test.**
- **Never perform active test when system is malfunctioning.**

### NOTE:

- When active test is performed while depressing the brake pedal, the brake pedal depressing stroke may change. This is not a malfunction.
- During an active test, sometimes a chassis control warning is displayed and the master warning lamp illuminates on the information display in the combination meter; however, this is not a malfunction.

Test item	Operation	Description
BRAKE ACTUATOR 1 MODE 1	Start	Controls brake fluid pressure.
BRAKE ACTUATOR 1 MODE 2	Start	Controls brake fluid pressure.
BRAKE ACTUATOR 1 MODE 3	Start	Controls brake fluid pressure.
BRAKE ACTUATOR 2 MODE 1	Start	Controls brake fluid pressure.
BRAKE ACTUATOR 2 MODE 2	Start	Controls brake fluid pressure.
BRAKE ACTUATOR 2 MODE 3	Start	Controls brake fluid pressure.
BRAKE ACTUATOR 3 MODE 1	Start	Controls brake fluid pressure.
BRAKE ACTUATOR 3 MODE 2	Start	Controls brake fluid pressure.
BRAKE ACTUATOR 3 MODE 3	Start	Controls brake fluid pressure.
MASTER WARNING ACTIVE	On	If touching "On" with the master warning lamp not illuminated, the master warning lamp illuminates. It stops in approximately 1 minute.
	Off	The master warning lamp turns OFF (vehicle in normal state).

## RE/PROGRAMMING, CONFIGURATION

Configuration includes the following functions.

# DIAGNOSIS SYSTEM (CHASSIS CONTROL MODULE)

< SYSTEM DESCRIPTION >

[CHASSIS CONTROL]

Function		Description
Read/Write Configuration	Before replacing ECU	Allows the reading of vehicle specification (Type ID) written in chassis control module to store the specification in CONSULT.
	After replacing ECU	Allows the writing of vehicle information (Type ID) stored in CONSULT into the chassis control module.
Manual Configuration		Allows the writing of vehicle specification (Type ID) into the chassis control module by hand.

**CAUTION:**

Use “Manual Configuration” only when “TYPE ID” of Chassis Control Module cannot be read.



# CHASSIS CONTROL MODULE

< ECU DIAGNOSIS INFORMATION >

[CHASSIS CONTROL]

## ECU DIAGNOSIS INFORMATION

### CHASSIS CONTROL MODULE

#### Reference Value

INFOID:0000000012271689

#### CONSULT DATA MONITOR STANDARD VALUE

**NOTE:**

The following table includes information (items) inapplicable to this vehicle. For information (items) applicable to this vehicle, refer to CONSULT display items.

Monitor item	Condition	Reference values in normal operation
IGN VOLT	Ignition switch ON.	10 – 16 V
CONTROL MODULE MALF	When chassis control module is normal.	Off
	When chassis control module malfunction is detected.	On
CAN DIAG STATUS	When diagnosis of CAN communication malfunction is detected.	Off
	When diagnosis of CAN communication is normal.	On
VEHICLE SPEED	Vehicle stopped.	0 mph (0 km/h)
	Driving*	Almost same reading as speedometer (within ± 10%)
FR WHEEL SPEED	Vehicle stopped.	0 rpm
	Driving*	Increases according to vehicle speed
FL WHEEL SPEED	Vehicle stopped.	0 rpm
	Driving*	Increases according to vehicle speed
RR WHEEL SPEED	Vehicle stopped.	0 rpm
	Driving*	Increases according to vehicle speed
RL WHEEL SPEED	Vehicle stopped.	0 rpm
	Driving*	Increases according to vehicle speed
STEERING ANG SENSOR	When driving straight.	0±3.5 deg.
	When steering wheel is steered to RH by 90°.	Approx. +90 deg.
	When steering wheel is steered to LH by 90°.	Approx. -90 deg.
DECEL G SENSOR	Vehicle stopped.	Approx. 0 G
	During acceleration.	Positive value
	During deceleration.	Negative value.
SIDE G SENSOR	Vehicle stopped.	Approx. 0 G
	When right turn.	Negative value
	When left turn.	Positive value
YAW RATE SENSOR	Vehicle stopped.	Approx. 0 deg/s
	When right turn.	Negative value
	When left turn.	Positive value
ACCELE PEDAL POSITION	When accelerator pedal is released.	0%
	When accelerator pedal is depressed.	0 – 100%

A  
B  
C  
D  
E  
F  
G  
H  
I  
J  
K  
L  
M  
N  
P

DAS

# CHASSIS CONTROL MODULE

< ECU DIAGNOSIS INFORMATION >

[CHASSIS CONTROL]

Monitor item	Condition	Reference values in normal operation
THROTTLE CONTROL	When electric throttle control actuator is normal.	NORMAL
	When the electric throttle control actuator does not achieve the requirement (measured value is inaccurate).	INCORR
	When the electric throttle control actuator does not achieve the requirement (temporary prevention).	PREV
	When the electric throttle control actuator does not achieve the requirement (impossible).	IMPOSSI
SHIFT POSITION	Shift selector in any position.	Displayed but not used
BRAKE SWITCH 2	When brake pedal is not depressed.	Off
	When brake pedal is depressed.	On
BRAKE SWITCH 1	When brake pedal is depressed.	Off
	When brake pedal is not depressed.	On
PRESS SENSOR	When brake pedal is not depressed.	Approx. 0 bar
	When brake pedal is depressed.	0 – 255 bar
ABS	When ABS function is normal.	NORMAL
	When ABS function malfunction is detected.	ABNOR
ABS MALF	When ABS function is normal.	NORMAL
	When ABS function malfunction is detected.	ABNOR
EBD	When EBD function is normal.	NORMAL
	When EBD function malfunction is detected.	ABNOR
ACCELE PEDAL MALF	When accelerator pedal is normal.	NORMAL
	When accelerator pedal malfunction is detected.	ABNOR
TCS	When TCS function is normal.	NORMAL
	When TCS function malfunction is detected.	ABNOR
TCS MALF	When TCS function is normal.	NORMAL
	When TCS function malfunction is detected.	ABNOR
VDC	When VDC function is normal.	NORMAL
	When VDC function malfunction is detected.	ABNOR
VDC MALF	When VDC function is normal.	NORMAL
	When VDC function malfunction is detected.	ABNOR
VDC OFF SWITCH	When VDC OFF switch is OFF.	Off
	When VDC OFF switch is ON.	On
DRV TRQ CTRL MODE	When correction coefficients are initialized.	INITIAL
	When correction is executed.	NORMAL
	When correction is stopped (computing is impossible).	STOP 1
	When correction is stopped (computing is possible).	STOP 2
	When correction is limited.	LIMIT 1
	When correction is prohibited.	PROHIBI
DRV TRQ CTRL PERMIS 1	When correction is permitted (basic requirement).	PERMIS
	When correction is not permitted (basic requirement).	NO PER
DRV TRQ CTRL PERMIS 2	When correction is permitted (system requirement).	PERMIS
	When correction is not permitted (system requirement).	NO PER
DRV TRQ CTRL STOP	When correction is requested to stop.	REQ
	When correction is not requested to stop.	NO REQ

# CHASSIS CONTROL MODULE

< ECU DIAGNOSIS INFORMATION >

[CHASSIS CONTROL]

Monitor item	Condition	Reference values in normal operation
DRV TRQ CTRL PROHIBIT	When prohibition of correction is requested.	REQ
	When prohibition of correction is not requested.	NO REQ
AEB	When Active Engine Brake (corner) function is active.	On
	When Active Engine Brake (corner) function is inactive.	Off
ATC 1	When active trace control function is inactive.	Off
	When active trace control function is active.	On
ATC 2	When active trace control function is inactive.	Off
	When active trace control function is active.	On
ATC 3	When active trace control function is inactive.	Off
	When active trace control function is active.	On
ATC 4	When active trace control function is inactive.	Off
	When active trace control function is active.	On
ATC 5	When active trace control function is inactive.	Off
	When active trace control function is active.	On
AEB CVT PERMIT	When transaxle control is authorized.	On
	When transaxle control is not authorized.	Off
AEB STATUS	When active engine brake function is ON.	On
	When active engine brake function is OFF.	Off
AEB COMMAND 1	When active engine brake function is inactive.	0 – 0.1023 G
	When active engine brake function is active.	0 G
AEB COMMAND 2	Displayed but not used.	—
AEB SLIP RATE	When slip ratio of active engine brake function is inactive.	0%
	When slip ratio of active engine brake function is active.	0 – 100%
ATC SETTING	When active trace control function is ON.	On
	When active trace control function is OFF.	Off
AEB SETTING	When active engine brake function is ON.	On
	When active engine brake function is OFF.	Off

\*: Check tire pressure under normal conditions.

## TERMINAL LAYOUT

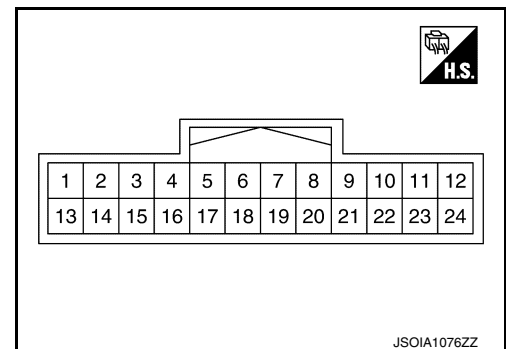

## PHYSICAL VALUES

A  
B  
C  
D  
E  
F  
G  
H  
I  
J  
K  
L  
M  
N  
DAS  
P

# CHASSIS CONTROL MODULE

< ECU DIAGNOSIS INFORMATION >

[CHASSIS CONTROL]

Terminal No. (Wire color)		Description		Condition		Value (Approx.)
+	-	Signal name	Input/Output			
3 (P)	Ground	CAN low	—	—	—	—
4 (L)		CAN high	—	—	—	—
8 (Y)		ITS CAN low	—	—	—	—
10 (BG)		IGN	Input	Ignition switch ON		6.4 – 16 V
11 (L)		ITS CAN high	—	—	—	—
12 (B)		Ground	—	Ignition switch ON		0 V

## Fail-Safe (Chassis Control Module)

INFOID:0000000012271690

When a malfunction occurs in the chassis control module, the master warning lamp turns ON and an interrupt is displayed on the information display of the combination meter.

DTC	Vehicle condition
C1B92-00	The following functions are suspended: <ul style="list-style-type: none"> <li>• Active Trace Control</li> <li>• Active Ride Control</li> <li>• Active Engine Brake</li> </ul>
C1B93-00	The following functions are suspended: <ul style="list-style-type: none"> <li>• Active Trace Control</li> <li>• Active Ride Control (engine)</li> <li>• Active Engine Brake</li> </ul>
C1B94-00	The following functions are suspended: <ul style="list-style-type: none"> <li>• Active Trace Control</li> <li>• Active Ride Control (engine)</li> </ul>
C1B95-00	The following functions are suspended: <ul style="list-style-type: none"> <li>• Active Trace Control</li> <li>• Active Ride Control (brake)</li> </ul>
C1B99-00	The following functions are suspended: <ul style="list-style-type: none"> <li>• Active Trace Control</li> <li>• Active Ride Control</li> <li>• Active Engine Brake</li> </ul>
C1BA0-00	The following functions are suspended: <ul style="list-style-type: none"> <li>• Active Trace Control</li> <li>• Active Ride Control (brake)</li> </ul>
C1BA2-00	The following functions are suspended: <ul style="list-style-type: none"> <li>• Active Trace Control</li> <li>• Active Ride Control (engine)</li> </ul>
C1BA5-00	Normal control
C1BAB-00	The following functions are suspended: <ul style="list-style-type: none"> <li>• Active Trace Control</li> <li>• Active Ride Control (engine)</li> </ul>
C1BB2-00	The following functions are suspended: <ul style="list-style-type: none"> <li>• Active Trace Control</li> <li>• Active Ride Control</li> <li>• Active Engine Brake</li> </ul>
C1BB3-00	
C1BB4-00	
C1BB5-00	
C1BB6-00	Normal control

# CHASSIS CONTROL MODULE

< ECU DIAGNOSIS INFORMATION >

[CHASSIS CONTROL]

DTC	Vehicle condition	
C1BB7-00		A
C1BB8-00	The following functions are suspended: • Active Trace Control • Active Ride Control • Active Engine Brake	B
C1BB9-00		
C1BBA-00		
C1BBB-00		
C1BBC-00	Normal control	C
C1BBD-00	The following functions are suspended: • Active Trace Control • Active Ride Control • Active Engine Brake	D
C1BC0-00	The following functions are suspended: • Active Trace Control • Active Ride Control	E
C1BC1-00		
C1BC2-00		
C1BC3-00		
C1BC4-00	The following function is suspended: • Active Ride Control (brake)	F
C1BC5-00	The following functions is suspended: • Active Trace Control	G
C1BC6-00	The following functions are suspended: • Active Trace Control • Active Ride Control (brake)	H
U1A34-00	The following functions are suspended: • Active Trace Control • Active Ride Control • Active Engine Brake	I
U1A35-00		
U1A36-00		
U1A39-00	Normal control	J
U1A3B-00	The following functions are suspended: • Active Trace Control • Active Ride Control (brake) • Active Engine Brake	K
U1A42-00	The following functions are suspended: • Active Trace Control • Active Ride Control (engine)	L
U1A43-00		
U1A48-00	The following functions are suspended: • Active Trace Control • Active Ride Control • Active Engine Brake	M
U1A4A-00		
U1A4B-00		
U1A4E-00	The following function is suspended: • Active Ride Control	N

## DTC Inspection Priority Chart

INFOID:0000000012271691

When multiple DTCs are displayed simultaneously, check them one by one according to the following priority list.

DAS

P

# CHASSIS CONTROL MODULE

< ECU DIAGNOSIS INFORMATION >

[CHASSIS CONTROL]

Priority	Detected item (DTC)
1	<ul style="list-style-type: none"> <li>U1000-00 CAN COMM CIRCUIT</li> </ul>
2	<ul style="list-style-type: none"> <li>U1A34-00 BRAKE CONTROL COMM</li> <li>U1A35-00 BRAKE CONTROL COMM</li> <li>U1A36-00 BCM/IPDM COMM</li> <li>U1A39-00 COMBINATION METER COMM</li> <li>U1A3B-00 TCM COMM</li> <li>U1A3F-00 AV COMM</li> <li>U1A42-00 STEERING ANGLE SENSOR COMM</li> <li>U1A43-00 STEERING ANGLE SENSOR COMM</li> <li>U1A48-00 ECM/HPCM COMM</li> <li>U1A4A-00 CONTROL MODULE (CAN)</li> <li>U1A4B-00 CONTROL MODULE (CAN)</li> <li>U1A4E-00 ECM/HPCM COMM</li> </ul>
3	<ul style="list-style-type: none"> <li>C1BBD-00 VARIANT CODING</li> </ul>
4	<ul style="list-style-type: none"> <li>C1B92-00 BRAKE CONTROL SYSTEM</li> <li>C1B93-00 ENGINE/HEV SYSTEM</li> <li>C1B94-00 TM SYSTEM</li> <li>C1BA0-00 ADAS/CHASSIS CTRL BRAKE SYS</li> <li>C1BA2-00 STEERING ANGLE SENSOR</li> <li>C1BA5-00 ADAS/CHASSIS CTRL ENGINE SYS</li> <li>C1BAB-00 STOP LAMP SW</li> <li>C1BC0-00 FR WHEEL SENSOR</li> <li>C1BC1-00 FL WHEEL SENSOR</li> <li>C1BC2-00 RR WHEEL SENSOR</li> <li>C1BC3-00 RL WHEEL SENSOR</li> <li>C1BC4-00 DECEL G SENSOR</li> <li>C1BC5-00 SIDE G SENSOR</li> <li>C1BC6-00 PRESSURE SENSOR</li> </ul>
5	<ul style="list-style-type: none"> <li>C1BB5-00 IGN POWER SUPPLY</li> <li>C1BB6-00 IGN POWER SUPPLY</li> </ul>
6	<ul style="list-style-type: none"> <li>C1B95-00 CONTROL MODULE</li> <li>C1B99-00 CONTROL MODULE</li> <li>C1BB2-00 CONTROL MODULE</li> <li>C1BB3-00 CONTROL MODULE</li> <li>C1BB4-00 CONTROL MODULE</li> <li>C1BB7-00 CONTROL MODULE</li> <li>C1BB8-00 CONTROL MODULE</li> <li>C1BB9-00 CONTROL MODULE</li> <li>C1BBA-00 CONTROL MODULE</li> <li>C1BBB-00 CONTROL MODULE</li> <li>C1BBC-00 CONTROL MODULE</li> </ul>

## DTC Index

INFOID:000000012271692

DTC	Display item	Refer to
C1B92-00	BRAKE CONTROL SYSTEM	<a href="#">DAS-220, "DTC Description"</a>
C1B93-00	ENGINE/HEV SYSTEM	<a href="#">DAS-222, "DTC Description"</a>
C1B94-00	TM SYSTEM	<a href="#">DAS-224, "DTC Description"</a>
C1B95-00	CONTROL MODULE	<a href="#">DAS-226, "DTC Description"</a>
C1B99-00	CONTROL MODULE	<a href="#">DAS-227, "DTC Description"</a>
C1BA0-00	ADAS/CHASSIS CTRL BRAKE SYS	<a href="#">DAS-228, "DTC Description"</a>
C1BA2-00	STEERING ANGLE SENSOR	<a href="#">DAS-230, "DTC Description"</a>
C1BA5-00	ADAS/CHASSIS CTRL ENGINE SYS	<a href="#">DAS-232, "DTC Description"</a>
C1BAB-00	STOP LAMP SW	<a href="#">DAS-234, "DTC Description"</a>
C1BB2-00	CONTROL MODULE	<a href="#">DAS-236, "DTC Description"</a>

# CHASSIS CONTROL MODULE

< ECU DIAGNOSIS INFORMATION >

[CHASSIS CONTROL]

DTC	Display item	Refer to
C1BB3-00	CONTROL MODULE	<a href="#">DAS-237, "DTC Description"</a>
C1BB4-00	CONTROL MODULE	<a href="#">DAS-238, "DTC Description"</a>
C1BB5-00	IGN POWER SUPPLY	<a href="#">DAS-239, "DTC Description"</a>
C1BB6-00	IGN POWER SUPPLY	<a href="#">DAS-241, "DTC Description"</a>
C1BB7-00	CONTROL MODULE	<a href="#">DAS-243, "DTC Description"</a>
C1BB8-00	CONTROL MODULE	<a href="#">DAS-244, "DTC Description"</a>
C1BB9-00	CONTROL MODULE	<a href="#">DAS-245, "DTC Description"</a>
C1BBA-00	CONTROL MODULE	<a href="#">DAS-246, "DTC Description"</a>
C1BBB-00	CONTROL MODULE	<a href="#">DAS-247, "DTC Description"</a>
C1BBC-00	CONTROL MODULE	<a href="#">DAS-248, "DTC Description"</a>
C1BBD-00	VARIANT CODING	<a href="#">DAS-249, "DTC Description"</a>
C1BC0-00	FR WHEEL SENSOR	<a href="#">DAS-250, "DTC Description"</a>
C1BC1-00	FL WHEEL SENSOR	<a href="#">DAS-252, "DTC Description"</a>
C1BC2-00	RR WHEEL SENSOR	<a href="#">DAS-254, "DTC Description"</a>
C1BC3-00	RL WHEEL SENSOR	<a href="#">DAS-256, "DTC Description"</a>
C1BC4-00	DECEL G SENSOR	<a href="#">DAS-258, "DTC Description"</a>
C1BC5-00	SIDE G SENSOR	<a href="#">DAS-260, "DTC Description"</a>
C1BC6-00	PRESSURE SENSOR	<a href="#">DAS-262, "DTC Description"</a>
U1000-00	CAN COMMUNICATION	<a href="#">DAS-264, "DTC Logic"</a>
U1A34-00	BRAKE CONTROL COMM	<a href="#">DAS-265, "DTC Description"</a>
U1A35-00	BRAKE CONTROL COMM	<a href="#">DAS-267, "DTC Description"</a>
U1A36-00	BCM/IPDM COMM	<a href="#">DAS-269, "DTC Description"</a>
U1A39-00	COMBINATION METER COMM	<a href="#">DAS-271, "DTC Description"</a>
U1A3B-00	TCM COMM	<a href="#">DAS-273, "DTC Description"</a>
U1A42-00	STEERING ANGLE SENSOR COMM	<a href="#">DAS-275, "DTC Description"</a>
U1A43-00	STEERING ANGLE SENSOR COMM	<a href="#">DAS-277, "DTC Description"</a>
U1A48-00	ECM/HPCM COMM	<a href="#">DAS-279, "DTC Description"</a>
U1A4A-00	CONTROL MODULE (CAN)	<a href="#">DAS-281, "DTC Description"</a>
U1A4B-00	CONTROL MODULE (CAN)	<a href="#">DAS-282, "DTC Description"</a>
U1A4E-00	ECM/HPCM COMM	<a href="#">DAS-283, "DTC Description"</a>

A  
B  
C  
D  
E  
F  
G  
H  
I  
J  
K  
L  
M  
N  
P

DAS

# WIRING DIAGRAM

## CHASSIS CONTROL

### Wiring Diagram

INFOID:0000000012271693

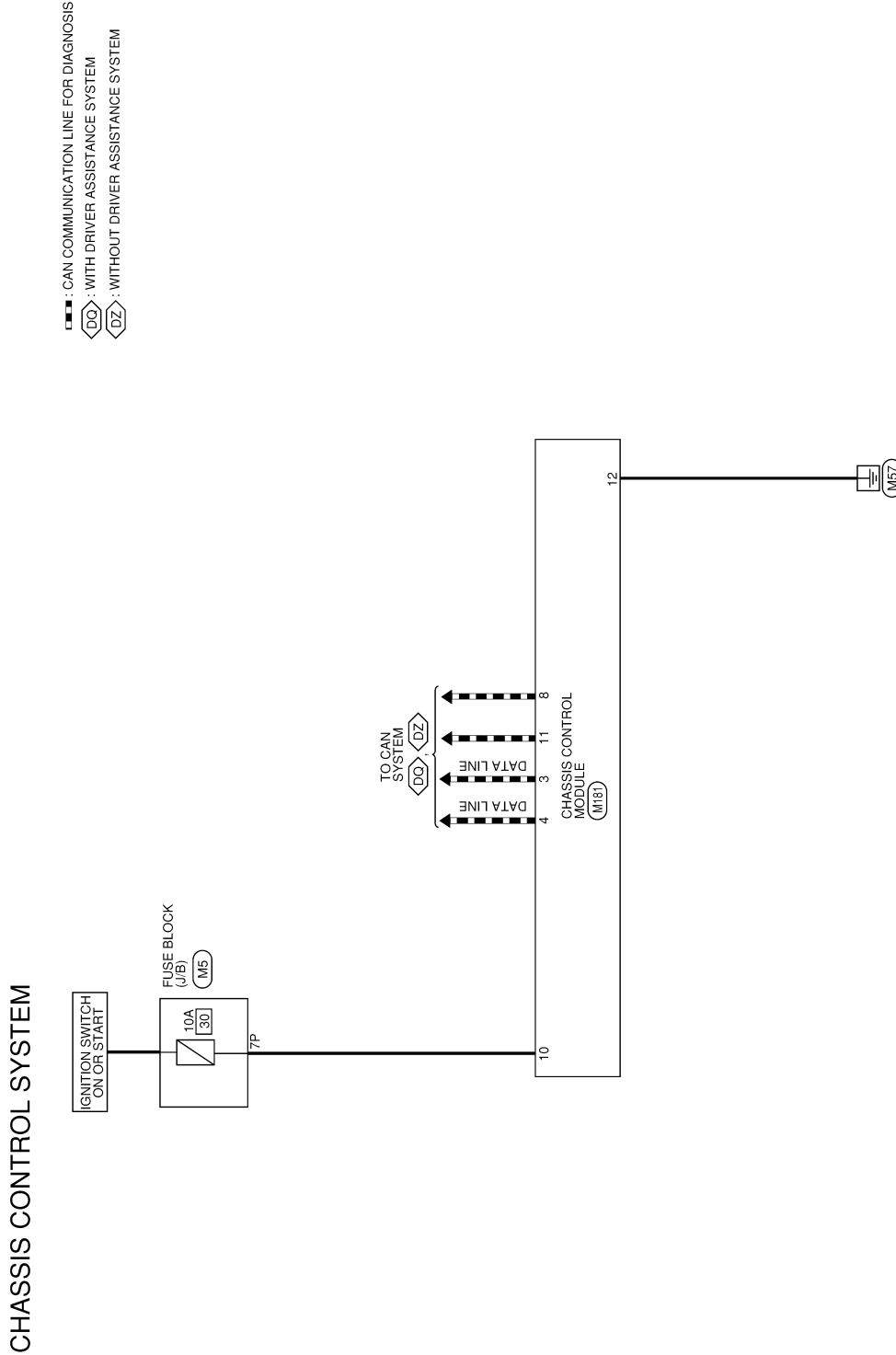

AAOWA0110GB



CHASSIS CONTROL SYSTEM CONNECTORS

22	-	-	-
23	-	-	-
24	-	-	-

Connector No.	M5
Connector Name	FUSE BLOCK (J/B)
Connector Type	NS16FW-CS
Connector Color	WHITE



Terminal No.	Color of Wire	Signal Name
7P	BG	-

Connector No.	M181
Connector Name	CHASSIS CONTROL MODULE
Connector Type	TH24FW-NH
Connector Color	WHITE

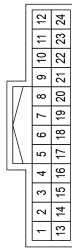

Terminal No.	Color of Wire	Signal Name
1	-	-
2	-	-
3	P	CAN-L
4	L	CAN-H
5	-	-
6	-	-
7	-	-
8	Y	ITS CAN-L
9	-	-
10	BG	IGN
11	L	ITS CAN-H
12	B	GND
13	-	-
14	-	-
15	-	-
16	-	-
17	-	-
18	-	-
19	-	-
20	-	-
21	-	-

AAOIA0377GB

A  
B  
C  
D  
E  
F  
G  
H  
I  
J  
K  
L  
M  
N  
P



# BASIC INSPECTION

## DIAGNOSIS AND REPAIR WORK FLOW

### Work Flow

INFOID:000000012271694

#### DETAILED FLOW

#### 1. INTERVIEW THE CUSTOMER

Clarify customer complaints before inspection. First of all, perform an interview utilizing [DAS-215, "Diagnostic Work Sheet"](#) and reproduce the symptom as well as fully understand it. Ask customer about his/her complaints carefully. Check symptoms by driving vehicle with customer if necessary.

**CAUTION:**

**Customers are not professional. Never guess easily like "maybe the customer means that..." or "maybe the customer mentions this symptom".**

&gt;&gt; GO TO 2.

#### 2. CHECK SYMPTOM

Reproduce the symptom that is indicated by the customer, based on the information from the customer obtained by the interview. Also, check that the symptom is not caused by fail-safe mode. Refer to [DAS-208, "Fail-Safe \(Chassis Control Module\)"](#).

**CAUTION:**

**When the symptom is caused by normal operation, fully inspect each portion and obtain the understanding of customer that the symptom is not caused by a malfunction.**

&gt;&gt; GO TO 3.

#### 3. PERFORM SELF-DIAGNOSIS

**CONSULT**

Perform "Self Diagnostic Result" mode of "CHASSIS CONTROL".

Is DTC detected?

YES >> Record or print "Self Diagnostic Result" and Freeze Frame Data (FFD). GO TO 4.

NO >> Inspection End.

#### 4. RECHECK THE SYMPTOM

**CONSULT**

Perform DTC confirmation procedure for the malfunctioning system.

**NOTE:**

If some DTCs are detected at the same time, determine the order for performing the diagnosis based on [DAS-209, "DTC Inspection Priority Chart"](#).

Is DTC detected?

YES >> GO TO 5.

NO >> Check harness and connectors based on the information obtained by the interview. Refer to [DAS-180, "Precautions for Harness Repair"](#).

#### 5. REPAIR OR REPLACE MALFUNCTIONING PARTS

1. Repair or replace malfunctioning parts.
2. Reconnect part or connector after repairing or replacing.
3. When DTC is detected, erase "Self Diagnostic Result" mode of "CHASSIS CONTROL".

&gt;&gt; GO TO 6.

#### 6. FINAL CHECK

**CONSULT**

1. Check the reference value of "CHASSIS CONTROL".
2. Recheck the symptom and check that the symptom is not reproduced in the same conditions.

# DIAGNOSIS AND REPAIR WORK FLOW

< BASIC INSPECTION >

[CHASSIS CONTROL]

Is the symptom reproduced?

YES >> GO TO 3.

NO >> Inspection End.

## Diagnostic Work Sheet

INFOID:0000000012271695

### Description

- In general, customers have their own criteria for a symptom. Therefore, it is important to understand the symptom and status well enough by interviewing the customer about the symptom carefully. To systemize all the information for the diagnosis, prepare the interview sheet referring to the interview points.
- In some cases, multiple conditions that appear simultaneously may cause a DTC to be detected.

### INTERVIEW SHEET SAMPLE

Interview sheet					
Customer name	MR/MS	Registration number		Initial year registration	
		Vehicle type		VIN	
Storage date		Engine, Trac-tion motor		Mileage	km ( Mile)
Symptom	<input type="checkbox"/> Does not operate ( ) function				
	<input type="checkbox"/> Warning lamp for ( ) turns ON.				
	<input type="checkbox"/> Noise <span style="float: right;"><input type="checkbox"/> Vibration</span>				
	<input type="checkbox"/> Other ( )				
First occurrence	<input type="checkbox"/> Recently <input type="checkbox"/> Other ( )				
Frequency of occurrence	<input type="checkbox"/> Always <input type="checkbox"/> Under a certain conditions of <input type="checkbox"/> Sometimes ( time(s)/day)				
Climate con-ditions	<input type="checkbox"/> Irrelevant				
	Weather	<input type="checkbox"/> Fine <input type="checkbox"/> Cloud <input type="checkbox"/> Rain <input type="checkbox"/> Snow <input type="checkbox"/> Others ( )			
	Temperature	<input type="checkbox"/> Hot <input type="checkbox"/> Warm <input type="checkbox"/> Cool <input type="checkbox"/> Cold <input type="checkbox"/> Temperature [Approx. °C ( °F)]			
	Relative humidity	<input type="checkbox"/> High <input type="checkbox"/> Moderate <input type="checkbox"/> Low			
Road conditions	<input type="checkbox"/> Urban area <input type="checkbox"/> Suburb area <input type="checkbox"/> Highway <input type="checkbox"/> Mountainous road (uphill or downhill) <input type="checkbox"/> Rough road				
Operating condition, etc.	<input type="checkbox"/> Irrelevant <input type="checkbox"/> When traction motor starts <input type="checkbox"/> During idling <input type="checkbox"/> During driving <input type="checkbox"/> During acceleration <input type="checkbox"/> At constant speed driving <input type="checkbox"/> During deceleration <input type="checkbox"/> During cornering (right curve or left curve) <input type="checkbox"/> When steering wheel is steered (to right or to left)				
Other conditions					

A  
B  
C  
D  
E  
F  
G  
H  
I  
J  
K  
L  
M  
N

DAS

P

# DIAGNOSIS AND REPAIR WORK FLOW

< BASIC INSPECTION >

[CHASSIS CONTROL]

## Interview sheet

Customer name	MR/MS	Registration number		Initial year registration	
		Vehicle type		VIN	
Storage date		Engine, Trac-tion motor		Mileage	km ( Mile)

Vehicle equipment

Memo

# ADDITIONAL SERVICE WHEN REPLACING CHASSIS CONTROL MODULE

< BASIC INSPECTION >

[CHASSIS CONTROL]

## ADDITIONAL SERVICE WHEN REPLACING CHASSIS CONTROL MODULE

### Description

INFOID:000000012271696

When replacing the chassis control module, configuration of the chassis control module is required. Refer to [DAS-218. "Work Procedure"](#).

A  
B  
C  
D  
E  
F  
G  
H  
I  
J  
K  
L  
M  
N  
P

DAS

# CONFIGURATION (CHASSIS CONTROL MODULE)

< BASIC INSPECTION >

[CHASSIS CONTROL]

## CONFIGURATION (CHASSIS CONTROL MODULE)

### Work Procedure

INFOID:000000012271697

#### **CAUTION:**

- Use “Manual Configuration” only when “TYPE ID” of the chassis control module cannot be read.
- After configuration, turn the ignition switch from OFF to ON and check that the chassis control warning to information display of combination meter displays OFF after staying illuminated for approximately two seconds.
- If an error occurs during configuration, start over from the beginning.

### 1. CHECKING TYPE ID (1)

Use FAST (service parts catalogue) to search the chassis control module of the applicable vehicle and find “Type ID”.

Is “Type ID” displayed?

YES >> Print out “Type ID” and GO TO 2.

NO >> “Configuration” is not required for the chassis control module. Replace in the usual manner. Refer to [DAS-290, "Removal and Installation"](#).

### 2. CHECKING TYPE ID (2)

ⓐCONSULT Configuration

1. Select “Before Replace ECU” of “Read/Write Configuration”.
2. Check that “Type ID” is displayed on the CONSULT screen.

Is “Type ID” displayed?

YES >> GO TO 3.

NO >> GO TO 7.

### 3. VERIFYING TYPE ID (1)

ⓐCONSULT Configuration

Compare a “Type ID” displayed on the CONSULT screen with the one searched by using FAST (service parts catalogue) to check that these “Type ID” agree with each other.

#### **NOTE:**

For the “Type ID” searched by using FAST (service parts catalog), use the last five digits of the “Type ID”.

>> GO TO 4.

### 4. SAVING TYPE ID

ⓐCONSULT Configuration

Save “Type ID” on CONSULT.

>> GO TO 5.

### 5. REPLACING CHASSIS CONTROL MODULE (1)

Replace the chassis control module. Refer to [DAS-290, "Removal and Installation"](#).

>> GO TO 6.

### 6. WRITING (AUTOMATIC WRITING)

ⓐCONSULT Configuration

1. Select “After Replace ECU” of “Re/programming, Configuration” or that of “Read / Write Configuration”.
2. Select the “Type ID” agreeing with the one stored on CONSULT and the one searched by using FAST (service parts catalogue) to write the “Type ID” into the chassis control module.

#### **NOTE:**

For the “Type ID” searched by using FAST (service parts catalog), use the last five digits of the “Type ID”.

>> GO TO 9.

### 7. REPLACING CHASSIS CONTROL MODULE (2)

# CONFIGURATION (CHASSIS CONTROL MODULE)

< BASIC INSPECTION >

[CHASSIS CONTROL]

Replace the chassis control module. Refer to [DAS-290. "Removal and Installation"](#).

>> GO TO 8.

## 8. WRITING (MANUAL WRITING)

 CONSULT Configuration

1. Select "Manual Configuration".
2. Select the "Type ID" searched by using FAST (service parts catalogue) to write the "Type ID" into the chassis control module.

**NOTE:**

For the "Type ID" searched by using FAST (service parts catalog), use the last five digits of the "Type ID".

>> GO TO 9.

## 9. VERIFYING TYPE ID (2)

Compare "Type ID" written into the chassis control module with the one searched by using FAST (service parts catalogue) to check that these "Type ID" agree with each other.

**NOTE:**

For the "Type ID" searched by using FAST (service parts catalog), use the last five digits of the "Type ID".

>> GO TO 10.

## 10. CHECKING CHASSIS CONTROL WARNING

1. Turn the ignition switch OFF.
2. Turn the ignition switch ON and check that the chassis control warning on information display of combination meter displays OFF after staying illuminated for approximately two seconds.

**CAUTION:**

**Never start the engine.**

Is the inspection result normal?

YES >> GO TO 11.

NO >> Perform the "Self Diagnostic Result" mode of "CHASSIS CONTROL". Refer to [DAS-201. "CONSULT Function"](#).

## 11. PERFORMING SUPPLEMENTARY WORK

1. Perform "Self Diagnostic Result" mode of all systems.
2. Erase "Self Diagnostic Result".

>> Work End.

A

B

C

D

E

F

G

H

I

J

K

L

M

N

DAS

P

# C1B92-00 BRAKE CONTROL SYSTEM

< DTC/CIRCUIT DIAGNOSIS >

[CHASSIS CONTROL]

## DTC/CIRCUIT DIAGNOSIS

### C1B92-00 BRAKE CONTROL SYSTEM

#### DTC Description

INFOID:0000000012271698

#### DTC DETECTION LOGIC

DTC No.	CONSULT screen terms (Trouble diagnosis content)	DTC detection condition	
C1B92-00	BRAKE CONTROL SYSTEM (Brake control system)	Diagnosis condition	When ignition switch is ON.
		Signal (terminal)	–
		Threshold	ABS actuator and electric unit (control unit) system malfunction
		Diagnosis delay time	–

#### POSSIBLE CAUSE

- ABS actuator and electric unit (control unit) system
- Chassis control module

#### FAIL-SAFE

The following functions are suspended:

- Active Ride Control function
- Active Trace Control function
- Active Engine Brake function

#### DTC CONFIRMATION PROCEDURE

##### 1. PRECONDITIONING

If “DTC CONFIRMATION PROCEDURE” has been previously conducted, always turn the ignition switch OFF and wait at least 10 seconds before conducting the next test.

>> GO TO 2.

##### 2. CHECK DTC DETECTION

###### CONSULT

1. Turn the ignition switch OFF to ON.

###### CAUTION:

**Be sure to wait 10 seconds after turning ignition switch OFF or ON.**

2. Select “Self Diagnostic Result” mode of “CHASSIS CONTROL”.

###### Is DTC “C1B92-00” detected?

YES >> Proceed to [DAS-220, "Diagnosis Procedure"](#).

NO-1 >> To check malfunction symptom before repair: Refer to [GI-41, "Intermittent Incident"](#).

NO-2 >> Confirmation after repair: Inspection End.

#### Diagnosis Procedure

INFOID:0000000012271699

##### 1. CHECK ABS ACTUATOR AND ELECTRIC UNIT (CONTROL UNIT)

###### CONSULT

Select “Self Diagnostic Result” mode of “ABS”.

###### Is DTC detected?

YES >> Check the DTC. Refer to [BRC-227, "DTC Index"](#).

NO >> GO TO 2.

##### 2. PERFORM SELF-DIAGNOSIS

###### CONSULT

1. Erase “Self Diagnostic Result” mode of “CHASSIS CONTROL”.
2. Turn the ignition switch OFF and wait for 10 seconds or more.



## C1B92-00 BRAKE CONTROL SYSTEM

< DTC/CIRCUIT DIAGNOSIS >

[CHASSIS CONTROL]

3. Turn the ignition switch ON.
4. Perform "All DTC Reading" mode.

Is DTC "C1B92-00", "U1000" or other DTC detected?

YES ("C1B92-00")>> Replace the chassis control module. Refer to [DAS-290, "Removal and Installation"](#).

YES ("U1000-00")>> Refer to [DAS-264, "Diagnosis Procedure"](#).

YES (other DTC) >> Check the DTC.

NO >> Inspection End.

A  
B  
C  
D  
E  
F  
G  
H  
I  
J  
K  
L  
M  
N  
P

DAS

## C1B93-00 ENGINE SYSTEM

### DTC Description

INFOID:000000012271700

### DTC DETECTION LOGIC

DTC No.	CONSULT screen terms (Trouble diagnosis content)	DTC detection condition	
C1B93-00	ENGINE SYSTEM (Engine system)	Diagnosis condition	When ignition switch is ON.
		Signal (terminal)	-
		Threshold	ECM system malfunction
		Diagnosis delay time	-

### POSSIBLE CAUSE

- Engine system
- ECM
- Chassis control module

### FAIL-SAFE

The following functions are suspended:

- Active Ride Control (engine) function
- Active Trace Control function
- Active Engine Brake function

### DTC CONFIRMATION PROCEDURE

#### 1. PRECONDITIONING

If "DTC CONFIRMATION PROCEDURE" has been previously conducted, always turn the ignition switch OFF and wait at least 10 seconds before conducting the next test.

>> GO TO 2.

#### 2. CHECK DTC DETECTION

##### ⓐ CONSULT

1. Turn the ignition switch OFF to ON.

**CAUTION:**

**Be sure to wait 10 seconds after turning ignition switch OFF or ON.**

2. Select "Self Diagnostic Result" mode of "CHASSIS CONTROL".

Is DTC "C1B93-00" detected?

- YES >> Proceed to [DAS-222, "Diagnosis Procedure"](#).
- NO-1 >> To check malfunction symptom before repair: Refer to [GI-41, "Intermittent Incident"](#).
- NO-2 >> Confirmation after repair: Inspection End.

### Diagnosis Procedure

INFOID:000000012271701

#### 1. CHECK ECM SYSTEM

##### ⓐ CONSULT

Select "Self Diagnostic Result" mode of "ENGINE".

Is DTC detected?

- YES >> Check the DTC. Refer to [EC-107, "DTC Index"](#).
- NO >> GO TO 2.

#### 2. PERFORM SELF-DIAGNOSIS

##### ⓐ CONSULT

1. Erase "Self Diagnostic Result" mode of "CHASSIS CONTROL".
2. Turn the ignition switch OFF and wait for 10 seconds or more.
3. Turn the ignition switch ON.

## C1B93-00 ENGINE SYSTEM

< DTC/CIRCUIT DIAGNOSIS >

[CHASSIS CONTROL]

4. Select "All DTC Reading" mode.

Is DTC "C1B93-00", "U1000" or other DTC detected?

YES ("C1B93-00")>> Replace the chassis control module. Refer to [DAS-290. "Removal and Installation"](#).

YES ("U1000-00")>> Refer to [DAS-264. "Diagnosis Procedure"](#).

YES (other DTC)>> Check the DTC.

NO >> Inspection End.

A

B

C

D

E

F

G

H

I

J

K

L

M

N

DAS

P

# C1B94-00 TRANSMISSION SYSTEM

< DTC/CIRCUIT DIAGNOSIS >

[CHASSIS CONTROL]

## C1B94-00 TRANSMISSION SYSTEM

### DTC Description

INFOID:000000012271702

### DTC DETECTION LOGIC

DTC No.	CONSULT screen terms (Trouble diagnosis content)	DTC detection condition	
C1B94-00	TM SYSTEM (Transmission system)	Diagnosis condition	When ignition switch is ON.
		Signal (terminal)	–
		Threshold	Transmission system malfunction
		Diagnosis delay time	–

### POSSIBLE CAUSE

- Transmission system
- TCM
- Chassis control module

### FAIL-SAFE

The following functions are suspended:

- Active Ride Control (engine) function
- Active Trace Control function

### DTC CONFIRMATION PROCEDURE

#### 1. PRECONDITIONING

If "DTC CONFIRMATION PROCEDURE" has been previously conducted, always turn the ignition switch OFF and wait at least 10 seconds before conducting the next test.

>> GO TO 2.

#### 2. CHECK DTC DETECTION

##### ⓐ CONSULT

1. Turn the ignition switch OFF to ON.

##### **CAUTION:**

**Be sure to wait 10 seconds after turning ignition switch OFF or ON.**

2. Select "Self Diagnostic Result" mode of "CHASSIS CONTROL".

Is DTC "C1B94-00" detected?

- YES >> Proceed to [DAS-224, "Diagnosis Procedure"](#).
- NO-1 >> To check malfunction symptom before repair: Refer to [GI-41, "Intermittent Incident"](#).
- NO-2 >> Confirmation after repair: Inspection End.

### Diagnosis Procedure

INFOID:000000012271703

#### 1. CHECK TRANSMISSION SYSTEM

##### ⓐ CONSULT

Select "Self Diagnostic Result" mode of "TRANSMISSION".

Is DTC detected?

- YES >> Check the DTC. Refer to [TM-58, "DTC Index"](#).
- NO >> GO TO 2.

#### 2. PERFORM SELF-DIAGNOSIS

##### ⓐ CONSULT

1. Erase "Self Diagnostic Result" mode of "CHASSIS CONTROL".
2. Turn the ignition switch OFF and wait for 10 seconds or more.
3. Turn the ignition switch ON.
4. Select "All DTC Reading" mode.

# C1B94-00 TRANSMISSION SYSTEM

[CHASSIS CONTROL]

< DTC/CIRCUIT DIAGNOSIS >

Is DTC "C1B94-00", "U1000-00" or other DTC detected?

YES ("C1B94-00")>> Replace the chassis control module. Refer to [DAS-290, "Removal and Installation"](#).

YES ("U1000-00")>> Refer to [DAS-264, "Diagnosis Procedure"](#).

YES (other DTC)>> Check the DTC.

NO >> Inspection End.

A

B

C

D

E

F

G

H

I

J

K

L

M

N

DAS

P

## C1B95-00 CONTROL MODULE

### DTC Description

INFOID:0000000012271704

### DTC DETECTION LOGIC

DTC No.	CONSULT screen terms (Trouble diagnosis content)	DTC detection condition	
C1B95-00	CONTROL MODULE (Control module)	Diagnosis condition	When ignition switch is ON.
		Signal (terminal)	-
		Threshold	Chassis control module malfunction
		Diagnosis delay time	-

### POSSIBLE CAUSE

Chassis control module

### FAIL-SAFE

The following functions are suspended:

- Active Trace Control function
- Active Ride Control (brake) function

### DTC CONFIRMATION PROCEDURE

#### 1. PRECONDITIONING

If "DTC CONFIRMATION PROCEDURE" has been previously conducted, always turn the ignition switch OFF and wait at least 10 seconds before conducting the next test.

>> GO TO 2.

#### 2. CHECK DTC DETECTION

##### Ⓟ CONSULT

1. Turn the ignition switch OFF to ON.

**CAUTION:**

**Be sure to wait 10 seconds after turning ignition switch OFF or ON.**

2. Select "Self Diagnostic Result" mode of "CHASSIS CONTROL".

Is DTC "C1B95-00" detected?

- YES >> Proceed to [DAS-226. "Diagnosis Procedure"](#).
- NO-1 >> To check malfunction symptom before repair: Refer to [GI-41. "Intermittent Incident"](#).
- NO-2 >> Confirmation after repair: Inspection End.

### Diagnosis Procedure

INFOID:0000000012271705

#### 1. PERFORM SELF-DIAGNOSIS

##### Ⓟ CONSULT

1. Erase "Self Diagnostic Result" mode of "CHASSIS CONTROL".
2. Turn the ignition switch OFF and wait for 10 seconds or more.
3. Turn the ignition switch ON.
4. Select "Self Diagnostic Result" mode of "CHASSIS CONTROL".

Is DTC "C1B95-00" detected?

- YES >> Replace the chassis control module. Refer to [DAS-290. "Removal and Installation"](#).
- NO >> Inspection End.

C1B99-00 CONTROL MODULE

DTC Description

INFOID:000000012271706

DTC DETECTION LOGIC

DTC No.	CONSULT screen terms (Trouble diagnosis content)	DTC detection condition	
C1B99-00	CONTROL MODULE (Control module)	Diagnosis condition	When ignition switch is ON.
		Signal (terminal)	-
		Threshold	Chassis control module malfunction
		Diagnosis delay time	-

POSSIBLE CAUSE

Chassis control module

FAIL-SAFE

The following functions are suspended:

- Active Ride Control function
- Active Trace Control function
- Active Engine Brake function

DTC CONFIRMATION PROCEDURE

1. PRECONDITIONING

If "DTC CONFIRMATION PROCEDURE" has been previously conducted, always turn the ignition switch OFF and wait at least 10 seconds before conducting the next test.

>> GO TO 2.

2. CHECK DTC DETECTION

ⓂCONSULT

1. Turn the ignition switch OFF to ON.

**CAUTION:**

**Be sure to wait 10 seconds after turning ignition switch OFF or ON.**

2. Select "Self Diagnostic Result" mode of "CHASSIS CONTROL".

Is DTC "C1B99-00" detected?

- YES >> Proceed to [DAS-227, "Diagnosis Procedure"](#).
- NO-1 >> To check malfunction symptom before repair: Refer to [GI-41, "Intermittent Incident"](#).
- NO-2 >> Confirmation after repair: Inspection End.

Diagnosis Procedure

INFOID:000000012271707

1. PERFORM SELF-DIAGNOSIS

ⓂCONSULT

1. Erase "Self Diagnostic Result" mode of "CHASSIS CONTROL".
2. Turn the ignition switch OFF and wait for 10 seconds or more.
3. Turn the ignition switch ON.
4. Select "Self Diagnostic Result" mode of "CHASSIS CONTROL".

Is DTC "C1B99-00" detected?

- YES >> Replace the chassis control module. Refer to [DAS-290, "Removal and Installation"](#).
- NO >> Inspection End.

DAS

# C1BA0-00 ADAS/CHASSIS CONTROL BRAKE SYSTEM

< DTC/CIRCUIT DIAGNOSIS >

[CHASSIS CONTROL]

## C1BA0-00 ADAS/CHASSIS CONTROL BRAKE SYSTEM

### DTC Description

INFOID:000000012271708

### DTC DETECTION LOGIC

DTC No.	CONSULT screen terms (Trouble diagnosis content)	DTC detection condition	
C1BA0-00	ADAS/CHASSIS CTRL BRAKE SYS (ADAS/chassis control brake sys- tem)	Diagnosis condition	When ignition switch is ON.
		Signal (terminal)	–
		Threshold	An invalid signal is received from ABS actu- ator and electric unit (control unit)
		Diagnosis delay time	–

### POSSIBLE CAUSE

- ABS actuator and electric unit (control unit)
- Chassis control module

### FAIL-SAFE

The following functions are suspended:

- Active Trace Control function
- Active Ride Control (brake) function

### DTC CONFIRMATION PROCEDURE

#### 1.PRECONDITIONING

If “DTC CONFIRMATION PROCEDURE” has been previously conducted, always turn the ignition switch OFF and wait at least 10 seconds before conducting the next test.

>> GO TO 2.

#### 2.CHECK DTC DETECTION

##### CONSULT

1. Turn the ignition switch OFF to ON.

##### CAUTION:

**Be sure to wait 10 seconds after turning ignition switch OFF or ON.**

2. Select “Self Diagnostic Result” mode of “CHASSIS CONTROL”.

Is DTC “C1BA0-00” and/or “C1BA7-00” detected?

YES (“C1BA0-00”) >> Proceed to [DAS-228, "Diagnosis Procedure"](#).

YES (“C1BA0-00”) and “C1BA7-00”) >> Select “Self Diagnostic Result” mode of “ICC/ADAS”.

NO-1 >> To check malfunction symptom before repair: Refer to [GI-41, "Intermittent Incident"](#).

NO-2 >> Confirmation after repair: Inspection End.

### Diagnosis Procedure

INFOID:000000012271709

#### 1.CHECK ABS ACTUATOR AND ELECTRIC UNIT (CONTROL UNIT) SYSTEM

##### CONSULT

Select “Self Diagnostic Result” mode of “ABS”.

Is DTC detected?

YES >> Check the DTC. Refer to [BRC-227, "DTC Index"](#).

NO >> GO TO 2.

#### 2.PERFORM SELF-DIAGNOSIS

##### CONSULT

1. Erase “Self Diagnostic Result” mode of “CHASSIS CONTROL”.
2. Turn the ignition switch OFF and wait for 10 seconds or more.
3. Turn the ignition switch ON.
4. Select “All DTC Reading” mode.



# C1BA0-00 ADAS/CHASSIS CONTROL BRAKE SYSTEM

< DTC/CIRCUIT DIAGNOSIS >

[CHASSIS CONTROL]

Is DTC "C1BA0-00", "U1000-00" or other DTC detected?

YES ("C1BA0-00")>> Replace the chassis control module. Refer to [DAS-290, "Removal and Installation"](#).

YES ("U1000-00")>> Refer to [DAS-264, "Diagnosis Procedure"](#).

YES (other DTC)>> Check the DTC.

NO >> Inspection End.

A  
B  
C  
D  
E  
F  
G  
H  
I  
J  
K  
L  
M  
N  
P

DAS

# C1BA2-00 STEERING ANGLE SENSOR

< DTC/CIRCUIT DIAGNOSIS >

[CHASSIS CONTROL]

## C1BA2-00 STEERING ANGLE SENSOR

### DTC Description

INFOID:000000012271710

### DTC DETECTION LOGIC

DTC No.	CONSULT screen terms (Trouble diagnosis content)	DTC detection condition	
C1BA2-00	STEERING ANGLE SENSOR (Steering angle sensor)	Diagnosis condition	When ignition switch is ON.
		Signal (terminal)	—
		Threshold	When a malfunction is detected in steering angle sensor
		Diagnosis delay time	—

### POSSIBLE CAUSE

- Steering angle sensor
- Chassis control module

### FAIL-SAFE

The following functions are suspended:

- Active Ride Control (engine) function
- Active Trace Control function

### DTC CONFIRMATION PROCEDURE

#### 1. PRECONDITIONING

If "DTC CONFIRMATION PROCEDURE" has been previously conducted, always turn the ignition switch OFF and wait at least 10 seconds before conducting the next test.

>> GO TO 2.

#### 2. CHECK DTC DETECTION

##### CONSULT

1. Turn the ignition switch OFF to ON.

##### CAUTION:

**Be sure to wait 10 seconds after turning ignition switch OFF or ON.**

2. Select "Self Diagnostic Result" mode of "CHASSIS CONTROL".

##### Is DTC "C1BA2-00" detected?

- YES >> Proceed to [DAS-230, "Diagnosis Procedure"](#).  
NO-1 >> To check malfunction symptom before repair: Refer to [GI-41, "Intermittent Incident"](#).  
NO-2 >> Confirmation after repair: Inspection End.

### Diagnosis Procedure

INFOID:000000012271711

#### 1. CHECK STEERING ANGLE SENSOR SYSTEM

##### CONSULT

Select "Self Diagnostic Result" mode of "ABS".

##### Is DTC detected?

- YES >> Check the DTC. Refer to [BRC-227, "DTC Index"](#).  
NO >> GO TO 2.

#### 2. PERFORM SELF-DIAGNOSIS

##### CONSULT

1. Erase "Self Diagnostic Result" mode of "CHASSIS CONTROL".
2. Turn the ignition switch OFF and wait for 10 seconds or more.
3. Turn the ignition switch ON.
4. Select "All DTC Reading" mode.

# C1BA2-00 STEERING ANGLE SENSOR

< DTC/CIRCUIT DIAGNOSIS >

[CHASSIS CONTROL]

Is DTC "C1BA2-00", "U1000-00" or other DTC detected?

YES ("C1BA2-00")>> Replace the chassis control module. Refer to [DAS-290, "Removal and Installation"](#).

YES ("U1000-00")>> Refer to [DAS-264, "Diagnosis Procedure"](#).

YES (other DTC)>> Check the DTC.

NO >> Inspection End.

A  
B  
C  
D  
E  
F  
G  
H  
I  
J  
K  
L  
M  
N  
P

DAS

# C1BA5-00 ADAS/CHASSIS CONTROL ENGINE SYSTEM

< DTC/CIRCUIT DIAGNOSIS >

[CHASSIS CONTROL]

## C1BA5-00 ADAS/CHASSIS CONTROL ENGINE SYSTEM

### DTC Description

INFOID:000000012271712

### DTC DETECTION LOGIC

DTC No.	CONSULT screen terms (Trouble diagnosis content)	DTC detection condition	
C1BA5-00	ADAS/CHASSIS CTRL ENGINE SYS (ADAS/chassis control engine system)	Diagnosis condition	When ignition switch is ON.
		Signal (terminal)	—
		Threshold	When receiving from ECM that the value of the engine system signal transmitted from the chassis control module to ECM is malfunctioning
		Diagnosis delay time	—

### POSSIBLE CAUSE

Chassis control module

### DTC CONFIRMATION PROCEDURE

#### 1. PRECONDITIONING

If “DTC CONFIRMATION PROCEDURE” has been previously conducted, always turn the ignition switch OFF and wait at least 10 seconds before conducting the next test.

>> GO TO 2.

#### 2. CHECK DTC DETECTION

##### ⓐ CONSULT

1. Turn the ignition switch OFF to ON.

##### **CAUTION:**

**Be sure to wait 10 seconds after turning ignition switch OFF or ON.**

2. Select “Self Diagnostic Result” mode of “CHASSIS CONTROL”.

Is DTC “C1BA5-00” detected?

YES >> Proceed to [DAS-232, "Diagnosis Procedure"](#).

NO-1 >> To check malfunction symptom before repair: Refer to [GI-41, "Intermittent Incident"](#).

NO-2 >> Confirmation after repair: Inspection End.

### Diagnosis Procedure

INFOID:000000012271713

#### 1. CHECK ADAS CONTROL UNIT SYSTEM

##### ⓐ CONSULT

Select “Self Diagnostic Result” mode of “ECM”.

Is DTC detected?

YES >> Check the DTC. Refer to [EC-107, "DTC Index"](#).

NO >> GO TO 2.

#### 2. PERFORM SELF-DIAGNOSIS

##### ⓐ CONSULT

1. Erase “Self Diagnostic Result” mode of “CHASSIS CONTROL”.

2. Turn the ignition switch OFF and wait for 10 seconds or more.

3. Turn the ignition switch ON.

4. Select “All DTC Reading” mode.

Is DTC “C1BA5-00”, “U1000-00” or other DTC detected?

YES (“C1BA5-00”) >> Replace the chassis control module. Refer to [DAS-290, "Removal and Installation"](#).

YES (“U1000-00”) >> Refer to [DAS-264, "Diagnosis Procedure"](#).

YES (other DTC) >> Check the DTC.

# C1BA5-00 ADAS/CHASSIS CONTROL ENGINE SYSTEM

< DTC/CIRCUIT DIAGNOSIS >

[CHASSIS CONTROL]

NO >> Inspection End.

A

B

C

D

E

F

G

H

I

J

K

L

M

N

DAS

P

# C1BAB-00 STOP LAMP SWITCH

< DTC/CIRCUIT DIAGNOSIS >

[CHASSIS CONTROL]

## C1BAB-00 STOP LAMP SWITCH

### DTC Description

INFOID:000000012271714

### DTC DETECTION LOGIC

DTC No.	CONSULT screen terms (Trouble diagnosis content)	DTC detection condition	
C1BAB-00	STOP LAMP SW (Stop lamp switch)	Diagnosis condition	When ignition switch is ON.
		Signal (terminal)	–
		Threshold	When a malfunction is detected in stop lamp switch system
		Diagnosis delay time	–

### POSSIBLE CAUSE

- Stop lamp switch
- BCM
- Chassis control module

### FAIL-SAFE

The following functions are suspended:

- Active Ride Control (engine) function
- Active Trace Control function

### DTC CONFIRMATION PROCEDURE

#### 1. PRECONDITIONING

If “DTC CONFIRMATION PROCEDURE” has been previously conducted, always turn the ignition switch OFF and wait at least 10 seconds before conducting the next test.

>> GO TO 2.

#### 2. CHECK DTC DETECTION

##### CONSULT

1. Turn the ignition switch OFF to ON.

##### CAUTION:

**Be sure to wait 10 seconds after turning ignition switch OFF or ON.**

2. Select “Self Diagnostic Result” mode of “CHASSIS CONTROL”.

##### Is DTC “C1BAB-00” detected?

- YES >> Proceed to [DAS-234, "Diagnosis Procedure"](#).
- NO-1 >> To check malfunction symptom before repair: Refer to [GI-41, "Intermittent Incident"](#).
- NO-2 >> Confirmation after repair: Inspection End.

### Diagnosis Procedure

INFOID:000000012271715

#### 1. CHECK STOP LAMP SWITCH SYSTEM

##### CONSULT

Select “Self Diagnostic Result” mode of “BCM”.

##### Is DTC detected?

- YES >> Check the DTC. Refer to [BCS-53, "DTC Index"](#).
- NO >> GO TO 2.

#### 2. PERFORM SELF-DIAGNOSIS

##### CONSULT

1. Erase “Self Diagnostic Result” mode of “CHASSIS CONTROL”.
2. Turn the ignition switch OFF and wait for 10 seconds or more.
3. Turn the ignition switch ON.
4. Select “All DTC Reading” mode.

## C1BAB-00 STOP LAMP SWITCH

< DTC/CIRCUIT DIAGNOSIS >

[CHASSIS CONTROL]

Is DTC "C1BAB-00", "U1000-00" or other DTC detected?

YES ("C1BAB-00")>> Replace the chassis control module. Refer to [DAS-290, "Removal and Installation"](#).

YES ("U1000-00")>> Refer to [DAS-264, "Diagnosis Procedure"](#).

YES (other DTC)>> Check the DTC.

NO >> Inspection End.

A

B

C

D

E

F

G

H

I

J

K

L

M

N

DAS

P

## C1BB2-00 CONTROL MODULE

### DTC Description

INFOID:000000012271716

### DTC DETECTION LOGIC

DTC No.	CONSULT screen terms (Trouble diagnosis content)	DTC detection condition	
C1BB2-00	CONTROL MODULE (Control module)	Diagnosis condition	When ignition switch is ON.
		Signal (terminal)	–
		Threshold	When a malfunction is detected in chassis control module
		Diagnosis delay time	–

### POSSIBLE CAUSE

Chassis control module

### FAIL-SAFE

The following functions are suspended:

- Active Trace Control function
- Active Ride Control function
- Active Engine Brake function

### DTC CONFIRMATION PROCEDURE

#### 1. PRECONDITIONING

If “DTC CONFIRMATION PROCEDURE” has been previously conducted, always turn the ignition switch OFF and wait at least 10 seconds before conducting the next test.

>> GO TO 2.

#### 2. CHECK DTC DETECTION

##### CONSULT

1. Turn the ignition switch OFF to ON.

**CAUTION:**

**Be sure to wait 10 seconds after turning ignition switch OFF or ON.**

2. Select “Self Diagnostic Result” mode of “CHASSIS CONTROL”.

##### Is DTC “C1BB2-00” detected?

YES >> Proceed to [DAS-236, "Diagnosis Procedure"](#).

NO-1 >> To check malfunction symptom before repair: Refer to [GI-41, "Intermittent Incident"](#).

NO-2 >> Confirmation after repair: Inspection End.

### Diagnosis Procedure

INFOID:000000012271717

#### 1. PERFORM SELF-DIAGNOSIS

##### CONSULT

1. Erase “Self Diagnostic Result” mode of “CHASSIS CONTROL”.
2. Turn the ignition switch OFF and wait for 10 seconds or more.
3. Turn the ignition switch ON.
4. Select “Self Diagnostic Result” mode of “CHASSIS CONTROL”.

##### Is DTC “C1BB2-00” detected?

YES >> Replace the chassis control module. Refer to [DAS-290, "Removal and Installation"](#).

NO >> Inspection End.



## C1BB3-00 CONTROL MODULE

### DTC Description

INFOID:000000012271718

### DTC DETECTION LOGIC

DTC No.	CONSULT screen terms (Trouble diagnosis content)	DTC detection condition	
C1BB3-00	CONTROL MODULE (Control module)	Diagnosis condition	When ignition switch is ON.
		Signal (terminal)	-
		Threshold	When a malfunction is detected in chassis control module
		Diagnosis delay time	-

### POSSIBLE CAUSE

Chassis control module

### FAIL-SAFE

The following functions are suspended:

- Active Trace Control function
- Active Ride Control function
- Active Engine Brake function

### DTC CONFIRMATION PROCEDURE

#### 1. PRECONDITIONING

If "DTC CONFIRMATION PROCEDURE" has been previously conducted, always turn the ignition switch OFF and wait at least 10 seconds before conducting the next test.

>> GO TO 2.

#### 2. CHECK DTC DETECTION

##### CONSULT

1. Turn the ignition switch OFF to ON.

**CAUTION:**

**Be sure to wait 10 seconds after turning ignition switch OFF or ON.**

2. Select "Self Diagnostic Result" mode of "CHASSIS CONTROL".

##### Is DTC "C1BB3-00" detected?

YES >> Proceed to [DAS-237. "Diagnosis Procedure"](#).

NO-1 >> To check malfunction symptom before repair: Refer to [Gl-41. "Intermittent Incident"](#).

NO-2 >> Confirmation after repair: Inspection End.

### Diagnosis Procedure

INFOID:000000012271719

#### 1. PERFORM SELF-DIAGNOSIS

##### CONSULT

1. Erase "Self Diagnostic Result" mode of "CHASSIS CONTROL".
2. Turn the ignition switch OFF and wait for 10 seconds or more.
3. Turn the ignition switch ON.
4. Select "Self Diagnostic Result" mode of "CHASSIS CONTROL".

##### Is DTC "C1BB3-00" detected?

YES >> Replace the chassis control module. Refer to [DAS-290. "Removal and Installation"](#).

NO >> Inspection End.

A  
B  
C  
D  
E  
F  
G  
H  
I  
J  
K  
L  
M  
N  
P

DAS

## C1BB4-00 CONTROL MODULE

### DTC Description

INFOID:000000012271720

### DTC DETECTION LOGIC

DTC No.	CONSULT screen terms (Trouble diagnosis content)	DTC detection condition	
C1BB4-00	CONTROL MODULE (Control module)	Diagnosis condition	When ignition switch is ON.
		Signal (terminal)	-
		Threshold	When a malfunction is detected in chassis control module
		Diagnosis delay time	-

### POSSIBLE CAUSE

Chassis control module

### FAIL-SAFE

The following functions are suspended:

- Active Trace Control function
- Active Ride Control function
- Active Engine Brake function

### DTC CONFIRMATION PROCEDURE

#### 1. PRECONDITIONING

If "DTC CONFIRMATION PROCEDURE" has been previously conducted, always turn the ignition switch OFF and wait at least 10 seconds before conducting the next test.

>> GO TO 2.

#### 2. CHECK DTC DETECTION

##### CONSULT

1. Turn the ignition switch OFF to ON.

**CAUTION:**

**Be sure to wait 10 seconds after turning ignition switch OFF or ON.**

2. Select "Self Diagnostic Result" mode of "CHASSIS CONTROL".

##### Is DTC "C1BB4-00" detected?

- YES >> Proceed to [DAS-238, "Diagnosis Procedure"](#).
- NO-1 >> To check malfunction symptom before repair: Refer to [GI-41, "Intermittent Incident"](#).
- NO-2 >> Confirmation after repair: Inspection End.

### Diagnosis Procedure

INFOID:000000012271721

#### 1. PERFORM SELF-DIAGNOSIS

##### CONSULT

1. Erase "Self Diagnostic Result" mode of "CHASSIS CONTROL".
2. Turn the ignition switch OFF and wait for 10 seconds or more.
3. Turn the ignition switch ON.
4. Select "Self Diagnostic Result" mode of "CHASSIS CONTROL".

##### Is DTC "C1BB4-00" detected?

- YES >> Replace the chassis control module. Refer to [DAS-290, "Removal and Installation"](#).
- NO >> Inspection End.

# C1BB5-00 IGNITION POWER SUPPLY

< DTC/CIRCUIT DIAGNOSIS >

[CHASSIS CONTROL]

## C1BB5-00 IGNITION POWER SUPPLY

### DTC Description

INFOID:000000012271722

### DTC DETECTION LOGIC

DTC No.	CONSULT screen terms (Trouble diagnosis content)	DTC detection condition	
		Diagnosis condition	When ignition switch is ON.
C1BB5-00	IGN POWER SUPPLY (Ignition power supply)	Signal (terminal)	–
		Threshold	Ignition power supply voltage: $6.4\text{ V} \geq$ ignition power supply voltage
		Diagnosis delay time	–

### POSSIBLE CAUSE

- Harness or connector
- Fuse
- Ignition power supply system
- Battery
- Chassis control module

### FAIL-SAFE

The following functions are suspended:

- Active Trace Control function
- Active Ride Control function
- Active Engine Brake function

### DTC CONFIRMATION PROCEDURE

#### 1. PRECONDITIONING

If “DTC CONFIRMATION PROCEDURE” has been previously conducted, always turn the ignition switch OFF and wait at least 10 seconds before conducting the next test.

>> GO TO 2.

#### 2. CHECK DTC DETECTION

##### CONSULT

1. Turn the ignition switch OFF to ON.

##### CAUTION:

**Be sure to wait 10 seconds after turning ignition switch OFF or ON.**

2. Select “Self Diagnostic Result” mode of “CHASSIS CONTROL”.

##### Is DTC “C1BB5-00” detected?

- YES >> Proceed to [DAS-239, "Diagnosis Procedure"](#).
- NO-1 >> To check malfunction symptom before repair: Refer to [GI-41, "Intermittent Incident"](#).
- NO-2 >> Confirmation after repair: Inspection End.

### Diagnosis Procedure

INFOID:000000012271723

DAS

Regarding Wiring Diagram information, refer to [DAS-212, "Wiring Diagram"](#).

#### 1. CHECK CONNECTOR

1. Turn the ignition switch OFF.
2. Disconnect chassis control module harness connector M181.
3. Check the connector for disconnection or looseness.
4. Check the terminals for damage or loose connection with harness connector.

##### Is the inspection result normal?

# C1BB5-00 IGNITION POWER SUPPLY

[CHASSIS CONTROL]

< DTC/CIRCUIT DIAGNOSIS >

- YES >> GO TO 2.  
NO >> Repair or replace error-detected parts and securely lock the harness connector. GO TO 2.

## 2.PERFORM SELF-DIAGNOSIS (1)

1. Connect chassis control module harness connector M181.
2. Select "Self Diagnostic Result" mode of "CHASSIS CONTROL".

Is DTC "C1BB5-00" detected?

- YES >> GO TO 3.  
NO >> Inspection End.

## 3.CHECK FUSE

Check that the following fuse is not blown.

Terminal	Signal name	Fuse No.
7P	Ignition power supply	30 (10 A)

Is the fuse blown?

- YES >> Replace the blown fuse after repairing the affected circuit.  
NO >> GO TO 2.

## 4.CHECK POWER SUPPLY CIRCUIT

1. Turn the ignition switch OFF.
2. Disconnect chassis control module harness connector M181.
3. Check the voltage between chassis control module harness connector M181 terminal 10 and ground.

Chassis control module		—	Voltage (Approx.)
Connector	Terminal		
M181	10	Ground	0 V

4. Turn the ignition switch ON.  
**CAUTION:**  
**Never start the engine.**
5. Check the voltage between chassis control module harness connector M181 terminal 10 and ground.

Chassis control module		—	Voltage (Approx.)
Connector	Terminal		
M181	10	Ground	6.4–16 V

Is the inspection result normal?

- YES >> GO TO 3.  
NO >> Repair or replace harness or connector.

## 5.CHECK CHASSIS CONTROL MODULE GROUND CIRCUIT

Check the continuity between chassis control module harness connector M181 terminal 12 and ground.

Chassis control module		—	Continuity
Connector	Terminal		
M181	12	Ground	Yes

Is the inspection result normal?

- YES >> Inspection End.  
NO >> Repair or replace harness or connector.

# C1BB6-00 IGNITION POWER SUPPLY

< DTC/CIRCUIT DIAGNOSIS >

[CHASSIS CONTROL]

## C1BB6-00 IGNITION POWER SUPPLY

### DTC Description

INFOID:000000012271724

### DTC DETECTION LOGIC

DTC No.	CONSULT screen terms (Trouble diagnosis content)	DTC detection condition	
C1BB6-00	IGNITION POWER SUPPLY (Ignition power supply)	Diagnosis condition	When ignition switch is ON.
		Signal (terminal)	–
		Threshold	Ignition power supply voltage: $16\text{ V} \leq$ ignition power supply voltage
		Diagnosis delay time	–

### POSSIBLE CAUSE

- Harness or connector
- Fuse
- Ignition power supply system
- Battery
- Chassis control module

### DTC CONFIRMATION PROCEDURE

#### 1. PRECONDITIONING

If "DTC CONFIRMATION PROCEDURE" has been previously conducted, always turn the ignition switch OFF and wait at least 10 seconds before conducting the next test.

>> GO TO 2.

#### 2. CHECK DTC DETECTION

##### CONSULT

1. Turn the ignition switch OFF to ON.

##### CAUTION:

**Be sure to wait 10 seconds after turning ignition switch OFF or ON.**

2. Select "Self Diagnostic Result" mode of "CHASSIS CONTROL".

Is DTC "C1BB6-00" detected?

YES >> Proceed to [DAS-241, "Diagnosis Procedure"](#).

NO-1 >> To check malfunction symptom before repair: Refer to [GI-41, "Intermittent Incident"](#).

NO-2 >> Confirmation after repair: Inspection End.

### Diagnosis Procedure

INFOID:000000012271725

Regarding Wiring Diagram information, refer to [DAS-212, "Wiring Diagram"](#).

#### 1. CHECK CONNECTOR

1. Turn the ignition switch OFF.
2. Disconnect chassis control module harness connector M181.
3. Check the connector for disconnection or looseness.
4. Check the pin terminals for damage or loose connection with harness connector.

Is the inspection result normal?

YES >> GO TO 2.

NO >> Repair or replace error-detected parts and securely lock the harness connector. GO TO 2.

#### 2. PERFORM SELF-DIAGNOSIS (1)

1. Connect chassis control module harness connector M181.

A

B

C

D

E

F

G

H

I

J

K

L

M

N

DAS

P

# C1BB6-00 IGNITION POWER SUPPLY

[CHASSIS CONTROL]

< DTC/CIRCUIT DIAGNOSIS >

2. Select "Self Diagnostic Result" mode of "CHASSIS CONTROL".

Is DTC "C1BB6-00" detected?

YES >> GO TO 3.

NO >> Inspection End.

## 3.CHECK FUSE

Check that the following fuse is not blown.

Terminal	Signal name	Fuse No.
7P	Ignition power supply	30 (10 A)

Is the fuse blown?

YES >> Replace the blown fuse after repairing the affected circuit.

NO >> GO TO 2.

## 4.CHECK POWER SUPPLY CIRCUIT

1. Turn the ignition switch OFF.

2. Disconnect chassis control module harness connector M181.

3. Check the voltage between chassis control module harness connector M181 terminal 10 and ground.

Chassis control module		—	Voltage (Approx.)
Connector	Terminal		
M181	10	Ground	0 V

4. Turn the ignition switch ON.

**CAUTION:**

**Never start the engine.**

5. Check the voltage between chassis control module harness connector M181 terminal 10 and ground.

Chassis control module		—	Voltage (Approx.)
Connector	Terminal		
M181	10	Ground	6.4–16 V

Is the inspection result normal?

YES >> GO TO 3.

NO >> Repair or replace harness or connector.

## 5.CHECK CHASSIS CONTROL MODULE GROUND CIRCUIT

Check the continuity between chassis control module harness connector M181 terminal 12 and ground.

Chassis control module		—	Continuity
Connector	Terminal		
M181	12	Ground	Yes

Is the inspection result normal?

YES >> Inspection End.

NO >> Repair or replace harness or connector.

## C1BB7-00 CONTROL MODULE

### DTC Description

INFOID:000000012271726

### DTC DETECTION LOGIC

DTC No.	CONSULT screen terms (Trouble diagnosis content)	DTC detection condition	
C1BB7-00	CONTROL MODULE (Control module)	Diagnosis condition	When ignition switch is ON.
		Signal (terminal)	-
		Threshold	When a malfunction is detected in chassis control module
		Diagnosis delay time	-

### POSSIBLE CAUSE

Chassis control module

### FAIL-SAFE

The following functions are suspended:

- Active Trace Control function
- Active Ride Control function
- Active Engine Brake function

### DTC CONFIRMATION PROCEDURE

#### 1. PRECONDITIONING

If "DTC CONFIRMATION PROCEDURE" has been previously conducted, always turn the ignition switch OFF and wait at least 10 seconds before conducting the next test.

>> GO TO 2.

#### 2. CHECK DTC DETECTION

##### CONSULT

1. Turn the ignition switch OFF to ON.

**CAUTION:**

**Be sure to wait 10 seconds after turning ignition switch OFF or ON.**

2. Select "Self Diagnostic Result" mode of "CHASSIS CONTROL".

##### Is DTC "C1BB7-00" detected?

YES >> Proceed to [DAS-243. "Diagnosis Procedure"](#).

NO-1 >> To check malfunction symptom before repair: Refer to [GI-41. "Intermittent Incident"](#).

NO-2 >> Confirmation after repair: Inspection End.

### Diagnosis Procedure

INFOID:000000012271727

#### 1. PERFORM SELF-DIAGNOSIS

##### CONSULT

1. Erase "Self Diagnostic Result" mode of "CHASSIS CONTROL".
2. Turn the ignition switch OFF and wait for 10 seconds or more.
3. Turn the ignition switch ON.
4. Select "Self Diagnostic Result" mode of "CHASSIS CONTROL".

##### Is DTC "C1BB7-00" detected?

YES >> Replace the chassis control module. Refer to [DAS-290. "Removal and Installation"](#).

NO >> Inspection End.

A  
B  
C  
D  
E  
F  
G  
H  
I  
J  
K  
L  
M  
N  
P



## C1BB8-00 CONTROL MODULE

### DTC Description

INFOID:000000012271728

### DTC DETECTION LOGIC

DTC No.	CONSULT screen terms (Trouble diagnosis content)	DTC detection condition	
C1BB8-00	CONTROL MODULE (Control module)	Diagnosis condition	When ignition switch is ON.
		Signal (terminal)	-
		Threshold	When a malfunction is detected in chassis control module
		Diagnosis delay time	-

### POSSIBLE CAUSE

Chassis control module

### FAIL-SAFE

The following functions are suspended:

- Active Trace Control function
- Active Ride Control function
- Active Engine Brake function

### DTC CONFIRMATION PROCEDURE

#### 1. PRECONDITIONING

If "DTC CONFIRMATION PROCEDURE" has been previously conducted, always turn the ignition switch OFF and wait at least 10 seconds before conducting the next test.

>> GO TO 2.

#### 2. CHECK DTC DETECTION

##### CONSULT

1. Turn the ignition switch OFF to ON.

**CAUTION:**

**Be sure to wait 10 seconds after turning ignition switch OFF or ON.**

2. Select "Self Diagnostic Result" mode of "CHASSIS CONTROL".

##### Is DTC "C1BB8-00" detected?

YES >> Proceed to [DAS-244, "Diagnosis Procedure"](#).

NO-1 >> To check malfunction symptom before repair: Refer to [GI-41, "Intermittent Incident"](#).

NO-2 >> Confirmation after repair: Inspection End.

### Diagnosis Procedure

INFOID:000000012271729

#### 1. PERFORM SELF-DIAGNOSIS

##### CONSULT

1. Erase "Self Diagnostic Result" mode of "CHASSIS CONTROL".
2. Turn the ignition switch OFF and wait for 10 seconds or more.
3. Turn the ignition switch ON.
4. Select "Self Diagnostic Result" mode of "CHASSIS CONTROL".

##### Is DTC "C1BB8-00" detected?

YES >> Replace the chassis control module. Refer to [DAS-290, "Removal and Installation"](#).

NO >> Inspection End.



## C1BB9-00 CONTROL MODULE

### DTC Description

INFOID:000000012271730

### DTC DETECTION LOGIC

DTC No.	CONSULT screen terms (Trouble diagnosis content)	DTC detection condition	
C1BB9-00	CONTROL MODULE (Control module)	Diagnosis condition	When ignition switch is ON.
		Signal (terminal)	-
		Threshold	When a malfunction is detected in chassis control module
		Diagnosis delay time	-

### POSSIBLE CAUSE

Chassis control module

### FAIL-SAFE

The following functions are suspended:

- Active Trace Control function
- Active Ride Control function
- Active Engine Brake function

### DTC CONFIRMATION PROCEDURE

#### 1. PRECONDITIONING

If "DTC CONFIRMATION PROCEDURE" has been previously conducted, always turn the ignition switch OFF and wait at least 10 seconds before conducting the next test.

>> GO TO 2.

#### 2. CHECK DTC DETECTION

##### CONSULT

1. Turn the ignition switch OFF to ON.

**CAUTION:**

**Be sure to wait 10 seconds after turning ignition switch OFF or ON.**

2. Select "Self Diagnostic Result" mode of "CHASSIS CONTROL".

##### Is DTC "C1BB9-00" detected?

YES >> Proceed to [DAS-245, "Diagnosis Procedure"](#).

NO-1 >> To check malfunction symptom before repair: Refer to [GI-41, "Intermittent Incident"](#).

NO-2 >> Confirmation after repair: Inspection End.

### Diagnosis Procedure

INFOID:000000012271731

#### 1. PERFORM SELF-DIAGNOSIS

##### CONSULT

1. Erase "Self Diagnostic Result" mode of "CHASSIS CONTROL".
2. Turn the ignition switch OFF and wait for 10 seconds or more.
3. Turn the ignition switch ON.
4. Select "Self Diagnostic Result" mode of "CHASSIS CONTROL".

##### Is DTC "C1BB9-00" detected?

YES >> Replace the chassis control module. Refer to [DAS-290, "Removal and Installation"](#).

NO >> Inspection End.

A  
B  
C  
D  
E  
F  
G  
H  
I  
J  
K  
L  
M  
N  
P



## C1BBA-00 CONTROL MODULE

### DTC Description

INFOID:000000012271732

### DTC DETECTION LOGIC

DTC No.	CONSULT screen terms (Trouble diagnosis content)	DTC detection condition	
C1BBA-00	CONTROL MODULE (Control module)	Diagnosis condition	When ignition switch is ON.
		Signal (terminal)	-
		Threshold	When a malfunction is detected in chassis control module
		Diagnosis delay time	-

### POSSIBLE CAUSE

Chassis control module

### FAIL-SAFE

The following functions are suspended:

- Active Trace Control function
- Active Ride Control function
- Active Engine Brake function

### DTC CONFIRMATION PROCEDURE

#### 1. PRECONDITIONING

If "DTC CONFIRMATION PROCEDURE" has been previously conducted, always turn the ignition switch OFF and wait at least 10 seconds before conducting the next test.

>> GO TO 2.

#### 2. CHECK DTC DETECTION

##### CONSULT

1. Turn the ignition switch OFF to ON.

**CAUTION:**

**Be sure to wait 10 seconds after turning ignition switch OFF or ON.**

2. Select "Self Diagnostic Result" mode of "CHASSIS CONTROL".

##### Is DTC "C1BBA-00" detected?

- YES >> Proceed to [DAS-246, "Diagnosis Procedure"](#).
- NO-1 >> To check malfunction symptom before repair: Refer to [GI-41, "Intermittent Incident"](#).
- NO-2 >> Confirmation after repair: Inspection End.

### Diagnosis Procedure

INFOID:000000012271733

#### 1. PERFORM SELF-DIAGNOSIS

##### CONSULT

1. Erase "Self Diagnostic Result" mode of "CHASSIS CONTROL".
2. Turn the ignition switch OFF and wait for 10 seconds or more.
3. Turn the ignition switch ON.
4. Select "Self Diagnostic Result" mode of "CHASSIS CONTROL".

##### Is DTC "C1BBA-00" detected?

- YES >> Replace the chassis control module. Refer to [DAS-290, "Removal and Installation"](#).
- NO >> Inspection End.

## C1BBB-00 CONTROL MODULE

### DTC Description

INFOID:000000012271734

### DTC DETECTION LOGIC

DTC No.	CONSULT screen terms (Trouble diagnosis content)	DTC detection condition	
C1BBB-00	CONTROL MODULE (Control module)	Diagnosis condition	When ignition switch is ON.
		Signal (terminal)	-
		Threshold	When a malfunction is detected in chassis control module
		Diagnosis delay time	-

### POSSIBLE CAUSE

Chassis control module

### FAIL-SAFE

The following functions are suspended:

- Active Trace Control function
- Active Ride Control function
- Active Engine Brake function

### DTC CONFIRMATION PROCEDURE

#### 1. PRECONDITIONING

If "DTC CONFIRMATION PROCEDURE" has been previously conducted, always turn the ignition switch OFF and wait at least 10 seconds before conducting the next test.

>> GO TO 2.

#### 2. CHECK DTC DETECTION

##### CONSULT

1. Turn the ignition switch OFF to ON.

**CAUTION:**

**Be sure to wait 10 seconds after turning ignition switch OFF or ON.**

2. Select "Self Diagnostic Result" mode of "CHASSIS CONTROL".

##### Is DTC "C1BBB-00" detected?

YES >> Proceed to [DAS-247. "Diagnosis Procedure"](#).

NO-1 >> To check malfunction symptom before repair: Refer to [GI-41. "Intermittent Incident"](#).

NO-2 >> Confirmation after repair: Inspection End.

### Diagnosis Procedure

INFOID:000000012271735

#### 1. PERFORM SELF-DIAGNOSIS

##### CONSULT

1. Erase "Self Diagnostic Result" mode of "CHASSIS CONTROL".
2. Turn the ignition switch OFF and wait for 10 seconds or more.
3. Turn the ignition switch ON.
4. Select "Self Diagnostic Result" mode of "CHASSIS CONTROL".

##### Is DTC "C1BBB-00" detected?

YES >> Replace the chassis control module. Refer to [DAS-290. "Removal and Installation"](#).

NO >> Inspection End.

A  
B  
C  
D  
E  
F  
G  
H  
I  
J  
K  
L  
M  
N  
P

DAS

## C1BBC-00 CONTROL MODULE

### DTC Description

INFOID:0000000012271736

### DTC DETECTION LOGIC

DTC No.	CONSULT screen terms (Trouble diagnosis content)	DTC detection condition	
C1BBC-00	CONTROL MODULE (Control module)	Diagnosis condition	When ignition switch is ON.
		Signal (terminal)	-
		Threshold	When a malfunction is detected in chassis control module
		Diagnosis delay time	-

### POSSIBLE CAUSE

Chassis control module

### DTC CONFIRMATION PROCEDURE

#### 1. PRECONDITIONING

If "DTC CONFIRMATION PROCEDURE" has been previously conducted, always turn the ignition switch OFF and wait at least 10 seconds before conducting the next test.

>> GO TO 2.

#### 2. CHECK DTC DETECTION

##### ⓐ CONSULT

1. Turn the ignition switch OFF to ON.

**CAUTION:**

**Be sure to wait 10 seconds after turning ignition switch OFF or ON.**

2. Select "Self Diagnostic Result" mode of "CHASSIS CONTROL".

##### Is DTC "C1BBC-00" detected?

- YES >> Proceed to [DAS-248. "Diagnosis Procedure"](#).
- NO-1 >> To check malfunction symptom before repair: Refer to [GI-41. "Intermittent Incident"](#).
- NO-2 >> Confirmation after repair: Inspection End.

### Diagnosis Procedure

INFOID:0000000012271737

#### 1. PERFORM SELF-DIAGNOSIS

##### ⓐ CONSULT

1. Erase "Self Diagnostic Result" mode of "CHASSIS CONTROL".
2. Turn the ignition switch OFF and wait for 10 seconds or more.
3. Turn the ignition switch ON.
4. Select "Self Diagnostic Result" mode of "CHASSIS CONTROL".

##### Is DTC "C1BBC-00" detected?

- YES >> Replace the chassis control module. Refer to [DAS-290. "Removal and Installation"](#).
- NO >> Inspection End.

C1BBD-00 VARIANT CODING

DTC Description

INFOID:000000012271738

DTC DETECTION LOGIC

DTC No.	CONSULT screen terms (Trouble diagnosis content)	DTC detection condition	
		Diagnosis condition	When ignition switch is ON.
C1BBD-00	VARIANT CODING (Variant coding)	Signal (terminal)	-
		Threshold	When variant coding is incomplete
		Diagnosis delay time	-

POSSIBLE CAUSE

Chassis control module

FAIL-SAFE

The following functions are suspended:

- Active Trace Control function
- Active Ride Control function
- Active Engine Brake function

DTC CONFIRMATION PROCEDURE

1. PRECONDITIONING

If "DTC CONFIRMATION PROCEDURE" has been previously conducted, always turn the ignition switch OFF and wait at least 10 seconds before conducting the next test.

>> GO TO 2.

2. CHECK DTC DETECTION

ⓂCONSULT

1. Turn the ignition switch OFF to ON.

**CAUTION:**

**Be sure to wait 10 seconds after turning ignition switch OFF or ON.**

2. Select "Self Diagnostic Result" mode of "CHASSIS CONTROL".

Is DTC "C1BBD-00" detected?

- YES >> Proceed to [DAS-249. "Diagnosis Procedure"](#).
- NO-1 >> To check malfunction symptom before repair: Refer to [GI-41. "Intermittent Incident"](#).
- NO-2 >> Confirmation after repair: Inspection End.

Diagnosis Procedure

INFOID:000000012271739

1. PERFORM SELF-DIAGNOSIS

ⓂCONSULT

1. Erase "Self Diagnostic Result" mode of "CHASSIS CONTROL".
2. Turn the ignition switch OFF and wait for 10 seconds or more.
3. Turn the ignition switch ON.
4. Select "Self Diagnostic Result" mode of "CHASSIS CONTROL".

Is DTC "C1BBD-00" detected?

- YES >> Perform configuration. Refer to [DAS-218. "Work Procedure"](#).
- NO >> Inspection End.

DAS

# C1BC0-00 FRONT RIGHT WHEEL SENSOR

< DTC/CIRCUIT DIAGNOSIS >

[CHASSIS CONTROL]

## C1BC0-00 FRONT RIGHT WHEEL SENSOR

### DTC Description

INFOID:000000012271740

### DTC DETECTION LOGIC

DTC No.	CONSULT screen terms (Trouble diagnosis content)	DTC detection condition	
C1BC0-00	FR WHEEL SENSOR (Front right wheel sensor)	Diagnosis condition	When ignition switch is ON.
		Signal (terminal)	–
		Threshold	When a malfunction is detected in front right wheel sensor system
		Diagnosis delay time	–

### POSSIBLE CAUSE

- Front right wheel sensor
- Front right sensor rotor
- ABS actuator and electric unit (control unit)
- Chassis control module

### FAIL-SAFE

The following functions are suspended:

- Active Trace Control function
- Active Ride Control function

### DTC CONFIRMATION PROCEDURE

#### 1. PRECONDITIONING

If “DTC CONFIRMATION PROCEDURE” has been previously conducted, always turn the ignition switch OFF and wait at least 10 seconds before conducting the next test.

>> GO TO 2.

#### 2. CHECK DTC DETECTION

##### ⓂCONSULT

1. Start the engine.
2. Drive the vehicle at approx. 19 mph (30 km/h) or more for approx. 1 minute.
3. Stop the vehicle.
4. Turn the ignition switch OFF to ON.

##### **CAUTION:**

**Be sure to wait 10 seconds after turning ignition switch OFF or ON.**

5. Select “Self Diagnostic Result” mode of “CHASSIS CONTROL”.

Is DTC “C1BC0-00” detected?

- YES >> Proceed to [DAS-250. "Diagnosis Procedure"](#).  
NO-1 >> To check malfunction symptom before repair: Refer to [GI-41. "Intermittent Incident"](#).  
NO-2 >> Confirmation after repair: Inspection End.

### Diagnosis Procedure

INFOID:000000012271741

#### 1. CHECK FRONT RH WHEEL SENSOR SYSTEM

##### ⓂCONSULT

Select “Self Diagnostic Result” mode of “ABS”.

Is DTC detected?

- YES >> Check the DTC. Refer to [BRC-227. "DTC Index"](#).  
NO >> GO TO 2.

#### 2. PERFORM SELF-DIAGNOSIS

# C1BC0-00 FRONT RIGHT WHEEL SENSOR

< DTC/CIRCUIT DIAGNOSIS >

[CHASSIS CONTROL]

## CONSULT

1. Erase "Self Diagnostic Result" mode of "CHASSIS CONTROL".
2. Turn the ignition switch OFF and wait for 10 seconds or more.
3. Turn the ignition switch ON.
4. Select "All DTC Reading" mode.

Is DTC "C1BC0-00", "U1000-00" or other DTC detected?

YES ("C1BC0-00")>> Replace the chassis control module. Refer to [DAS-290, "Removal and Installation"](#).

YES ("U1000-00")>> Refer to [DAS-264, "Diagnosis Procedure"](#).

YES (other DTC)>> Check the DTC.

NO >> Inspection End.

A  
B  
C  
D  
E  
F  
G  
H  
I  
J  
K  
L  
M  
N  
P

DAS

# C1BC1-00 FRONT LEFT WHEEL SENSOR

< DTC/CIRCUIT DIAGNOSIS >

[CHASSIS CONTROL]

## C1BC1-00 FRONT LEFT WHEEL SENSOR

### DTC Description

INFOID:000000012271742

### DTC DETECTION LOGIC

DTC No.	CONSULT screen terms (Trouble diagnosis content)	DTC detection condition	
C1BC1-00	FL WHEEL SENSOR (Front left wheel sensor)	Diagnosis condition	When ignition switch is ON.
		Signal (terminal)	—
		Threshold	When a malfunction is detected in front left wheel sensor system
		Diagnosis delay time	—

### POSSIBLE CAUSE

- Front left wheel sensor
- Front left sensor rotor
- ABS actuator and electric unit (control unit)
- Chassis control module

### FAIL-SAFE

The following functions are suspended:

- Active Trace Control function
- Active Ride Control function

### DTC CONFIRMATION PROCEDURE

#### 1. PRECONDITIONING

If “DTC CONFIRMATION PROCEDURE” has been previously conducted, always turn the ignition switch OFF and wait at least 10 seconds before conducting the next test.

>> GO TO 2.

#### 2. CHECK DTC DETECTION

##### CONSULT

1. Start the engine.
2. Drive the vehicle at approx. 19 mph (30 km/h) or more for approx. 1 minute.
3. Stop the vehicle.
4. Turn the ignition switch OFF to ON.

##### CAUTION:

**Be sure to wait 10 seconds after turning ignition switch OFF or ON.**

5. Select “Self Diagnostic Result” mode of “CHASSIS CONTROL”.

Is DTC “C1BC1-00” detected?

- YES >> Proceed to [DAS-252. "Diagnosis Procedure"](#).  
NO-1 >> To check malfunction symptom before repair: Refer to [GI-41. "Intermittent Incident"](#).  
NO-2 >> Confirmation after repair: Inspection End.

### Diagnosis Procedure

INFOID:000000012271743

#### 1. CHECK FRONT LH WHEEL SENSOR SYSTEM

##### CONSULT

Select “Self Diagnostic Result” mode of “ABS”.

Is DTC detected?

- YES >> Check the DTC. Refer to [BRC-227. "DTC Index"](#).  
NO >> GO TO 2.

#### 2. PERFORM SELF-DIAGNOSIS

##### CONSULT



## C1BC1-00 FRONT LEFT WHEEL SENSOR

< DTC/CIRCUIT DIAGNOSIS >

[CHASSIS CONTROL]

1. Erase "Self Diagnostic Result" mode of "CHASSIS CONTROL".
2. Turn the ignition switch OFF and wait for 10 seconds or more.
3. Turn the ignition switch ON.
4. Select "All DTC Reading" mode.

Is DTC "C1BC1-00", "U1000-00" or other DTC detected?

YES ("C1BC1-00")>> Replace the chassis control module. Refer to [DAS-290, "Removal and Installation"](#).

YES ("U1000-00")>> Refer to [DAS-264, "Diagnosis Procedure"](#).

YES (other DTC)>> Check the DTC.

NO >> Inspection End.

A

B

C

D

E

F

G

H

I

J

K

L

M

N

DAS

P

# C1BC2-00 REAR RIGHT WHEEL SENSOR

< DTC/CIRCUIT DIAGNOSIS >

[CHASSIS CONTROL]

## C1BC2-00 REAR RIGHT WHEEL SENSOR

### DTC Description

INFOID:000000012271744

### DTC DETECTION LOGIC

DTC No.	CONSULT screen terms (Trouble diagnosis content)	DTC detection condition	
C1BC2-00	RR WHEEL SENSOR (Rear right wheel sensor)	Diagnosis condition	When ignition switch is ON.
		Signal (terminal)	–
		Threshold	When a malfunction is detected in rear right wheel sensor system
		Diagnosis delay time	–

### POSSIBLE CAUSE

- Rear right wheel sensor
- Rear right sensor rotor
- ABS actuator and electric unit (control unit)
- Chassis control module

### FAIL-SAFE

The following functions are suspended:

- Active Trace Control function
- Active Ride Control function

### DTC CONFIRMATION PROCEDURE

#### 1. PRECONDITIONING

If “DTC CONFIRMATION PROCEDURE” has been previously conducted, always turn the ignition switch OFF and wait at least 10 seconds before conducting the next test.

>> GO TO 2.

#### 2. CHECK DTC DETECTION

##### CONSULT

1. Start the engine.
2. Drive the vehicle at approx. 19 mph (30 km/h) or more for approx. 1 minute.
3. Stop the vehicle.
4. Turn the ignition switch OFF to ON.

##### CAUTION:

**Be sure to wait 10 seconds after turning ignition switch OFF or ON.**

5. Select “Self Diagnostic Result” mode of “CHASSIS CONTROL”.

Is DTC “C1BC2-00” detected?

- YES >> Proceed to [DAS-254. "Diagnosis Procedure"](#).  
NO-1 >> To check malfunction symptom before repair: Refer to [GI-41. "Intermittent Incident"](#).  
NO-2 >> Confirmation after repair: Inspection End.

### Diagnosis Procedure

INFOID:000000012271745

#### 1. CHECK REAR RH WHEEL SENSOR SYSTEM

##### CONSULT

Select “Self Diagnostic Result” mode of “ABS”.

Is DTC detected?

- YES >> Check the DTC. Refer to [BRC-227. "DTC Index"](#).  
NO >> GO TO 2.

#### 2. PERFORM SELF-DIAGNOSIS

##### CONSULT

## C1BC2-00 REAR RIGHT WHEEL SENSOR

< DTC/CIRCUIT DIAGNOSIS >

[CHASSIS CONTROL]

1. Erase "Self Diagnostic Result" mode of "CHASSIS CONTROL".
2. Turn the ignition switch OFF and wait for 10 seconds or more.
3. Turn the ignition switch ON.
4. Select "All DTC Reading" mode.

Is DTC "C1BC2-00", "U1000-00" or other DTC detected?

YES ("C1BC2-00")>> Replace the chassis control module. Refer to [DAS-290, "Removal and Installation"](#).

YES ("U1000-00")>> Refer to [DAS-264, "Diagnosis Procedure"](#).

YES (other DTC)>> Check the DTC.

NO >> Inspection End.

A

B

C

D

E

F

G

H

I

J

K

L

M

N

DAS

P

# C1BC3-00 REAR LEFT WHEEL SENSOR

< DTC/CIRCUIT DIAGNOSIS >

[CHASSIS CONTROL]

## C1BC3-00 REAR LEFT WHEEL SENSOR

### DTC Description

INFOID:000000012271746

### DTC DETECTION LOGIC

DTC No.	CONSULT screen terms (Trouble diagnosis content)	DTC detection condition	
C1BC3-00	RL WHEEL SENSOR (Rear left wheel sensor)	Diagnosis condition	When ignition switch is ON.
		Signal (terminal)	–
		Threshold	When a malfunction is detected in rear left wheel sensor system
		Diagnosis delay time	–

### POSSIBLE CAUSE

- Rear left wheel sensor
- Rear left sensor rotor
- ABS actuator and electric unit (control unit)
- Chassis control module

### FAIL-SAFE

The following functions are suspended:

- Active Trace Control function
- Active Ride Control function

### DTC CONFIRMATION PROCEDURE

#### 1. PRECONDITIONING

If “DTC CONFIRMATION PROCEDURE” has been previously conducted, always turn the ignition switch OFF and wait at least 10 seconds before conducting the next test.

>> GO TO 2.

#### 2. CHECK DTC DETECTION

##### ⓂCONSULT

1. Start the engine.
2. Drive the vehicle at approx. 19 mph (30 km/h) or more for approx. 1 minute.
3. Stop the vehicle.
4. Turn the ignition switch OFF to ON.

##### **CAUTION:**

**Be sure to wait 10 seconds after turning ignition switch OFF or ON.**

5. Select “Self Diagnostic Result” mode of “CHASSIS CONTROL”.

##### Is DTC “C1BC3-00” detected?

- YES >> Proceed to [DAS-256. "Diagnosis Procedure"](#).  
NO-1 >> To check malfunction symptom before repair: Refer to [GI-41. "Intermittent Incident"](#).  
NO-2 >> Confirmation after repair: Inspection End.

### Diagnosis Procedure

INFOID:000000012271747

#### 1. CHECK REAR LH WHEEL SENSOR SYSTEM

##### ⓂCONSULT

Select “Self Diagnostic Result” mode of “ABS”.

##### Is DTC detected?

- YES >> Check the DTC. Refer to [BRC-227. "DTC Index"](#).  
NO >> GO TO 2.

#### 2. PERFORM SELF-DIAGNOSIS

##### ⓂCONSULT

## C1BC3-00 REAR LEFT WHEEL SENSOR

< DTC/CIRCUIT DIAGNOSIS >

[CHASSIS CONTROL]

1. Erase "Self Diagnostic Result" mode of "CHASSIS CONTROL".
2. Turn the ignition switch OFF and wait for 10 seconds or more.
3. Turn the ignition switch ON.
4. Select "All DTC Reading" mode.

Is DTC "C1BC3-00", "U1000-00" or other DTC detected?

YES ("C1BC3-00")>> Replace the chassis control module. Refer to [DAS-290, "Removal and Installation"](#).

YES ("U1000-00")>> Refer to [DAS-264, "Diagnosis Procedure"](#).

YES (other DTC)>> Check the DTC.

NO >> Inspection End.

A

B

C

D

E

F

G

H

I

J

K

L

M

N

DAS

P

## C1BC4-00 DECEL G SENSOR

### DTC Description

INFOID:000000012271748

### DTC DETECTION LOGIC

DTC No.	CONSULT screen terms (Trouble diagnosis content)	DTC detection condition	
C1BC4-00	DECEL G SENSOR (Decel G sensor)	Diagnosis condition	When ignition switch is ON.
		Signal (terminal)	-
		Threshold	When a malfunction is detected in decel G sensor system
		Diagnosis delay time	-

### POSSIBLE CAUSE

- Yaw rate/side/decel G sensor [integrated in ABS actuator and electric unit (control unit)]
- ABS actuator and electric unit (control unit)
- Chassis control module

### FAIL-SAFE

The following function is suspended:

- Active Ride Control (brake) function

### DTC CONFIRMATION PROCEDURE

#### 1. PRECONDITIONING

If "DTC CONFIRMATION PROCEDURE" has been previously conducted, always turn the ignition switch OFF and wait at least 10 seconds before conducting the next test.

>> GO TO 2.

#### 2. CHECK DTC DETECTION

##### CONSULT

1. Turn the ignition switch OFF to ON.

**CAUTION:**

**Be sure to wait 10 seconds after turning ignition switch OFF or ON.**

2. Select "Self Diagnostic Result" mode of "CHASSIS CONTROL".

##### Is DTC "C1BC4-00" detected?

YES >> Proceed to [DAS-258, "Diagnosis Procedure"](#).

NO-1 >> To check malfunction symptom before repair: Refer to [GI-41, "Intermittent Incident"](#).

NO-2 >> Confirmation after repair: Inspection End.

### Diagnosis Procedure

INFOID:000000012271749

#### 1. CHECK DECEL G SENSOR SYSTEM

##### CONSULT

Select "Self Diagnostic Result" mode of "ABS".

##### Is DTC detected?

YES >> Check the DTC. Refer to [BRC-227, "DTC Index"](#).

NO >> GO TO 2.

#### 2. PERFORM SELF-DIAGNOSIS

##### CONSULT

1. Erase "Self Diagnostic Result" mode of "CHASSIS CONTROL".
2. Turn the ignition switch OFF and wait for 10 seconds or more.
3. Turn the ignition switch ON.
4. Select "All DTC Reading" mode.

# C1BC4-00 DECEL G SENSOR

< DTC/CIRCUIT DIAGNOSIS >

[CHASSIS CONTROL]

Is DTC "C1BC4-00", "U1000-00" or other DTC detected?

YES ("C1BC4-00")>> Replace the chassis control module. Refer to [DAS-290, "Removal and Installation"](#).

YES ("U1000-00")>> Refer to [DAS-264, "Diagnosis Procedure"](#).

YES (other DTC)>> Check the DTC.

NO >> Inspection End.

A

B

C

D

E

F

G

H

I

J

K

L

M

N

DAS

P

## C1BC5-00 SIDE G SENSOR

### DTC Description

INFOID:000000012271750

### DTC DETECTION LOGIC

DTC No.	CONSULT screen terms (Trouble diagnosis content)	DTC detection condition	
C1BC5-00	SIDE G SENSOR (Side G sensor)	Diagnosis condition	When ignition switch is ON.
		Signal (terminal)	-
		Threshold	When a malfunction is detected in side G sensor system
		Diagnosis delay time	-

### POSSIBLE CAUSE

- Yaw rate/side/decel G sensor [integrated in ABS actuator and electric unit (control unit)]
- ABS actuator and electric unit (control unit)
- Chassis control module

### FAIL-SAFE

The following function is suspended:

- Active Trace Control function

### DTC CONFIRMATION PROCEDURE

#### 1. PRECONDITIONING

If "DTC CONFIRMATION PROCEDURE" has been previously conducted, always turn the ignition switch OFF and wait at least 10 seconds before conducting the next test.

>> GO TO 2.

#### 2. CHECK DTC DETECTION

##### CONSULT

1. Turn the ignition switch OFF to ON.

**CAUTION:**

**Be sure to wait 10 seconds after turning ignition switch OFF or ON.**

2. Select "Self Diagnostic Result" mode of "CHASSIS CONTROL".

##### Is DTC "C1BC5-00" detected?

YES >> Proceed to [DAS-260, "Diagnosis Procedure"](#).

NO-1 >> To check malfunction symptom before repair: Refer to [GI-41, "Intermittent Incident"](#).

NO-2 >> Confirmation after repair: Inspection End.

### Diagnosis Procedure

INFOID:000000012271751

#### 1. CHECK SIDE G SENSOR SYSTEM

##### CONSULT

Select "Self Diagnostic Result" mode of "ABS".

##### Is DTC detected?

YES >> Check the DTC. Refer to [BRC-227, "DTC Index"](#).

NO >> GO TO 2.

#### 2. PERFORM SELF-DIAGNOSIS

##### CONSULT

1. Erase "Self Diagnostic Result" mode of "CHASSIS CONTROL".
2. Turn the ignition switch OFF and wait for 10 seconds or more.
3. Turn the ignition switch ON.
4. Select "All DTC Reading" mode.



# C1BC5-00 SIDE G SENSOR

< DTC/CIRCUIT DIAGNOSIS >

[CHASSIS CONTROL]

Is DTC "C1BC5-00", "U1000-00" or other DTC detected?

YES ("C1BC5-00")>> Replace the chassis control module. Refer to [DAS-290, "Removal and Installation"](#).

YES ("U1000-00")>> Refer to [DAS-264, "Diagnosis Procedure"](#).

YES (other DTC)>> Check the DTC.

NO >> Inspection End.

A  
B  
C  
D  
E  
F  
G  
H  
I  
J  
K  
L  
M  
N  
P

DAS

# C1BC6-00 PRESSURE SENSOR

< DTC/CIRCUIT DIAGNOSIS >

[CHASSIS CONTROL]

## C1BC6-00 PRESSURE SENSOR

### DTC Description

INFOID:000000012271752

### DTC DETECTION LOGIC

DTC No.	CONSULT screen terms (Trouble diagnosis content)	DTC detection condition	
C1BC6-00	PRESSURE SENSOR (Pressure sensor)	Diagnosis condition	When ignition switch is ON.
		Signal (terminal)	—
		Threshold	When a malfunction is detected in brake fluid pressure system
		Diagnosis delay time	—

### POSSIBLE CAUSE

- ABS actuator and electric unit (control unit)
- Chassis control module

### FAIL-SAFE

The following functions are suspended:

- Active Trace Control function
- Active Ride Control (brake) function

### DTC CONFIRMATION PROCEDURE

#### 1.PRECONDITIONING

If “DTC CONFIRMATION PROCEDURE” has been previously conducted, always turn the ignition switch OFF and wait at least 10 seconds before conducting the next test.

>> GO TO 2.

#### 2.CHECK DTC DETECTION

##### CONSULT

1. Turn the ignition switch OFF to ON.

##### CAUTION:

**Be sure to wait 10 seconds after turning ignition switch OFF or ON.**

2. Select “Self Diagnostic Result” mode of “CHASSIS CONTROL”.

##### Is DTC “C1BC6-00” detected?

- YES >> Proceed to [DAS-262, "Diagnosis Procedure"](#).  
NO-1 >> To check malfunction symptom before repair: Refer to [GI-41, "Intermittent Incident"](#).  
NO-2 >> Confirmation after repair: Inspection End.

### Diagnosis Procedure

INFOID:000000012271753

#### 1.CHECK BRAKE FLUID PRESSURE SYSTEM

##### CONSULT

Select “Self Diagnostic Result” mode of “ABS”.

##### Is DTC detected?

- YES >> Check the DTC. Refer to [BRC-227, "DTC Index"](#).  
NO >> GO TO 2.

#### 2.PERFORM SELF-DIAGNOSIS

##### CONSULT

1. Erase “Self Diagnostic Result” mode of “CHASSIS CONTROL”.
2. Turn the ignition switch OFF and wait for 10 seconds or more.
3. Turn the ignition switch ON.
4. Select “All DTC Reading” mode.

## C1BC6-00 PRESSURE SENSOR

< DTC/CIRCUIT DIAGNOSIS >

[CHASSIS CONTROL]

Is DTC "C1BC6-00", "U1000-00" or other DTC detected?

YES ("C1BC6-00")>> Replace the chassis control module. Refer to [DAS-290, "Removal and Installation"](#).

YES ("U1000-00")>> Refer to [DAS-264, "Diagnosis Procedure"](#).

YES (other DTC)>> Check the DTC.

NO >> Inspection End.

A  
B  
C  
D  
E  
F  
G  
H  
I  
J  
K  
L  
M  
N  
P

DAS

# U1000-00 CAN COMM CIRCUIT

< DTC/CIRCUIT DIAGNOSIS >

[CHASSIS CONTROL]

## U1000-00 CAN COMM CIRCUIT

### DTC Logic

INFOID:000000012271754

### DTC DETECTION LOGIC

DTC No.	CONSULT screen terms (Trouble diagnosis content)	DTC detection condition	
U1000-00	CAN COMM CIRCUIT (CAN communication circuit)	Diagnosis condition	When ignition switch is ON.
		Signal (terminal)	–
		Threshold	Chassis control module is not transmitting or receiving CAN communication signal
		Diagnosis delay time	2 seconds or more

### POSSIBLE CAUSE

CAN communication system

### FAIL-SAFE

The following functions are suspended:

- Active Trace Control function
- Active Ride Control function
- Active Engine Brake function

### DTC CONFIRMATION PROCEDURE

#### 1. PRECONDITIONING

If "DTC CONFIRMATION PROCEDURE" has been previously conducted, always turn the ignition switch OFF and wait at least 10 seconds before conducting the next test.

>> GO TO 2.

#### 2. CHECK DTC DETECTION

##### CONSULT

1. Turn the ignition switch OFF to ON.

##### CAUTION:

**Be sure to wait 10 seconds after turning ignition switch OFF or ON.**

2. Select "Self Diagnostic Result" mode of "CHASSIS CONTROL".

##### Is DTC "U1000-00" detected?

YES >> Proceed to [DAS-264, "Diagnosis Procedure"](#).

NO-1 >> To check malfunction symptom before repair: Refer to [GI-41, "Intermittent Incident"](#).

NO-2 >> Confirmation after repair: Inspection End.

### Diagnosis Procedure

INFOID:000000012271755

Proceed to [LAN-17, "Trouble Diagnosis Flow Chart"](#).

# U1A34-00 BRAKE CONTROL COMMUNICATION

< DTC/CIRCUIT DIAGNOSIS >

[CHASSIS CONTROL]

## U1A34-00 BRAKE CONTROL COMMUNICATION

### DTC Description

INFOID:0000000012271756

### DTC DETECTION LOGIC

DTC No.	CONSULT screen terms (Trouble diagnosis content)	DTC detection condition	
U1A34-00	BRAKE CONTROL COMM (Brake control communication)	Diagnosis condition	When ignition switch is ON.
		Signal (terminal)	–
		Threshold	When chassis control module is not receiving CAN communication signal [between chassis control module and ABS actuator and electric unit (control unit)]
		Diagnosis delay time	2 seconds or more

### POSSIBLE CAUSE

- ABS actuator and electric unit (control unit)
- Chassis control module
- CAN communication line

### FAIL-SAFE

The following functions are suspended:

- Active Trace Control function
- Active Ride Control function
- Active Engine Brake function

### DTC CONFIRMATION PROCEDURE

#### 1. PRECONDITIONING

If "DTC CONFIRMATION PROCEDURE" has been previously conducted, always turn the ignition switch OFF and wait at least 10 seconds before conducting the next test.

>> GO TO 2.

#### 2. CHECK DTC DETECTION

##### Ⓜ CONSULT

1. Turn the ignition switch OFF to ON.

##### **CAUTION:**

**Be sure to wait 10 seconds after turning ignition switch OFF or ON.**

2. Select "Self Diagnostic Result" mode of "CHASSIS CONTROL".

Is DTC "U1A34-00" detected?

YES >> Proceed to [DAS-265. "Diagnosis Procedure"](#).

NO-1 >> To check malfunction symptom before repair: Refer to [GI-41. "Intermittent Incident"](#).

NO-2 >> Confirmation after repair: Inspection End.

### Diagnosis Procedure

INFOID:0000000012271757

Regarding Wiring Diagram information, refer to [DAS-212. "Wiring Diagram"](#).

#### 1. CHECK CAN DIAGNOSIS SUPPORT MONITOR

##### Ⓜ CONSULT

1. Select "CAN Diagnosis Support Monitor" mode of "CHASSIS CONTROL".
2. Check for malfunction between each control unit connected to chassis control module.

Check the result of "PRESENT"?

A  
B  
C  
D  
E  
F  
G  
H  
I  
J  
K  
L  
M  
N  
P

# U1A34-00 BRAKE CONTROL COMMUNICATION

< DTC/CIRCUIT DIAGNOSIS >

[CHASSIS CONTROL]

Refer to >> [LAN-30, "CAN COMMUNICATION SYSTEM : CAN Communication Control Circuit"](#).

"TRANSMIT DIAG" is other than "OK">> GO TO 2.

"ABS" other than "OK">> GO TO 3.

## 2.CHECK TRANSMITTING SIDE UNIT

1. Turn the ignition switch OFF.
2. Disconnect chassis control module harness connector.
3. Check the chassis control module harness connector terminals 3 and 4 for damage or loose connection.

Is the inspection result normal?

YES >> GO TO 5.

NO >> Recheck terminals for damage or loose connection. Refer to [LAN-7, "Precautions for Harness Repair"](#). GO TO 5.

## 3.CHECK ABS ACTUATOR AND ELECTRIC UNIT (CONTROL UNIT)

1. Turn the ignition switch OFF.
2. Disconnect ABS actuator and electric unit (control unit) harness connector.
3. Check ABS actuator and electric unit (control unit) harness connector terminals (CAN communication line) for damage or loose connection.

Is the inspection result normal?

YES >> GO TO 4.

NO >> Recheck terminals for damage or loose connection. Refer to [LAN-7, "Precautions for Harness Repair"](#). GO TO 4.

## 4.PERFORM SELF-DIAGNOSIS [ABS ACTUATOR AND ELECTRIC UNIT (CONTROL UNIT)]

### ⓅCONSULT

1. Connect ABS actuator and electric unit (control unit) harness connector.
2. Erase "Self Diagnostic Result" mode of "ABS".
3. Turn the ignition switch OFF and wait for 10 seconds or more.
4. Turn the ignition switch ON.
5. Select "Self Diagnostic Result" mode of "ABS".

Is DTC detected?

YES >> Check the DTC. Refer to [BRC-227, "DTC Index"](#).

NO >> GO TO 5.

## 5.PERFORM SELF-DIAGNOSIS

### ⓅCONSULT

1. Connect chassis control module harness connector.
2. Erase "Self Diagnostic Result" mode of "CHASSIS CONTROL".
3. Turn the ignition switch OFF and wait for 10 seconds or more.
4. Turn the ignition switch ON.
5. Select "All DTC Reading" mode.

Is DTC "U1000-00", "U1A34-00" or other DTC detected?

YES ("U1000-00")>> Refer to [DAS-264, "Diagnosis Procedure"](#).

YES ("U1A34-00")>> Replace the chassis control module. Refer to [DAS-290, "Removal and Installation"](#).

YES (other DTC)>> Check the DTC.

NO >> Inspection End.

# U1A35-00 BRAKE CONTROL COMMUNICATION

< DTC/CIRCUIT DIAGNOSIS >

[CHASSIS CONTROL]

## U1A35-00 BRAKE CONTROL COMMUNICATION

### DTC Description

INFOID:000000012271758

### DTC DETECTION LOGIC

DTC No.	CONSULT screen terms (Trouble diagnosis content)	DTC detection condition	
U1A35-00	BRAKE CONTROL COMM (Brake control communication)	Diagnosis condition	When ignition switch is ON.
		Signal (terminal)	–
		Threshold	A calculated signal value differs between a signal transmitted from the ABS actuator and electric unit (control unit) and a signal received from chassis control module via CAN communication
		Diagnosis delay time	–

### POSSIBLE CAUSE

- ABS actuator and electric unit (control unit)
- Chassis control module
- CAN communication line

### FAIL-SAFE

The following functions are suspended:

- Active Trace Control function
- Active Ride Control function
- Active Engine Brake function

### DTC CONFIRMATION PROCEDURE

#### 1. PRECONDITIONING

If "DTC CONFIRMATION PROCEDURE" has been previously conducted, always turn the ignition switch OFF and wait at least 10 seconds before conducting the next test.

>> GO TO 2.

#### 2. CHECK DTC DETECTION

##### ⓂCONSULT

1. Turn the ignition switch OFF to ON.

##### **CAUTION:**

**Be sure to wait 10 seconds after turning ignition switch OFF or ON.**

2. Select "Self Diagnostic Result" mode of "CHASSIS CONTROL".

Is DTC "U1A35-00" detected?

YES >> Proceed to [DAS-267. "Diagnosis Procedure"](#).

NO-1 >> To check malfunction symptom before repair: Refer to [GI-41. "Intermittent Incident"](#).

NO-2 >> Confirmation after repair: Inspection End.

### Diagnosis Procedure

INFOID:000000012271759

DAS

Regarding Wiring Diagram information, refer to [DAS-212. "Wiring Diagram"](#).

#### 1. CHECK CAN DIAGNOSIS SUPPORT MONITOR

##### ⓂCONSULT

1. Select "CAN Diagnosis Support Monitor" mode of "CHASSIS CONTROL".
2. Check for malfunction between each control unit connected to chassis control module.

Check the result of "PRESENT"?

# U1A35-00 BRAKE CONTROL COMMUNICATION

< DTC/CIRCUIT DIAGNOSIS >

[CHASSIS CONTROL]

>> Refer to [LAN-9, "CAN Communication Control Circuit"](#).

"TRANSMIT DIAG" is other than "OK">> GO TO 2.

"ABS" other than "OK">> GO TO 3.

## 2. CHECK TRANSMITTING SIDE UNIT

1. Turn the ignition switch OFF.
2. Disconnect chassis control module harness connector.
3. Check the chassis control module harness connector terminals 3 and 4 for damage or loose connection.

Is the inspection result normal?

YES >> GO TO 5.

NO >> Recheck terminals for damage or loose connection. Refer to [LAN-7, "Precautions for Harness Repair"](#). GO TO 5.

## 3. CHECK ABS ACTUATOR AND ELECTRIC UNIT (CONTROL UNIT)

1. Turn the ignition switch OFF.
2. Disconnect ABS actuator and electric unit (control unit) harness connector.
3. Check ABS actuator and electric unit (control unit) harness connector terminals (CAN communication line) for damage or loose connection.

Is the inspection result normal?

YES >> GO TO 4.

NO >> Recheck terminals for damage or loose connection. Refer to [LAN-7, "Precautions for Harness Repair"](#). GO TO 4.

## 4. PERFORM SELF-DIAGNOSIS [ABS ACTUATOR AND ELECTRIC UNIT (CONTROL UNIT)]

### ⓅCONSULT

1. Connect ABS actuator and electric unit (control unit) harness connector.
2. Erase "Self Diagnostic Result" mode of "ABS".
3. Turn the ignition switch OFF and wait for 10 seconds or more.
4. Turn the ignition switch ON.
5. Select "Self Diagnostic Result" mode of "ABS".

Is DTC detected?

YES >> Check the DTC. Refer to [BRC-227, "DTC Index"](#).

NO >> GO TO 5.

## 5. PERFORM SELF-DIAGNOSIS

### ⓅCONSULT

1. Connect chassis control module harness connector.
2. Erase "Self Diagnostic Result" mode of "CHASSIS CONTROL".
3. Turn the ignition switch OFF and wait for 10 seconds or more.
4. Turn the ignition switch ON.
5. Select "All DTC Reading" mode.

Is DTC "U1000-00", "U1A35-00" or other DTC detected?

YES ("U1000-00")>> Refer to [DAS-264, "Diagnosis Procedure"](#).

YES ("U1A35-00")>> Replace the chassis control module. Refer to [DAS-290, "Removal and Installation"](#).

YES (other DTC)>> Check the DTC.

NO >> Inspection End.



# U1A36-00 BCM/IPDM COMMUNICATION

< DTC/CIRCUIT DIAGNOSIS >

[CHASSIS CONTROL]

## U1A36-00 BCM/IPDM COMMUNICATION

### DTC Description

INFOID:000000012271760

### DTC DETECTION LOGIC

DTC No.	CONSULT screen terms (Trouble diagnosis content)	DTC detection condition	
U1A36-00	BCM/IPDM COMM (BCM/IPDM communication)	Diagnosis condition	When ignition switch is ON.
		Signal (terminal)	–
		Threshold	When chassis control module is not receiving CAN communication signal (between chassis control module and BCM)
		Diagnosis delay time	2 seconds or more

### POSSIBLE CAUSE

- BCM
- Chassis control module
- CAN communication line

### FAIL-SAFE

The following functions are suspended:

- Active Trace Control function
- Active Ride Control function
- Active Engine Brake function

### DTC CONFIRMATION PROCEDURE

#### 1. PRECONDITIONING

If "DTC CONFIRMATION PROCEDURE" has been previously conducted, always turn the ignition switch OFF and wait at least 10 seconds before conducting the next test.

>> GO TO 2.

#### 2. CHECK DTC DETECTION

##### CONSULT

1. Turn the ignition switch OFF to ON.

##### CAUTION:

**Be sure to wait 10 seconds after turning ignition switch OFF or ON.**

2. Select "Self Diagnostic Result" mode of "CHASSIS CONTROL".

Is DTC "U1A36-00" detected?

YES >> Proceed to [DAS-269. "Diagnosis Procedure"](#).

NO-1 >> To check malfunction symptom before repair: Refer to [GI-41. "Intermittent Incident"](#).

NO-2 >> Confirmation after repair: Inspection End.

### Diagnosis Procedure

INFOID:000000012271761

Regarding Wiring Diagram information, refer to [DAS-212. "Wiring Diagram"](#).

#### 1. CHECK CAN DIAGNOSIS SUPPORT MONITOR

##### CONSULT

1. Select "CAN Diagnosis Support Monitor" mode of "CHASSIS CONTROL".
2. Check for malfunction between each control unit connected to chassis control module.

Check the result of "PRESENT"?

>> Refer to [LAN-9. "CAN Communication Control Circuit"](#).

A  
B  
C  
D  
E  
F  
G  
H  
I  
J  
K  
L  
M  
N  
P

# U1A36-00 BCM/IPDM COMMUNICATION

< DTC/CIRCUIT DIAGNOSIS >

[CHASSIS CONTROL]

"TRANSMIT DIAG" is other than "OK">> GO TO 2.

"BCM" other than "OK">> GO TO 3.

## 2.CHECK TRANSMITTING SIDE UNIT

1. Turn the ignition switch OFF.
2. Disconnect chassis control module harness connector.
3. Check the chassis control module harness connector terminals 3 and 4 for damage or loose connection.

Is the inspection result normal?

YES >> GO TO 5.

NO >> Recheck terminals for damage or loose connection. Refer to [LAN-7, "Precautions for Harness Repair"](#). GO TO 5.

## 3.CHECK BCM

1. Turn the ignition switch OFF.
2. Disconnect BCM harness connector.
3. Check BCM harness connector terminals (CAN communication line) or damage or loose connection.

Is the inspection result normal?

YES >> GO TO 4.

NO >> Recheck terminals for damage or loose connection. Refer to [LAN-7, "Precautions for Harness Repair"](#). GO TO 4.

## 4.PERFORM SELF-DIAGNOSIS (BCM)

ⓅCONSULT

1. Connect BCM harness connector.
2. Erase "Self Diagnostic Result" mode of "BCM".
3. Turn the ignition switch OFF and wait for 10 seconds or more.
4. Turn the ignition switch ON.
5. Select "Self Diagnostic Result" mode of "BCM".

Is DTC detected?

YES >> Check the DTC. Refer to [BCS-53, "DTC Index"](#).

NO >> GO TO 5.

## 5.PERFORM SELF-DIAGNOSIS

ⓅCONSULT

1. Connect chassis control module harness connector.
2. Erase "Self Diagnostic Result" mode of "CHASSIS CONTROL".
3. Turn the ignition switch OFF and wait for 10 seconds or more.
4. Turn the ignition switch ON.
5. Select "All DTC Reading" mode.

Is DTC "U1000-00", "U1A36-00" or other DTC detected?

YES ("U1000-00")>> Refer to [DAS-264, "Diagnosis Procedure"](#).

YES ("U1A36-00")>> Replace the chassis control module. Refer to [DAS-290, "Removal and Installation"](#).

YES (other DTC)>> Check the DTC.

NO >> Inspection End.

# U1A39-00 COMBINATION METER COMMUNICATION

< DTC/CIRCUIT DIAGNOSIS >

[CHASSIS CONTROL]

## U1A39-00 COMBINATION METER COMMUNICATION

### DTC Description

INFOID:000000012271762

### DTC DETECTION LOGIC

DTC No.	CONSULT screen terms (Trouble diagnosis content)	DTC detection condition	
U1A39-00	COMBINATION METER COMM (Combination meter communication)	Diagnosis condition	When ignition switch is ON.
		Signal (terminal)	—
		Threshold	When chassis control module is not receiving CAN communication signal (between chassis control module and combination meter)
		Diagnosis delay time	2 seconds or more

### POSSIBLE CAUSE

- Combination meter
- Chassis control module
- CAN communication line

### DTC CONFIRMATION PROCEDURE

#### 1. PRECONDITIONING

If "DTC CONFIRMATION PROCEDURE" has been previously conducted, always turn the ignition switch OFF and wait at least 10 seconds before conducting the next test.

>> GO TO 2.

#### 2. CHECK DTC DETECTION

##### CONSULT

1. Turn the ignition switch OFF to ON.

##### CAUTION:

**Be sure to wait 10 seconds after turning ignition switch OFF or ON.**

2. Select "Self Diagnostic Result" mode of "CHASSIS CONTROL".

Is DTC "U1A39-00" detected?

YES >> Proceed to [DAS-271, "Diagnosis Procedure"](#).

NO-1 >> To check malfunction symptom before repair: Refer to [GI-41, "Intermittent Incident"](#).

NO-2 >> Confirmation after repair: Inspection End.

### Diagnosis Procedure

INFOID:000000012271763

Regarding Wiring Diagram information, refer to [DAS-212, "Wiring Diagram"](#).

#### 1. CHECK CAN DIAGNOSIS SUPPORT MONITOR

##### CONSULT

1. Select "CAN Diagnosis Support Monitor" mode of "CHASSIS CONTROL".
2. Check for malfunction between each control unit connected to chassis control module.

Check the result of "PRESENT"?

>> Refer to [LAN-9, "CAN Communication Control Circuit"](#).

"TRANSMIT DIAG" is other than "OK">> GO TO 2.

"METER/M&A" other than "OK">> GO TO 3.

#### 2. CHECK TRANSMITTING SIDE UNIT

1. Turn the ignition switch OFF.

# U1A39-00 COMBINATION METER COMMUNICATION

[CHASSIS CONTROL]

< DTC/CIRCUIT DIAGNOSIS >

2. Disconnect chassis control module harness connector.
3. Check the chassis control module harness connector terminals 3 and 4 for damage or loose connection.

Is the inspection result normal?

YES >> GO TO 5.

NO >> Recheck terminals for damage or loose connection. Refer to [LAN-7, "Precautions for Harness Repair"](#). GO TO 5.

## 3. CHECK COMBINATION METER

1. Turn the ignition switch OFF.
2. Disconnect combination meter harness connector.
3. Check combination meter harness connector terminals (CAN communication line) or damage or loose connection.

Is the inspection result normal?

YES >> GO TO 4.

NO >> Recheck terminals for damage or loose connection. Refer to [LAN-7, "Precautions for Harness Repair"](#). GO TO 4.

## 4. PERFORM SELF-DIAGNOSIS (COMBINATION METER)

ⓂCONSULT

1. Connect combination meter harness connector.
2. Erase "Self Diagnostic Result" mode of "METER/M&A".
3. Turn the ignition switch OFF and wait for 10 seconds or more.
4. Turn the ignition switch ON.
5. Select "Self Diagnostic Result" mode of "METER/M&A".

Is DTC detected?

YES >> Check the DTC. Refer to [MWI-29, "DTC Index"](#).

NO >> GO TO 5.

## 5. PERFORM SELF-DIAGNOSIS

ⓂCONSULT

1. Connect chassis control module harness connector.
2. Erase "Self Diagnostic Result" mode of "CHASSIS CONTROL".
3. Turn the ignition switch OFF and wait for 10 seconds or more.
4. Turn the ignition switch ON.
5. Select "All DTC Reading" mode.

Is DTC "U1000-00", "U1A39-00" or other DTC detected?

YES ("U1000-00")>> Refer to [DAS-264, "Diagnosis Procedure"](#).

YES ("U1A39-00")>> Replace the chassis control module. Refer to [DAS-290, "Removal and Installation"](#).

YES (other DTC)>> Check the DTC.

NO >> Inspection End.

# U1A3B-00 TCM COMMUNICATION

< DTC/CIRCUIT DIAGNOSIS >

[CHASSIS CONTROL]

## U1A3B-00 TCM COMMUNICATION

### DTC Description

INFOID:000000012271764

### DTC DETECTION LOGIC

DTC No.	CONSULT screen terms (Trouble diagnosis content)	DTC detection condition	
U1A3B-00	TCM COMM (TCM communication)	Diagnosis condition	When ignition switch is ON.
		Signal (terminal)	–
		Threshold	When chassis control module is not receiving CAN communication signal (between chassis control module and TCM)
		Diagnosis delay time	2 seconds or more

### POSSIBLE CAUSE

- TCM
- Chassis control module
- CAN communication line

### FAIL-SAFE

The following functions are suspended:

- Active Trace Control function
- Active Ride Control (engine) function
- Active Engine Brake

### DTC CONFIRMATION PROCEDURE

#### 1. PRECONDITIONING

If “DTC CONFIRMATION PROCEDURE” has been previously conducted, always turn the ignition switch OFF and wait at least 10 seconds before conducting the next test.

>> GO TO 2.

#### 2. CHECK DTC DETECTION

##### CONSULT

1. Turn the ignition switch OFF to ON.

##### CAUTION:

**Be sure to wait 10 seconds after turning ignition switch OFF or ON.**

2. Select “Self Diagnostic Result” mode of “CHASSIS CONTROL”.

Is DTC “U1A3B-00” detected?

YES >> Proceed to [DAS-273. "Diagnosis Procedure"](#).

NO-1 >> To check malfunction symptom before repair: Refer to [GI-41. "Intermittent Incident"](#).

NO-2 >> Confirmation after repair: Inspection End.

### Diagnosis Procedure

INFOID:000000012271765

Regarding Wiring Diagram information, refer to [DAS-212. "Wiring Diagram"](#).

#### 1. CHECK CAN DIAGNOSIS SUPPORT MONITOR

##### CONSULT

1. Select “CAN Diagnosis Support Monitor” mode of “CHASSIS CONTROL”.
2. Check for malfunction between each control unit connected to chassis control module.

Check the result of “PRESENT”?

>> Refer to [LAN-9. "CAN Communication Control Circuit"](#).

A  
B  
C  
D  
E  
F  
G  
H  
I  
J  
K  
L  
M  
N  
P

# U1A3B-00 TCM COMMUNICATION

[CHASSIS CONTROL]

< DTC/CIRCUIT DIAGNOSIS >

"TRANSMIT DIAG" is other than "OK">> GO TO 2.

"TRANSMISSION" other than "OK">> GO TO 3.

## 2.CHECK TRANSMITTING SIDE UNIT

1. Turn the ignition switch OFF.
2. Disconnect chassis control module harness connector.
3. Check the chassis control module harness connector terminals 3 and 4 for damage or loose connection.

Is the inspection result normal?

YES >> GO TO 5.

NO >> Recheck terminals for damage or loose connection. Refer to [LAN-7, "Precautions for Harness Repair"](#). GO TO 5.

## 3.CHECK TCM

1. Turn the ignition switch OFF.
2. Disconnect TCM harness connector.
3. Check TCM harness connector terminals (CAN communication line) for damage or loose connection.

Is the inspection result normal?

YES >> GO TO 4.

NO >> Recheck terminals for damage or loose connection. Refer to [LAN-7, "Precautions for Harness Repair"](#). GO TO 4.

## 4.PERFORM SELF-DIAGNOSIS (TCM)

ⓅCONSULT

1. Connect TCM harness connector.
2. Erase "Self Diagnostic Result" mode of "TRANSMISSION".
3. Turn the ignition switch OFF and wait for 10 seconds or more.
4. Turn the ignition switch ON.
5. Select "Self Diagnostic Result" mode of "TRANSMISSION".

Is DTC detected?

YES >> Check the DTC. Refer to [TM-58, "DTC Index"](#).

NO >> GO TO 5.

## 5.PERFORM SELF-DIAGNOSIS

ⓅCONSULT

1. Connect chassis control module harness connector.
2. Erase "Self Diagnostic Result" mode of "CHASSIS CONTROL".
3. Turn the ignition switch OFF and wait for 10 seconds or more.
4. Turn the ignition switch ON.
5. Select "All DTC Reading" mode.

Is DTC "U1000-00", "U1A3B-00" or other DTC detected?

YES ("U1000-00")>> Refer to [DAS-264, "Diagnosis Procedure"](#).

YES ("U1A3B-00")>> Replace the chassis control module. Refer to [DAS-290, "Removal and Installation"](#).

YES (other DTC)>> Check the DTC.

NO >> Inspection End.

# U1A42-00 STEERING ANGLE SENSOR COMMUNICATION

< DTC/CIRCUIT DIAGNOSIS >

[CHASSIS CONTROL]

## U1A42-00 STEERING ANGLE SENSOR COMMUNICATION

### DTC Description

INFOID:0000000012271766

### DTC DETECTION LOGIC

DTC No.	CONSULT screen terms (Trouble diagnosis content)	DTC detection condition	
U1A42-00	STEERING ANGLE SENSOR COMM (Steering angle sensor communi- cation)	Diagnosis condition	When ignition switch is ON.
		Signal (terminal)	–
		Threshold	When chassis control module is not receiv- ing CAN communication signal (between chassis control module and steering angle sensor)
		Diagnosis delay time	2 seconds or more

### POSSIBLE CAUSE

- Steering angle sensor
- Chassis control module
- CAN communication line

### FAIL-SAFE

The following functions are suspended:

- Active Trace Control function
- Active Ride Control (engine) function

### DTC CONFIRMATION PROCEDURE

#### 1. PRECONDITIONING

If “DTC CONFIRMATION PROCEDURE” has been previously conducted, always turn the ignition switch OFF and wait at least 10 seconds before conducting the next test.

>> GO TO 2.

#### 2. CHECK DTC DETECTION

##### CONSULT

1. Turn the ignition switch OFF to ON.

##### CAUTION:

**Be sure to wait 10 seconds after turning ignition switch OFF or ON.**

2. Select “Self Diagnostic Result” mode of “CHASSIS CONTROL”.

##### Is DTC “U1A42-00” detected?

- YES >> Proceed to [DAS-275, "Diagnosis Procedure"](#).
- NO-1 >> To check malfunction symptom before repair: Refer to [GI-41, "Intermittent Incident"](#).
- NO-2 >> Confirmation after repair: Inspection End.

### Diagnosis Procedure

INFOID:0000000012271767

Regarding Wiring Diagram information, refer to [DAS-212, "Wiring Diagram"](#).

#### 1. CHECK CAN DIAGNOSIS SUPPORT MONITOR

##### CONSULT

1. Select “CAN Diagnosis Support Monitor” mode of “CHASSIS CONTROL”.
2. Check for malfunction between each control unit connected to chassis control module.

##### Check the result of “PRESENT”?

>> Refer to [LAN-9, "CAN Communication Control Circuit"](#).

A  
B  
C  
D  
E  
F  
G  
H  
I  
J  
K  
L  
M  
N  
P



# U1A42-00 STEERING ANGLE SENSOR COMMUNICATION

< DTC/CIRCUIT DIAGNOSIS >

[CHASSIS CONTROL]

“TRANSMIT DIAG” is other than “OK”>> GO TO 2.

“STRG” other than “OK”>> GO TO 3.

## 2.CHECK TRANSMITTING SIDE UNIT

1. Turn the ignition switch OFF.
2. Disconnect chassis control module harness connector.
3. Check the chassis control module harness connector terminals 3 and 4 for damage or loose connection.

Is the inspection result normal?

YES >> GO TO 5.

NO >> Recheck terminals for damage or loose connection. Refer to [LAN-7, "Precautions for Harness Repair"](#). GO TO 5.

## 3.CHECK STEERING ANGLE SENSOR

1. Turn the ignition switch OFF.
2. Disconnect steering angle sensor harness connector.
3. Check steering angle sensor harness connector terminals (CAN communication line) or damage or loose connection.

Is the inspection result normal?

YES >> GO TO 4.

NO >> Recheck terminals for damage or loose connection. Refer to [LAN-7, "Precautions for Harness Repair"](#). GO TO 4.

## 4.PERFORM SELF-DIAGNOSIS [ABS ACTUATOR AND ELECTRIC UNIT (CONTROL UNIT)]

ⓅCONSULT

1. Connect steering angle sensor harness connector.
2. Erase “Self Diagnostic Result” mode of “ABS”.
3. Turn the ignition switch OFF and wait for 10 seconds or more.
4. Turn the ignition switch ON.
5. Select “Self Diagnostic Result” mode of “ABS”.

Is DTC detected?

YES >> Check the DTC. Refer to [BRC-227, "DTC Index"](#).

NO >> GO TO 5.

## 5.PERFORM SELF-DIAGNOSIS

ⓅCONSULT

1. Connect chassis control module harness connector.
2. Erase “Self Diagnostic Result” mode of “CHASSIS CONTROL”.
3. Turn the ignition switch OFF and wait for 10 seconds or more.
4. Turn the ignition switch ON.
5. Select “All DTC Reading” mode.

Is DTC “U1000-00”, “U1A42-00” other DTC detected?

YES (“U1000-00”)>> Refer to [DAS-264, "Diagnosis Procedure"](#).

YES (“U1A42-00”)>> Replace the chassis control module. Refer to [DAS-290, "Removal and Installation"](#).

YES (other DTC)>> Check the DTC.

NO >> Inspection End.



# U1A43-00 STEERING ANGLE SENSOR COMMUNICATION

< DTC/CIRCUIT DIAGNOSIS >

[CHASSIS CONTROL]

## U1A43-00 STEERING ANGLE SENSOR COMMUNICATION

### DTC Description

INFOID:000000012271768

### DTC DETECTION LOGIC

DTC No.	CONSULT screen terms (Trouble diagnosis content)	DTC detection condition	
U1A43-00	STEERING ANGLE SENSOR COMM (Steering angle sensor communi- cation)	Diagnosis condition	When ignition switch is ON.
		Signal (terminal)	–
		Threshold	A calculated signal value differs between a signal transmitted from the steering angle sensor and a signal received from chassis control module via CAN communication
		Diagnosis delay time	–

### POSSIBLE CAUSE

- Steering angle sensor
- Chassis control module
- CAN communication line

### FAIL-SAFE

The following functions are suspended:

- Active Trace Control function
- Active Ride Control (engine) function

### DTC CONFIRMATION PROCEDURE

#### 1. PRECONDITIONING

If “DTC CONFIRMATION PROCEDURE” has been previously conducted, always turn the ignition switch OFF and wait at least 10 seconds before conducting the next test.

>> GO TO 2.

#### 2. CHECK DTC DETECTION

##### CONSULT

1. Turn the ignition switch OFF to ON.

##### CAUTION:

**Be sure to wait 10 seconds after turning ignition switch OFF or ON.**

2. Select “Self Diagnostic Result” mode of “CHASSIS CONTROL”.

Is DTC “U1A43-00” detected?

- YES >> Proceed to [DAS-277, "Diagnosis Procedure"](#).
- NO-1 >> To check malfunction symptom before repair: Refer to [GI-41, "Intermittent Incident"](#).
- NO-2 >> Confirmation after repair: Inspection End.

### Diagnosis Procedure

INFOID:000000012271769

Regarding Wiring Diagram information, refer to [DAS-212, "Wiring Diagram"](#).

#### 1. CHECK CAN DIAGNOSIS SUPPORT MONITOR

##### CONSULT

1. Select “CAN Diagnosis Support Monitor” mode of “CHASSIS CONTROL”.
2. Check for malfunction between each control unit connected to chassis control module.

Check the result of “PRESENT”?

>> Refer to [LAN-9, "CAN Communication Control Circuit"](#).

# U1A43-00 STEERING ANGLE SENSOR COMMUNICATION

< DTC/CIRCUIT DIAGNOSIS >

[CHASSIS CONTROL]

“TRANSMIT DIAG” is other than “OK”>> GO TO 2.

“STRG” other than “OK”>> GO TO 3.

## 2.CHECK TRANSMITTING SIDE UNIT

1. Turn the ignition switch OFF.
2. Disconnect chassis control module harness connector.
3. Check the chassis control module harness connector terminals 3 and 4 for damage or loose connection.

Is the inspection result normal?

YES >> GO TO 5.

NO >> Recheck terminals for damage or loose connection. Refer to [LAN-7, "Precautions for Harness Repair"](#). GO TO 5.

## 3.CHECK STEERING ANGLE SENSOR

1. Turn the ignition switch OFF.
2. Disconnect steering angle sensor harness connector.
3. Check steering angle sensor harness connector terminals (CAN communication line) for damage or loose connection.

Is the inspection result normal?

YES >> GO TO 4.

NO >> Recheck terminals for damage or loose connection. Refer to [LAN-7, "Precautions for Harness Repair"](#). GO TO 4.

## 4.PERFORM SELF-DIAGNOSIS [ABS ACTUATOR AND ELECTRIC UNIT (CONTROL UNIT)]

ⓅCONSULT

1. Connect steering angle sensor harness connector.
2. Erase “Self Diagnostic Result” mode of “ABS”.
3. Turn the ignition switch OFF and wait for 10 seconds or more.
4. Turn the ignition switch ON.
5. Select “Self Diagnostic Result” mode of “ABS”.

Is DTC detected?

YES >> Check the DTC. Refer to [BRC-227, "DTC Index"](#).

NO >> GO TO 5.

## 5.PERFORM SELF-DIAGNOSIS

ⓅCONSULT

1. Connect chassis control module harness connector.
2. Erase “Self Diagnostic Result” mode of “CHASSIS CONTROL”.
3. Turn the ignition switch OFF and wait for 10 seconds or more.
4. Turn the ignition switch ON.
5. Select “All DTC Reading” mode.

Is DTC “U1000-00”, “U1A43-00” or other DTC detected?

YES (“U1000-00”)>> Refer to [DAS-264, "Diagnosis Procedure"](#).

YES (“U1A43-00”)>> Replace the chassis control module. Refer to [DAS-290, "Removal and Installation"](#).

YES (other DTC)>> Check the DTC.

NO >> Inspection End.

# U1A48-00 ECM COMMUNICATION

< DTC/CIRCUIT DIAGNOSIS >

[CHASSIS CONTROL]

## U1A48-00 ECM COMMUNICATION

### DTC Description

INFOID:000000012271770

### DTC DETECTION LOGIC

DTC No.	CONSULT screen terms (Trouble diagnosis content)	DTC detection condition	
		Diagnosis condition	When ignition switch is ON.
U1A48-00	ECM COMM (ECM communication)	Signal (terminal)	–
		Threshold	When chassis control module is not receiving CAN communication signal (between chassis control module and ECM)
		Diagnosis delay time	2 seconds or more

### POSSIBLE CAUSE

- ECM
- Chassis control module
- CAN communication line

### FAIL-SAFE

The following functions are suspended:

- Active Trace Control function
- Active Ride Control function
- Active Engine Brake function

### DTC CONFIRMATION PROCEDURE

#### 1. PRECONDITIONING

If "DTC CONFIRMATION PROCEDURE" has been previously conducted, always turn the ignition switch OFF and wait at least 10 seconds before conducting the next test.

>> GO TO 2.

#### 2. CHECK DTC DETECTION

##### CONSULT

1. Turn the ignition switch OFF to ON.

##### CAUTION:

**Be sure to wait 10 seconds after turning ignition switch OFF or ON.**

2. Select "Self Diagnostic Result" mode of "CHASSIS CONTROL".

Is DTC "U1A48-00" detected?

YES >> Proceed to [DAS-279, "Diagnosis Procedure"](#).

NO-1 >> To check malfunction symptom before repair: Refer to [GI-41, "Intermittent Incident"](#).

NO-2 >> Confirmation after repair: Inspection End.

### Diagnosis Procedure

INFOID:000000012271771

Regarding Wiring Diagram information, refer to [DAS-212, "Wiring Diagram"](#).

#### 1. CHECK CAN DIAGNOSIS SUPPORT MONITOR

##### CONSULT

1. Select "CAN Diagnosis Support Monitor" mode of "CHASSIS CONTROL".
2. Check for malfunction between each control unit connected to chassis control module.

Check the result of "PRESENT"?

>> Refer to [LAN-9, "CAN Communication Control Circuit"](#).

A  
B  
C  
D  
E  
F  
G  
H  
I  
J  
K  
L  
M  
N  
P

# U1A48-00 ECM COMMUNICATION

[CHASSIS CONTROL]

< DTC/CIRCUIT DIAGNOSIS >

"TRANSMIT DIAG" is other than "OK">> GO TO 2.

"ENGINE" other than "OK">> GO TO 3.

## 2.CHECK TRANSMITTING SIDE UNIT

1. Turn the ignition switch OFF.
2. Disconnect chassis control module harness connector.
3. Check the chassis control module harness connector terminals 3 and 4 for damage or loose connection.

Is the inspection result normal?

YES >> GO TO 5.

NO >> Recheck terminals for damage or loose connection. Refer to [LAN-7, "Precautions for Harness Repair"](#). GO TO 5.

## 3.CHECK ECM

1. Turn the ignition switch OFF.
2. Disconnect ECM harness connector.
3. Check ECM harness connector terminals (CAN communication line) for damage or loose connection.

Is the inspection result normal?

YES >> GO TO 4.

NO >> Recheck terminals for damage or loose connection. Refer to [LAN-7, "Precautions for Harness Repair"](#). GO TO 4.

## 4.PERFORM SELF-DIAGNOSIS (ECM)

ⓅCONSULT

1. Connect ECM harness connector.
2. Erase "Self Diagnostic Result" mode of "ENGINE".
3. Turn the ignition switch OFF and wait for 10 seconds or more.
4. Turn the ignition switch ON.
5. Select "Self Diagnostic Result" mode of "ENGINE".

Is DTC detected?

YES >> Check the DTC. Refer to [EC-107, "DTC Index"](#).

NO >> GO TO 5.

## 5.PERFORM SELF-DIAGNOSIS

ⓅCONSULT

1. Connect chassis control module harness connector.
2. Erase "Self Diagnostic Result" mode of "CHASSIS CONTROL".
3. Turn the ignition switch OFF and wait for 10 seconds or more.
4. Turn the ignition switch ON.
5. Select "All DTC Reading" mode.

Is DTC "U1000-00", "U1A48-00" or other DTC detected?

YES ("U1000-00")>> Refer to [DAS-264, "Diagnosis Procedure"](#).

YES ("U1A48-00")>> Replace the chassis control module. Refer to [DAS-290, "Removal and Installation"](#).

YES (other DTC)>> Check the DTC.

NO >> Inspection End.

# U1A4A-00 CONTROL MODULE (CAN)

< DTC/CIRCUIT DIAGNOSIS >

[CHASSIS CONTROL]

## U1A4A-00 CONTROL MODULE (CAN)

### DTC Description

INFOID:000000012271772

### DTC DETECTION LOGIC

DTC No.	CONSULT screen terms (Trouble diagnosis content)	DTC detection condition	
U1A4A-00	CONTROL MODULE (CAN) [Control module (CAN)]	Diagnosis condition	When ignition switch is ON.
		Signal (terminal)	–
		Threshold	When a malfunction is detected in chassis control module (Transmission via CAN communication is impossible)
		Diagnosis delay time	–

### POSSIBLE CAUSE

Chassis control module

### FAIL-SAFE

The following functions are suspended:

- Active Trace Control function
- Active Ride Control function
- Active Engine Brake function

### DTC CONFIRMATION PROCEDURE

#### 1. PRECONDITIONING

If "DTC CONFIRMATION PROCEDURE" has been previously conducted, always turn the ignition switch OFF and wait at least 10 seconds before conducting the next test.

>> GO TO 2.

#### 2. CHECK DTC DETECTION

##### CONSULT

1. Turn the ignition switch OFF to ON.

##### CAUTION:

**Be sure to wait 10 seconds after turning ignition switch OFF or ON.**

2. Select "Self Diagnostic Result" mode of "CHASSIS CONTROL".

##### Is DTC "U1A4A-00" detected?

YES >> Proceed to [DAS-281, "Diagnosis Procedure"](#).

NO-1 >> To check malfunction symptom before repair: Refer to [GI-41, "Intermittent Incident"](#).

NO-2 >> Confirmation after repair: Inspection End.

### Diagnosis Procedure

INFOID:000000012271773

#### 1. PERFORM SELF-DIAGNOSIS

##### CONSULT

1. Erase "Self Diagnostic Result" mode of "CHASSIS CONTROL".
2. Turn the ignition switch OFF and wait for 10 seconds or more.
3. Turn the ignition switch ON.
4. Select "Self Diagnostic Result" mode of "CHASSIS CONTROL".

##### Is DTC "U1A4A-00" detected?

YES >> Replace the chassis control module. Refer to [DAS-290, "Removal and Installation"](#).

NO >> Inspection End.

A  
B  
C  
D  
E  
F  
G  
H  
I  
J  
K  
L  
M  
N  
P

DAS

# U1A4B-00 CONTROL MODULE (CAN)

< DTC/CIRCUIT DIAGNOSIS >

[CHASSIS CONTROL]

## U1A4B-00 CONTROL MODULE (CAN)

### DTC Description

INFOID:000000012271774

### DTC DETECTION LOGIC

DTC No.	CONSULT screen terms (Trouble diagnosis content)	DTC detection condition	
U1A4B-00	CONTROL MODULE (CAN) [Control module (CAN)]	Diagnosis condition	When ignition switch is ON.
		Signal (terminal)	–
		Threshold	When a malfunction is detected in chassis control module
		Diagnosis delay time	–

### POSSIBLE CAUSE

Chassis control module

### FAIL-SAFE

The following functions are suspended:

- Active Trace Control function
- Active Ride Control function
- Active Engine Brake function

### DTC CONFIRMATION PROCEDURE

#### 1. PRECONDITIONING

If “DTC CONFIRMATION PROCEDURE” has been previously conducted, always turn the ignition switch OFF and wait at least 10 seconds before conducting the next test.

>> GO TO 2.

#### 2. CHECK DTC DETECTION

##### CONSULT

1. Turn the ignition switch OFF to ON.

##### CAUTION:

**Be sure to wait 10 seconds after turning ignition switch OFF or ON.**

2. Select “Self Diagnostic Result” mode of “CHASSIS CONTROL”.

##### Is DTC “U1A4B-00” detected?

YES >> Proceed to [DAS-282, "Diagnosis Procedure"](#).

NO-1 >> To check malfunction symptom before repair: Refer to [GI-41, "Intermittent Incident"](#).

NO-2 >> Confirmation after repair: Inspection End.

### Diagnosis Procedure

INFOID:000000012271775

#### 1. PERFORM SELF-DIAGNOSIS

##### CONSULT

1. Erase “Self Diagnostic Result” mode of “CHASSIS CONTROL”.
2. Turn the ignition switch OFF and wait for 10 seconds or more.
3. Turn the ignition switch ON.
4. Select “Self Diagnostic Result” mode of “CHASSIS CONTROL”.

##### Is DTC “U1A4B-00” detected?

YES >> Replace the chassis control module. Refer to [DAS-290, "Removal and Installation"](#).

NO >> Inspection End.

# U1A4E-00 ECM COMMUNICATION

< DTC/CIRCUIT DIAGNOSIS >

[CHASSIS CONTROL]

## U1A4E-00 ECM COMMUNICATION

### DTC Description

INFOID:000000012271776

### DTC DETECTION LOGIC

DTC No.	CONSULT screen terms (Trouble diagnosis content)	DTC detection condition	
U1A4E-00	ECM COMM (ECM communication)	Diagnosis condition	When ignition switch is ON.
		Signal (terminal)	–
		Threshold	A calculated signal value differs between a signal transmitted from the ECM and a signal received from chassis control module via CAN communication
		Diagnosis delay time	–

### POSSIBLE CAUSE

- ECM
- Chassis control module
- CAN communication line

### FAIL-SAFE

The following function is suspended:

- Active Ride Control (engine) function

### DTC CONFIRMATION PROCEDURE

#### 1. PRECONDITIONING

If “DTC CONFIRMATION PROCEDURE” has been previously conducted, always turn the ignition switch OFF and wait at least 10 seconds before conducting the next test.

>> GO TO 2.

#### 2. CHECK DTC DETECTION

##### CONSULT

1. Turn the ignition switch OFF to ON.

##### CAUTION:

**Be sure to wait 10 seconds after turning ignition switch OFF or ON.**

2. Select “Self Diagnostic Result” mode of “CHASSIS CONTROL”.

##### Is DTC “U1A4E-00” detected?

YES >> Proceed to [DAS-283, "Diagnosis Procedure"](#).

NO-1 >> To check malfunction symptom before repair: Refer to [GI-41, "Intermittent Incident"](#).

NO-2 >> Confirmation after repair: Inspection End.

### Diagnosis Procedure

INFOID:000000012271777

Regarding Wiring Diagram information, refer to [DAS-212, "Wiring Diagram"](#).

#### 1. CHECK CAN DIAGNOSIS SUPPORT MONITOR

##### CONSULT

1. Select “CAN Diagnosis Support Monitor” mode of “CHASSIS CONTROL”.
2. Check for malfunction history between each control unit connected to chassis control module.

##### Check the result of “PAST”?

All items are “OK”>>Refer to [GI-41, "Intermittent Incident"](#).

“TRANSMIT DIAG” is other than “OK”>> GO TO 2.

A  
B  
C  
D  
E  
F  
G  
H  
I  
J  
K  
L  
M  
N  
P

# U1A4E-00 ECM COMMUNICATION

[CHASSIS CONTROL]

< DTC/CIRCUIT DIAGNOSIS >

"ENGINE" other than "OK">> GO TO 3.

## 2.CHECK TRANSMITTING SIDE UNIT

1. Turn the ignition switch OFF.
2. Disconnect chassis control module harness connector.
3. Check the chassis control module harness connector terminals 3 and 4 for damage or loose connection.

Is the inspection result normal?

YES >> GO TO 5.

NO >> Recheck terminals for damage or loose connection. Refer to [LAN-7, "Precautions for Harness Repair"](#). GO TO 5.

## 3.CHECK ECM

1. Turn the ignition switch OFF.
2. Disconnect ECM harness connector.
3. Check ECM harness connector terminals (CAN communication line) for damage or loose connection.

Is the inspection result normal?

YES >> GO TO 4.

NO >> Recheck terminals for damage or loose connection. Refer to [LAN-7, "Precautions for Harness Repair"](#). GO TO 4.

## 4.PERFORM SELF-DIAGNOSIS (ECM)

ⓅCONSULT

1. Connect ECM harness connector.
2. Erase "Self Diagnostic Result" mode of "ENGINE".
3. Turn the ignition switch OFF and wait for 10 seconds or more.
4. Turn the ignition switch ON.
5. Select "Self Diagnostic Result" mode of "ENGINE".

Is DTC detected?

YES >> Check the DTC. Refer to [EC-107, "DTC Index"](#).

NO >> GO TO 5.

## 5.PERFORM SELF-DIAGNOSIS

ⓅCONSULT

1. Connect chassis control module harness connector.
2. Erase "Self Diagnostic Result" mode of "CHASSIS CONTROL".
3. Turn the ignition switch OFF and wait for 10 seconds or more.
4. Turn the ignition switch ON.
5. Select "All DTC Reading" mode.

Is DTC "U1000-00", "U1A4E-00" or other DTC detected?

YES ("U1000-00")>> Refer to [DAS-264, "Diagnosis Procedure"](#).

YES ("U1A4E-00")>> Replace the chassis control module. Refer to [DAS-290, "Removal and Installation"](#).

YES (other DTC)>> Check the DTC.

NO >> Inspection End.



# POWER SUPPLY AND GROUND CIRCUIT

< DTC/CIRCUIT DIAGNOSIS >

[CHASSIS CONTROL]

## POWER SUPPLY AND GROUND CIRCUIT

### Diagnosis Procedure

INFOID:000000012271778

Regarding Wiring Diagram information, refer to [DAS-212. "Wiring Diagram"](#).

### 1.CHECK FUSE

Check that the following fuse is not blown.

Terminal	Signal name	Fuse No.
7P	Ignition power supply	30 (10 A)

Is the fuse blown?

- YES >> Replace the blown fuse after repairing the affected circuit.  
NO >> GO TO 2.

### 2.CHECK POWER SUPPLY CIRCUIT

1. Turn the ignition switch OFF.
2. Disconnect chassis control module harness connector M181.
3. Check the voltage between chassis control module harness connector M181 terminal 10 and ground.

Chassis control module		—	Voltage (Approx.)
Connector	Terminal		
M181	10	Ground	0 V

4. Turn the ignition switch ON.  
**CAUTION:**  
**Never start the engine.**
5. Check the voltage between chassis control module harness connector M181 terminal 10 and ground.

Chassis control module		—	Voltage (Approx.)
Connector	Terminal		
M181	10	Ground	6.4–16 V

Is the inspection result normal?

- YES >> GO TO 3.  
NO >> Repair or replace harness or connector.

### 3.CHECK CHASSIS CONTROL MODULE GROUND CIRCUIT

Check the continuity between chassis control module harness connector M181 terminal 12 and ground.

Chassis control module		—	Continuity
Connector	Terminal		
M181	12	Ground	Yes

Is the inspection result normal?

- YES >> Inspection End.  
NO >> Repair or replace harness or connector.

A  
B  
C  
D  
E  
F  
G  
H  
I  
J  
K  
L  
M  
N  
P

DAS

## SYMPTOM DIAGNOSIS

### CHASSIS CONTROL

#### Active Engine Brake

INFOID:000000012271779

**NOTE:**

- For the operational conditions of Active Engine Brake, refer to [DAS-192, "ACTIVE ENGINE BRAKE FUNCTION : System Description"](#).
- Perform the "Self Diagnostic Result" using CONSULT before the symptom diagnosis. Perform the trouble diagnosis if any DTC is detected.

Symptom		Possible cause	Inspection item	
Active Engine Brake inoperative/ineffective	No CVT gear ratio assist	Active Engine Brake is selected OFF in the vehicle information display.	Change Active Engine Brake selection in the vehicle information display to ON.	
		Certain roads, inclement weather or driving conditions	System is functioning normally. Confirm the condition with the customer. Refer to <a href="#">DAS-200, "Precautions for Chassis Control (Engine Brake, Active Ride, and Active Trace)"</a> .	
		<ul style="list-style-type: none"> <li>• Road wheel tire condition is abnormal.</li> <li>• Road wheel tire size is abnormal.</li> </ul>	Check the road wheel tire.	
	Lower CVT gear ratio is not achieved.	Continuously	Active Engine Brake is selected OFF in the vehicle information display.	Change Active Engine Brake selection in the vehicle information display to ON.
		At cornering	<ul style="list-style-type: none"> <li>• Wheel alignment</li> <li>• Steering malfunction</li> </ul>	Refer to "STEERING WHEEL TURNING FORCE IS HEAVY OR LIGHT" <a href="#">STC-34, "Diagnosis Procedure"</a> .
		While coming to a complete stop	Certain roads, inclement weather or driving conditions	System is functioning normally. Confirm the condition with the customer. Refer to <a href="#">DAS-200, "Precautions for Chassis Control (Engine Brake, Active Ride, and Active Trace)"</a> .

#### Active Ride Control

INFOID:000000012271780

**NOTE:**

- For the operational conditions of Active Ride Control, refer to [DAS-195, "ACTIVE RIDE CONTROL FUNCTION : System Description"](#).
- Perform the "Self Diagnostic Result" using CONSULT before the symptom diagnosis. Perform the trouble diagnosis if any DTC is detected.

# CHASSIS CONTROL

< SYMPTOM DIAGNOSIS >

[CHASSIS CONTROL]

Symptom		Possible cause	Inspection item	
Active Ride Control in-operative/ineffective	No Active Ride Control assist	VDC OFF switch is engaged.	Turn VDC OFF switch to the OFF position.	
		Engine or transmission DTCs are present.	Refer to EC DTCs <a href="#">EC-107</a> , " <a href="#">DTC Index</a> " or TM DTCs <a href="#">TM-58</a> , " <a href="#">DTC Index</a> " as necessary.	
	Bumpy ride on bumpy road	Certain roads, inclement weather or driving conditions	System is functioning normally. Confirm the condition with the customer. Refer to <a href="#">DAS-200</a> , " <a href="#">Precautions for Chassis Control (Engine Brake, Active Ride, and Active Trace)</a> ".	
		<ul style="list-style-type: none"> <li>Road wheel tire condition is abnormal.</li> <li>Road wheel tire size is abnormal.</li> </ul>	Check the road wheel tire.	
	High vehicle pitch on bumps	Ineffective pitch control	<ul style="list-style-type: none"> <li>Wheel alignment</li> <li>Steering malfunction</li> </ul>	Change Active Engine Brake selection in the vehicle information display to ON.
		No pitch control	Brake system malfunction	Refer to <a href="#">BRC-226</a> , " <a href="#">DTC Inspection Priority Chart</a> ".
		No engine torque control on curves	Certain roads, inclement weather or driving conditions	System is functioning normally. Confirm the condition with the customer. Refer to <a href="#">DAS-200</a> , " <a href="#">Precautions for Chassis Control (Engine Brake, Active Ride, and Active Trace)</a> ".

## Active Trace Control

INFOID:000000012271781

### NOTE:

- For the operational conditions of Active Trace Control, refer to [DAS-186](#), "[ACTIVE TRACE CONTROL \(DYNAMIC CORNERING ENHANCEMENT\) FUNCTION : System Description](#)".
- Perform the "Self Diagnostic Result" using CONSULT before the symptom diagnosis. Perform the trouble diagnosis if any DTC is detected.

DAS

# CHASSIS CONTROL

< SYMPTOM DIAGNOSIS >

[CHASSIS CONTROL]

Symptom		Possible cause	Inspection item	
Active Trace Control inoperative/ineffective	No Active Trace Control assist	Active Trace Control is selected OFF in the vehicle information display.	Change Active Trace Control selection in the vehicle information display to ON.	
		VDC OFF switch is engaged.	Turn VDC OFF switch to the OFF position.	
		Certain roads, inclement weather or driving conditions	System is functioning normally. Confirm the condition with the customer. Refer to <a href="#">DAS-200, "Precautions for Chassis Control (Engine Brake, Active Ride, and Active Trace)"</a> .	
		<ul style="list-style-type: none"> <li>• Road wheel tire condition is abnormal.</li> <li>• Road wheel tire size is abnormal.</li> </ul>	Check the road wheel tire.	
	Excessive lag on turns	On turns	Wheel alignment	Repair alignment malfunction.
		While zigzagging	Steering malfunction	"STEERING WHEEL TURNING FORCE IS HEAVY OR LIGHT" Refer to <a href="#">STC-34, "Diagnosis Procedure"</a> .
		With quick lane change	Certain roads, inclement weather or driving conditions	System is functioning normally. Confirm the condition with the customer. Refer to <a href="#">DAS-200, "Precautions for Chassis Control (Engine Brake, Active Ride, and Active Trace)"</a> .

# NORMAL OPERATING CONDITION

< SYMPTOM DIAGNOSIS >

[CHASSIS CONTROL]

## NORMAL OPERATING CONDITION

### Description

INFOID:000000012271782

#### CHASSIS CONTROL

- Chassis Control will not provide all the necessary controls to replace driver intervention. It is not designed to prevent loss of control. It is the driver's responsibility to stay alert, drive safely, keep the vehicle in the traveling lane, and be in control of vehicle at all times.
- Chassis Control is primarily intended for use on well-developed freeways or highways. It may not perform satisfactorily in certain road, weather or driving conditions.
- Using Chassis Control under some road, corner or severe weather conditions could lead to an unexpected system operation. In such conditions, driver needs to correct the vehicle's direction with steering operation to avoid accidents.
- When Chassis Control is operating, avoid excessive or sudden steering maneuvers. Otherwise, you could lose control of the vehicle.
- Engine Brake Control is designed to enhance braking feel and traceability at corners.
- Active Ride Control is designed to enhance handling and drive comfort.
- Active Trace Control is designed to enhance traceability at corners and smooth vehicle movement for more confident driving.
- Chassis Control may not function properly under the following conditions:
  - During bad weather (rain, fog, snow, wind, etc.).
  - When driving on slippery roads, such as on ice or snow, etc.
  - When driving on winding or uneven roads.
  - When driving with a tire that is not within normal tire conditions (for example, tire wear, low tire pressure, installation of spare tire, tire chains or non-standard wheels).
  - When the vehicle is equipped with non-original steering parts or suspension parts.
- The functions of Chassis Control may or may not operate properly under the following conditions:
  - On roads covered with water, dirt or snow, etc.
  - On roads where there are sharp curves.

A  
B  
C  
D  
E  
F  
G  
H  
I  
J  
K  
L  
M  
N  
P

DAS

## REMOVAL AND INSTALLATION

### CHASSIS CONTROL MODULE

Exploded View

INFOID:000000012271783

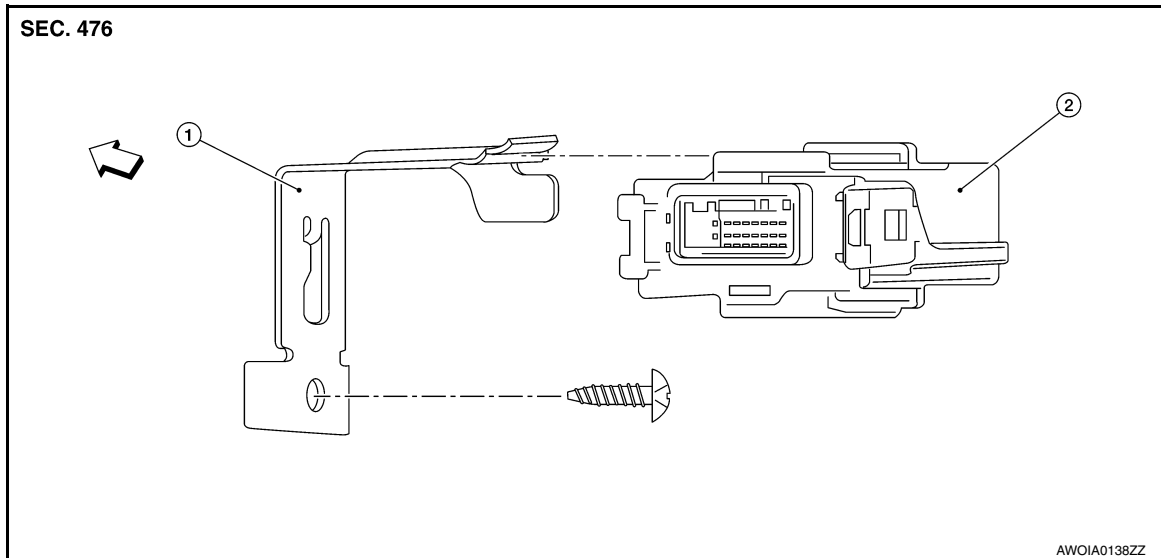

1. Bracket

2. Chassis control module

← Front

### Removal and Installation

INFOID:000000012271784

#### REMOVAL

##### NOTE:

If chassis control module is replaced, user registration information is erased and all setting items for NISSAN InTuition related parts are erased.

1. Remove glove box assembly. Refer to [IP-24. "Removal and Installation"](#).
2. Remove screw from chassis control module bracket.
3. Disconnect harness connector from chassis control module and remove chassis control module.

##### CAUTION:

**Do not drop chassis control module.**

#### INSTALLATION

Installation is in the reverse order of removal.

##### CAUTION:

**When replacing chassis control module, perform the configuration of chassis control module. Refer to [DAS-217. "Description"](#).**